

A FAMILY OF TWENTY-AMPERES POWER SUPPLIES FOR MULTI-POLE CORRECTORS FOR ACCELERATORS AND STORAGE RINGS

O. Belikov, V. Kozak, A. Medvedko, BINP, Novosibirsk, Russia

Abstract

For decades, we at Budker Institute of Nuclear Physics SB RAS have developed precision power supplies for the electromagnets of accelerator facilities and storage ring complexes in broad range of output power. Some tasks, e.g. powering correctors, multipole magnets and low-current bending magnets, operate with up to 20A regulated current sources with an output power of about a few kilowatts [1]. Our long-term experience in the development and operation of power supplies resulted in the creation of the MPS-20 (Magnet Power Supply) family of three types of reversible power supplies. The output current of these supplies can be varied in the range of $\pm 20A$; the output voltage is $\pm 50V$, $\pm 100V$, and $\pm 150V$ for MPS-20-50, MPS-20-100, and MPS-20-150, correspondingly. The power supplies developed meet the requirements of the up-to-date accelerator facilities.

INTRODUCTION

A magnetic system of the up-to-date accelerator and storage ring facilities requires a number of different regulated current sources, the large variety of which complicates the operation of a facility as a whole. That is why the goal of this work was to develop universal current sources which could be used at various accelerator facilities.

For instance, the precision experiments with colliding electron-positron beams requires a very stable magnetic field of the collider, which constrains the long-term instability of the output supply current for the magnets.

The acceleration of a charged particle beam requires good dynamic of magnetic field dynamics in an equilibrium orbit. Thus it is necessary to regulate the current in the windings of the magnetic elements in the parts of energy variation: during the energy boost in the acceleration mode and during the reduction to the injection energy. Since the impedance of corrector is the sum of the resistive impedance and the active impedance, a reverse polarity voltage is often required for regulation of the current decreasing. Thus current sources with a 4-quadrant current/voltage operation are required.

CURRENT SOURCE STRUCTURE

The circuit design was special subject to the possibility of realization of the required algorithms for the output current regulation with a high efficiency of the power supply for electromagnets. The design chosen is based on a circuit with double RF conversion (Fig. 1)

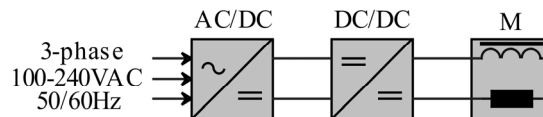

Figure 1: AC/DC and DC/DC are the Alternating current / Direct current and Direct current / Direct current converters; M is the electromagnet.

AC/DC converters with isolated output voltage are used to get a DC buffer voltage. Those are usually conventional AC/DC converters, industrially manufactured voltage stabilizers. The output current is regulated with a DC/DC converter, a schematic diagram of which is given in Fig.2. The power part of the unit

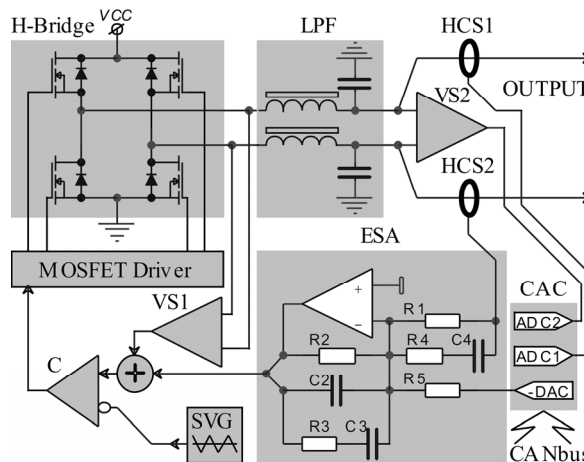

Figure 2: H-Bridge – H-Bridge inverter, LPF – Low-pass filter, HCS – Hall Current Sensors, VS – Voltage sensor, ESA – Error-signal amplifier, CAC – Controller with the CANbus interface, ADC – Analog-to-digital converter, DAC – Digital-to-analog converter, C – Comparator, SVG – Sawtooth-voltage generator.

includes the H-Bridge made on four MOSFET switches. The output current is regulated by the pulse width modulation of the output voltage of the bridge inverter. A second-order filter, LPF, is used to suppress voltage of the carrier frequency and its harmonics. Its suppression ratio is 60 dB or more.

The output current is measured with two identical noncontact Hall current sensors HCS1 and HCS2 of the current – compensating type. One sensor is used in the feedback loop; the other serves as an independent monitor for the control system.

The current-feedback loop provides the required quality of regulation. The mains ripple of 50÷360Hz is partially

suppressed by the AC/DC converter and partially by a fast voltage-feedback loop with a loop amplification factor of about 10.

The current-feedback loop contains the error-signal amplifier, ESA, including of integrating and differentiating elements. The transfer function of these elements with integral characteristics is:

$$W_I(p) = \frac{k_U \cdot (p \cdot T_3 + 1)}{p^2 \cdot T_2 \cdot T_3 + p \cdot (T_2 + T_3 + T_{23}) + 1}$$

Their time constants are:

$$T_2 = R_2 \cdot C_2, T_3 = R_3 \cdot C_3, T_{23} = R_2 \cdot C_3.$$

Such a structure makes it possible to realize a high static gain in the loop of error signal:

$$k_U = \frac{R_2}{R_1} \approx 10^3.$$

In a system with a transfer function W_I , a fast change in the driving control signal can result in an overshoot due to the delay in the regulator of the closed feedback loop system. So, an element with a differentiating characteristic is added, the transfer function of which is

$$W_6(p) = \frac{p \cdot (T_{14} + T_4) + 1}{pT_4 + 1},$$

where $T_{14} = R_1 C_4$ and $T_4 = R_4 C_4$ are the differentiation time constants.

Fig.3 presents the logarithmic gain-frequency response and the phase-frequency characteristic of the open feedback loop. The unity gain frequency (from the plot) is

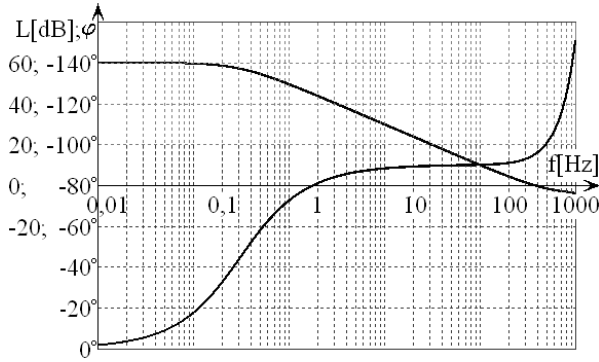

Figure 3: L is for the gain-frequency response, ϕ is for the phase-frequency characteristic.

about 300Hz, and the phase is approximately $\pi/2$, which corresponds to a well-damped system.

In dynamics, e.g. when the current is changing with a frequency of the order of 1Hz, the gain of the open feedback loop is approximately 100, and the time delay in the output current is about 20mS, which is quite enough for most acceleration objectives.

Parameters of the 20A current sources are given in Table 1.

Table 1: Parameters of the 20A current sources

Parameters	Magnet Power Supply
Output current	$\pm 20A$
Output voltage MPS-20-50 MPS-20-100 MPS-20-150	$\pm 50V$ $\pm 100V$ $\pm 150V$
Current accuracy	$\leq 0,1\%$
Output current dispersion	100ppm
Thermal drift of output current	40ppm/K
Conversion frequency	50kHz
Cooling	Air Forced

DESIGN

The 20A current sources are made in a standard "Euromechanics" crate of a 3U-subunit (432×355×133mm). The modules can be fed from both 120/208VAC and 220/380VAC, 50/60Hz mains.

The current sources are managed with the module-embedded analog-to-digital controller CEAC124, developed by BINP [2]. The controller contains 4 channels of a 16-bit bipolar analog-to-digital controller, 12 channels of a 24-bit analog-to-digital controller as well as 4 channels of input signal registers and 4 channels of output signal registers. The controller is connected with the control system via the CANbus.

The controller allows the power supply to work independently in the static and dynamic modes. In the static mode, the module works as a direct current source. In the dynamic mode, the controller can use the internal data chart. The controller approximates those data by the method of straight-line interpolation, and the current is regulated in accordance with a given time dependence with a step of about 10mS.

There are two ways of external control of the module parameters: (1) via the multichannel scanning of selected channels, (2) in the digital oscilloscope mode, which allows one to measure one selected channel with a higher time resolution of about 1mS. The multichannel scanning mode is mainly applied to control the current and voltage during the operation of the current sources. The digital oscilloscope mode is used, for instance, for the spectral analysis of the values to measure [3].

Up to two external binary signals with the ON/OFF operation command can be connected to the power supplies. Those can be signals of a thermostwitch and a water flow switch for a water-cooled load.

On the front panel of the module (Fig.4) there are digital indicators for the output current and the output voltage as well as two LED indicators informing on the availability of backup power supply and operation of the protection circuit. The protection operates when the

current in the inverter half-bridge exceeds the admissible value. In this case, the operation of the power part of the converter is blocked, a pause is sustained, and then an automatic restart occurs with a frequency of about 1Hz. The input signal register of the controller is used to notify the control computer on the protection operation.

RESULTS

About fifty of 20A current sources are now working on different BINP facilities as well as at JINR (Dubna) and other installations. Several years of operation have proved the reliability of their work.

REFERENCES

- [1] O. Belikov. Current sources for the correction magnets in accelerators and storage rings. Abstract of a thesis for PhD in Technical Sciences.
- [2] V. Kozak. Euromechanical device set with CANbus interface, Preprint Budker INP 2008-18, Novosibirsk (2008).
- [3] O. Belikov et al. System of power supply ripples measurement for VEPP-2000 collider, RuPAC 2008, p. 178-180, Zvenigorod (2008).



Figure 4: Magnet power supply MPS-20