

FOUR-QUADRANT POWER SUPPLIES FOR STEERING ELECTROMAGNETS FOR ELECTRON-POSITRON COLLIDERS

O. Belikov, V. Kozak, A. Medvedko, BINP, Novosibirsk, Russia.

Abstract

Specialized power supplies for electromagnets for accelerators and charged particle storage rings have been designed and manufactured at Budker Institute of Nuclear Physics for many years [1]. It turned out to be optimal to divide power supplies for correction elements into two groups according to their output parameters. This work presents two types of power supplies for steering magnets with a maximum output current of $\pm 6\text{A}$ (MPS-6) and $\pm 25\text{A}$ (MPS-25). The power supplies are manufactured under the Switch Mode Technology in the "Euromechanics" standard with application of up-to-date components.

INTRODUCTION

The quality of operation of electron-positron collider is defined by the beam energy stability. Direct dependence of the beam energy on the magnetic field value imposes requirements on the quality of power supplies for the magnet system. Instability of the relation between the magnet current and its field is mainly defined by the hysteresis, variation in the magnetic permeability value, and dependence of the magnetic circuit gap on temperature. The field temperature coefficient is about 10ppm/K. Therefore for most tasks it is reasonable to feed bending magnets with current with adjustment accuracy of the order of 10^{-5} from the operation value. The variation in the initial parameters of the magnetic circuit as well as the error of magnet alignment is less than 1%. That is why in most cases it is possible to manage with magnetic field corrections with flatness less than 1% from that of bending magnets. Therefore, the error of current adjustment in the trim coils for equilibrium orbit should be 10^{-3} or better.

Table 1:

Parameters	Magnet Power Supply MPS-6	Magnet Power Supply MPS-25
Output current	$\pm 6\text{ A}$	$\pm 25\text{ A}$
Current accuracy	$\leq 0,1\%$	$\leq 0,1\%$
Output voltage	$\pm 100\text{V}$	$\pm 100\text{V}$
Control	DAC/ADC	DAC/ADC
Cooling	Air Natural	Air Forced
Conversion frequency	50kHz	50kHz
Overall dimension	51×227×266mm	432×355×133mm

Detached dipole correctors of electron-positron colliders are mainly cooled with air and power released in a coil does not exceed 500W. Besides, there are multipole correctors that can be fed in a serial connection. In such case, the total power released in coils is as great as 2 kW. We have developed the MPS-6 and MPS-25 power supplies for these correctors. Main parameters of MPS-6 and MPS-25 are presented in Table 1.

SCHEMATIC CIRCUIT OF THE POWER

Fig.1 presents the schematic circuit of the power

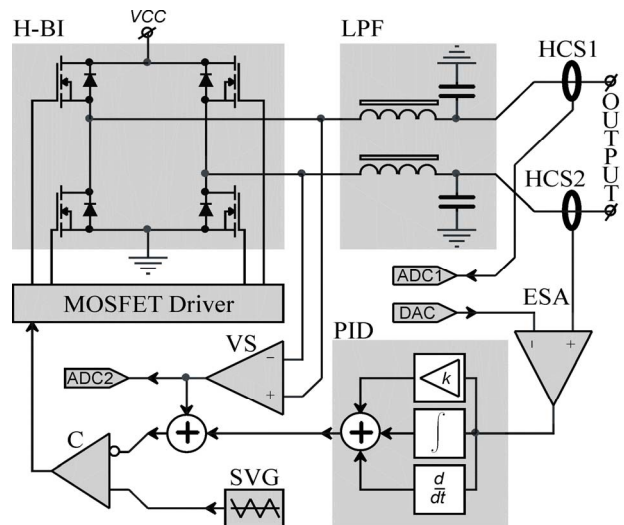

Figure 1: H-BI – H-Bridge inverter. LPF – Low-pass filter. HCS – Hall Current Sensors. PID – Proportional-Integral-Derivative Controller. ADC – Analog-to-digital converter. VS – Voltage sensor. C – comparator. ESA – Error-signal amplifier. SVG – Sawtooth-voltage generator. DAC – Digital-to-analog converter.

supplies MPS-6 and MPS-25. The output current is adjusted by the pulse-length modulation of the output voltage of the bridge inverter H-BI. There is a second order passive filter LPF at the output of the bridge inverter. The feedback circuit includes a proportion-integral-derivative (PID) controller, which provides the required accuracy of adjustment in the static regime as well as prevents from overcontrol when the job is changed. In order to suppress pulsations of the supply mains with frequencies of 50÷300Hz, we introduce a faster voltage feedback circuit

The option of operative replacement of the unit is provided, i.e. the MPS-6 units can be replaced in an operating module, without de-energization of the cabinet comprising the units.

The power supplies are equipped with two identical non-contact current sensors of the compensation type

(HCS) incorporated in the output circuit (after the filter). One of the sensors is used in the feedback circuit and the second one operates as an independent meter for the control system.

The monitoring and control system for the power supplies implies application of an external controller with one DAC channel to set current, two ADC channels to measure current and voltage, one bit of the input register (for switching on/off), and one bit of the output register (for reporting a mistake in the power supply operation to the control system). A mistake in the MPS-6 operation can arise at a trim coil contact to frame. In this case, the protection circuit locks operation of the bridge inverter, holds a pause of 1 sec and then the power supply is automatically started again.

POWER SUPPLY MPS-6

The power supplies MPS-6 are manufactured as an insertion unit in the “Euromechanics” standard. Since a modern collider has several hundreds of such power supplies, we paid a large attention to the development of multi-channel module. The Subrack realization, a 6U subunit (432×415×266mm), which includes 8 power supplies MPS-6, controller CEAC208 [2], and backup and auxiliary power supplies, turned out to be the optimal one (Fig.2). The module is fed from a 200÷240V, 50/60Hz mains (there are options of 90÷130V supply voltages). Commutations between the MPS-6 units and controller CEAC208 are realized on the mother board. A scheme of recuperation of energy accumulated in the inductors of the coils of correctors is also provided.

Feeding all channels of the MPS-6 module from one power supply makes it possible to use the backup supplies more efficiently because the total consumption power is always less than the maximum possible one since, as a rule, all correction elements do not work simultaneously

at maximum current. In addition to output current and voltage, the control system can also measure current and voltage of the backup power supply.

The CEAC208 controller monitors and controls the MPS-6 module via the CAN-bus. The static and dynamic regimes of module operation are possible. In the static regime, all channels work as DC sources. In the dynamic regime, each channel is provided with a data table according to which the device stabilizes varying current by the method of piecewise-linear interpolation. Channels within one module are controlled synchronously in time. The supply channels can be controlled in two ways: via the multi-channel scanning of selected channels and in the digital oscillograph regime. In the second case, it is possible to measure one selected channel with a higher time resolution. Measurement results are output to the CAN-bus line and are recorded in the inner cyclic buffer of a controller for 4096 measurements. The control computer can interrupt the measurement process at any moment and read the buffer value.

MPS-25 POWER SUPPLY

The power supply MPS-25 is manufactured in the “Euromechanics” standard as a 3U subunit Subrack (432×355×133mm). It includes the controller CEAC124 [3] and backup and auxiliary power supplies (Fig.3). The module is fed from a 200÷240V, 50/60Hz mains.

The power supply MPS-25 is monitored and controlled is the same way as the power supply MPS-6 is, via the CAN-bus. In addition to the unit of the controller CEAC124, the MPS-25 power supply allows connecting up to two external signals of binary permission/inhibition commands. The user can turn on the option of remote (from the control computer) switching on/off of the power part of the power supply.



Figure 2: 8-channel module MPS-6

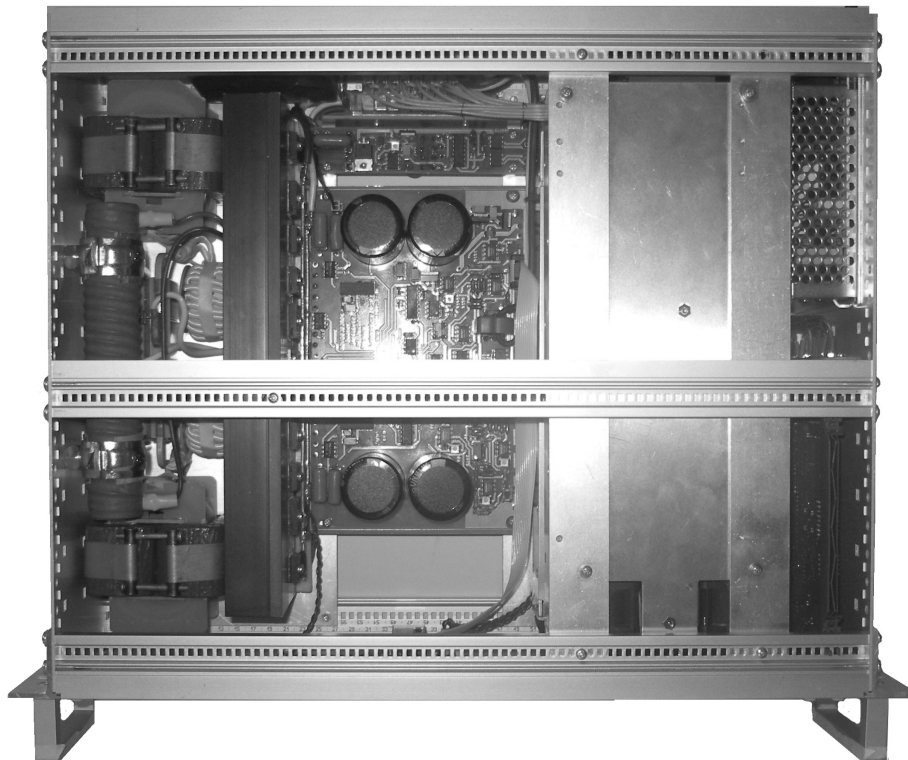

Figure 3: Magnet power supply MPS-25

TESTS AND RESULTS

The described power supplies are manufactured by BINP and work successfully at physical facilities in Russia and abroad. In total, 200 power supplies MPS-6 and about 50 power supplies MPS-25 have been manufactured. Analysis of the results of long-term stability tests of the power supplies with a $\pm 10\%$ variation in the supply line voltage and a $\pm 20\%$ variation in the load resistance at an ambient temperature of $20 \div 50^{\circ}\text{C}$ showed that output current instability did not exceed the stated precision. The output current precision is of the order of 100ppm for 10 hours of operation.

REFERENCES

- [1] O. Belikov et al. Power amplifiers UM-6 and UM-20 to supply the corrector magnets of the VEPP-2000 storage ring, Budker INP preprint 2007-14, Novosibirsk (2007).
- [2] V. Kozak, M. Romakh. Devices with CANBUS interface for automation systems of physical installations (Modules CAC208, CURVV), Budker INP preprint 2004-68, Novosibirsk (2004).
- [3] V. Kozak. Euromechanical device set with CANbus interface, Budker INP preprint 2008-18, Novosibirsk (2008).