

**MYSTERIES OF THE
EQUILATERAL TRIANGLE**

Brian J. M^cCartin

Applied Mathematics
Kettering University

HIKARI LTD

HIKARI LTD

Hikari Ltd is a publisher of international scientific journals and books.

www.m-hikari.com

Brian J. McCartin, MYSTERIES OF THE EQUILATERAL TRIANGLE,
First published 2010.

No part of this publication may be reproduced, stored in a retrieval system,
or transmitted, in any form or by any means, without the prior permission of
the publisher Hikari Ltd.

ISBN 978-954-91999-5-6

Copyright © 2010 by Brian J. McCartin

Typeset using L^AT_EX.

Mathematics Subject Classification: 00A08, 00A09, 00A69, 01A05,
01A70, 51M04, 97U40

Keywords: equilateral triangle, history of mathematics, mathematical bi-
ography, recreational mathematics, mathematics competitions, applied math-
ematics

Published by Hikari Ltd

Dedicated to our beloved

Beta Katzenteufel

for completing our equilateral triangle.



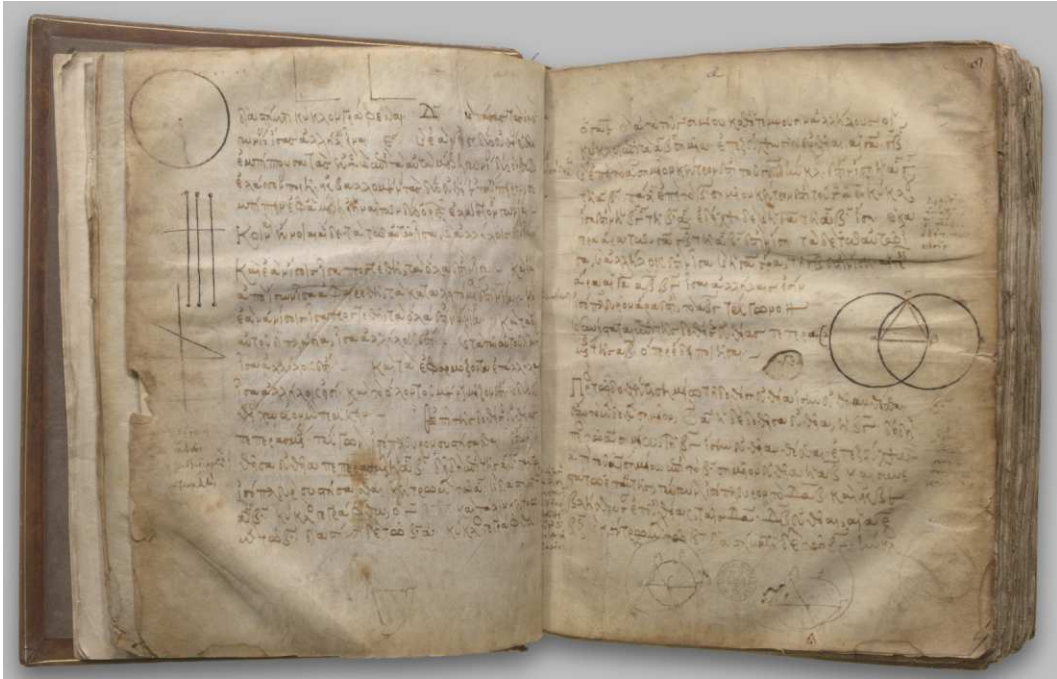

Euclid and the Equilateral Triangle
(*Elements*: Book I, Proposition 1)

PREFACE

Welcome to *Mysteries of the Equilateral Triangle (MOTET)*, my collection of equilateral triangular arcana. While at first sight this might seem an idiosyncratic choice of subject matter for such a detailed and elaborate study, a moment's reflection reveals the worthiness of its selection.

Human beings, “being as they be”, tend to take for granted some of their greatest discoveries (witness the wheel, fire, language, music,...). In Mathematics, the once flourishing topic of Triangle Geometry has turned fallow and fallen out of vogue (although Phil Davis offers us hope that it may be resuscitated by The Computer [70]). A regrettable casualty of this general decline in prominence has been the Equilateral Triangle.

Yet, the facts remain that Mathematics resides at the very core of human civilization, Geometry lies at the structural heart of Mathematics and the Equilateral Triangle provides one of the marble pillars of Geometry. As such, it is the express purpose of the present missive, *MOTET*, to salvage the serious study of the equilateral triangle from the dustbin of Mathematical History [31].

Like its musical namesake, *MOTET* is polyphonic by nature and requires no accompaniment [10]. Instead of being based upon a sacred Latin text, it rests upon a deep and abiding mathematical tradition of fascination with the equilateral triangle. The principal component voices are those of mathematical history, mathematical properties, Applied Mathematics, mathematical recreations and mathematical competitions, all above a basso ostinato of mathematical biography.

Chapter 1 surveys the rich history of the equilateral triangle. This will entail a certain amount of globetrotting as we visit Eastern Europe, Egypt, Mesopotamia, India, China, Japan, Sub-Saharan Africa, Ancient Greece, Israel, Western Europe and the United States of America. This sojourn will bring us into contact with the religious traditions of Hinduism, Buddhism, Judaism, Christianity and Scientology. We will find the equilateral triangle present within architecture, sculpture, painting, body armour, basket weaving, religious icons, alchemy, magic, national flags, games, insects, fruits and vegetables, music, television programs and, of course, Mathematics itself. N.B.: Circa 1000 A.D., Gerbert of Aurillac (later Pope Sylvester II) referred to the equilateral triangle as “mother of all figures” and provided the formula $A \approx s^2 \cdot 3/7$ which estimates its area in terms of the length of its side to within about 1% (N. M. Brown, *The Abacus and the Cross*, Basic, 2010, p. 109).

Chapter 2 explores some of the mathematical properties of the equilateral triangle. These range from elementary topics such as construction procedures to quite advanced topics such as packing and covering problems. Old chestnuts like Morley's Theorem and Napoleon's Theorem are to be found here, but so are more recent rarities such as Blundon's Inequality and Partridge Tiling.

Many of these plums may be absorbed through light skimming while others require considerable effort to digest. *Caveat emptor*: No attempt has been made either to distinguish between the two types or to segregate them.

In Chapter 3, we take up the place of the equilateral triangle in Applied Mathematics. Some of the selected applications, such as antenna design and electrocardiography, are quite conventional while others, such as drilling a square hole and wrapping chocolates, are decidedly unconventional. I have based the selection of topics upon my desire to communicate the sheer breadth of such applications. Thus, the utilization of the equilateral triangle in detecting gravitational waves, the construction of superconducting gaskets, cartography, genetics, game theory, voting theory *et cetera* have all been included.

The subject of Chapter 4 is the role of the equilateral triangle in Recreational Mathematics. Traditional fare such as dissection puzzles appear on the menu, but so do more exotic delicacies such as rep-tiles and spidrons. Devotees of the work of Martin Gardner in this area will instantly recognize my considerable indebtedness to his writings. Given his extensive contributions to Recreational Mathematics, this pleasant state of affairs is simply unavoidable.

Chapter 5 contains a collection of olympiad-caliber problems on the equilateral triangle selected primarily from previous Mathematical Competitions. No solutions are included but readily available collections containing complete solutions are cited chapter and verse. Unless otherwise attributed, the source material for the biographical vignettes of Chapter 6 was drawn from *Biographical Dictionary of Mathematicians* [144], *MacTutor History of Mathematics* [230] and *Wikipedia, The Free Encyclopedia* [330]. Finally, we bid adieu to the equilateral triangle by taking a panoramic view of its many manifestations in the world about us. Thus, *MOTET* concludes with a Gallery of Equilateral Triangles that has been appended and which documents the multifarious and ubiquitous appearances of the equilateral triangle throughout the natural and man-made worlds.

I owe a steep debt of gratitude to a succession of highly professional Interlibrary Loan Coordinators at Kettering University: Joyce Keys, Meg Wickman and Bruce Deitz. Quite frankly, without their tireless efforts in tracking down many times sketchy citations, whatever scholarly value may be attached to the present work would be substantially diminished. Also, I would like to warmly thank my Teachers: Harlon Phillips, Oved Shisha, Ghasi Verma and Antony Jameson. Each of them has played a significant role in my mathematical development and for that I am truly grateful. Once again, my loving wife Barbara A. (Rowe) McCartin has lent her Mathematical Artistry to the cover illustration thereby enhancing the appearance of this work.

Brian J. McCartin
Fellow of the Electromagnetics Academy
Editorial Board, *Applied Mathematical Sciences*

Contents

Preface	v
1 History of the Equilateral Triangle	1
2 Mathematical Properties of the Equilateral Triangle	29
3 Applications of the Equilateral Triangle	78
4 Mathematical Recreations	103
5 Mathematical Competitions	129
6 Biographical Vignettes	148
A Gallery of Equilateral Triangles	188
Bibliography	199
Index	221

Chapter 1

History of the Equilateral Triangle

The most influential Mathematics book ever written is indisputably Euclid's *The Elements* [164]. For two and a half millenia, it has been the Mathematician's lodestone of logical precision and geometrical elegance. Its influence was even felt in the greatest physics book ever written, Newton's *Principia Mathematica* [227]. Even though Newton certainly discovered much of his mechanics using calculus, he instead presented his results using the geometrical techniques of Euclid and even the organization of the text was chosen to model that of *The Elements*. It should be pointed out, however, that *The Elements* has been scathingly criticised by Russell [260] on logical grounds.

As is evident from the Frontispiece, at the very outset of *The Elements* (Book I, Proposition I), Euclid considers the construction of an equilateral triangle upon a given line segment. However, this is far from the first appearance of the equilateral triangle in human history. Rather, the equilateral triangle can be found in the very earliest of human settlements.

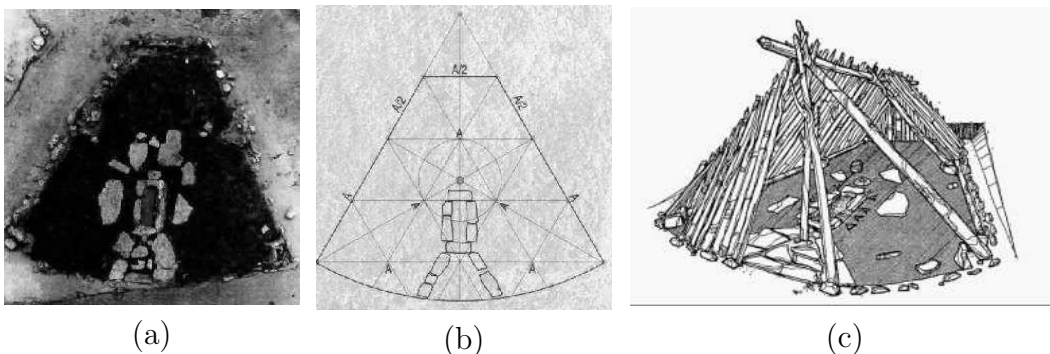

Figure 1.1: Mesolithic House at Lepenski Vir (6000 B.C.): (a) Photo of Base of House. (b) Geometry of Base of House. (c) Sloped Thatched Walls. [289]

Lepenski Vir, located on the banks of the Danube in eastern Serbia, is an important Mesolithic archeological site [289]. It is believed that the people of Lepenski Vir represent the descendents of the early European hunter-gatherer culture from the end of the last Ice Age. Archeological evidence of human habitation in the surrounding caves dates back to around 20,000 B.C. The first settlement on the low plateau dates back to 7,000 B.C., a time when the climate became significantly warmer.

Seven successive settlements have been discovered at Lepenski Vir with remains of 136 residential and sacral buildings dating from 6,500 B.C. to 5,500 B.C.. As seen in Figure 1.1(a), the base of each of the houses is a circular sector of exactly 60° truncated to form a trapezoid. The associated equilateral triangle is evident in Figure 1.1(b). Figure 1.1(c) presents an artist's rendering of how the completed structure likely appeared. The choice of an equilateral triangular construction principle, as opposed to circular or rectangular, at such an early stage ("Stone Age") of human development is really quite remarkable!



Figure 1.2: Snefru's Bent Pyramid at Dahshur

A fascination with the equilateral triangle may also be traced back to Pharaonic Egypt. Snefru (2613-2589 B.C.), first pharaoh of the Fourth Dynasty, built the first non-step pyramid. Known as the Bent Pyramid of Dahshur, it is shown in Figure 1.2. It is notable in that, although it began with a slant angle of 60° (which would have produced an equilateral triangular cross-section), the base was subsequently enlarged resulting in a slant angle of approximately 54° (which would have produced equilateral triangular faces) but, due to structural instability, was altered once again part-way up to a slope of 43° .

Later pyramids, such as the Great Pyramid of Khufu/Cheops (2551-2528 B.C.) at Giza (see Figure 1.3), were built with a more conservative slope of approximately 52° . Although this pyramid is believed to be built based upon the golden mean [118, pp. 161-163], a construction based upon the equilateral triangle [115] has been proposed (see Figure 1.4).

Moving to the Fertile Crescent between the Tigris and Euphrates, we en-



Figure 1.3: Great Pyramid of Khufu at Giza

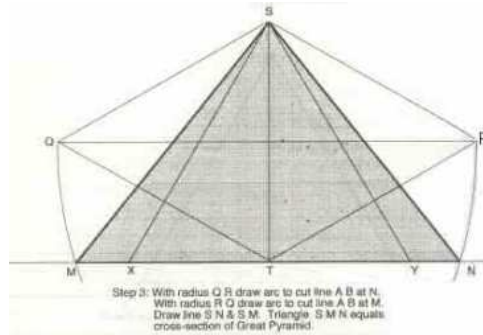

Figure 1.4: Great Pyramid Cross-Section [115]

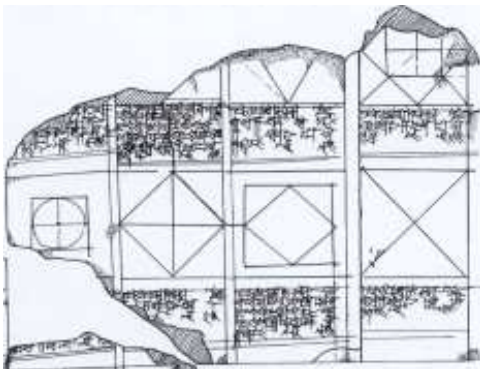

Figure 1.5: Old Babylonian Clay Tablet BM 15285 [259]



Figure 1.6: Iron Haematite Babylonian Cylinder [206]

counter the sister-states of Babylonia and Assyria who competed for dominance over what is now Iraq. Babylonia was a land of merchants and agriculturists presided over by a priesthood. Assyria was an organized military power ruled by an autocratic king.

Old Babylonian clay tablet BM 15285 is a mathematical “textbook” from southern Mesopotamia dating back to the early second-millennium B.C. The portion shown in Figure 1.5 contains a problem which is believed to have involved an approximate construction of the equilateral triangle [259, pp. 198-199]. The iron haematite Babylonian cylinder of Figure 1.6 prominently displays an equilateral triangle as what is believed to be a symbol of a sacred Trinity [206, p. 605]. Such cylinders were usually engraved with sacred figures, accompanied by a short inscription in Babylonian cuneiform characters, containing the names of the owner of the seal and of the divinity under whose protection he had placed himself.

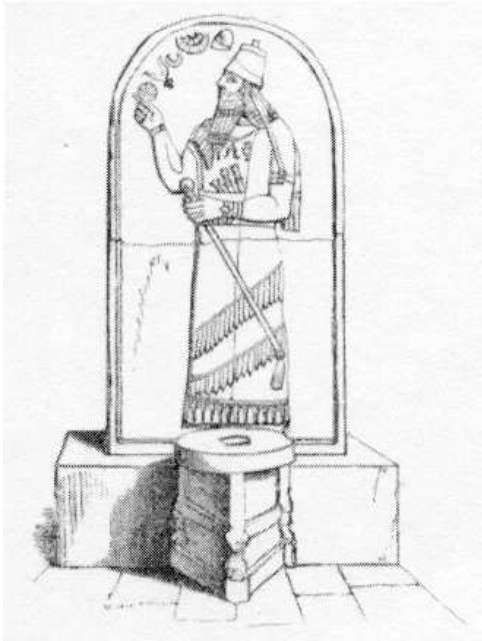

Figure 1.7: Asshur-izir-pal [250]

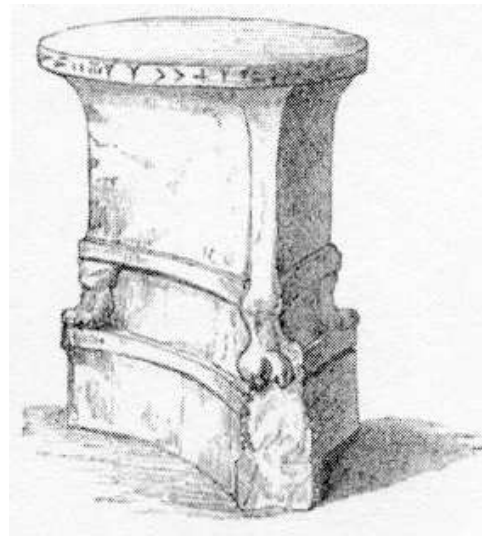

Figure 1.8: Triangular Altar [250]

Figure 1.7 shows a stele of the Assyrian King Asshur-izir-pal excavated at Nimrud [250, p. 97]. In front of this figure, marking the object of its erection, is an equilateral triangular altar with a circular top. Here were laid the offerings to the divine monarch by his subjects upon visiting his temple. Figure 1.8 shows another triangular Assyrian altar excavated at Khorsabad [250, p. 273].

Moving further East, we encounter Hinduism which is the largest and indigenous religious tradition of India [157]. The name *India* itself is derived from the Greek *Indus* which is further derived from the Old Persian *Hindu*.



Figure 1.9: Kali Yantra



Figure 1.10: Chennai Temple [201]

A yantra is a Hindu mystical diagram composed of interlocking geometrical shapes, typically triangles, used in meditation when divine energy is invoked into the yantra by special prayers. Figure 1.9 shows the yantra of Kali (Kalka), Hindu goddess associated with eternal energy. It is composed of five concentric downward-pointing equilateral triangles surrounded by a circular arrangement of eight lotus flowers. The five equilateral triangles symbolize both the five senses and the five *tattvas* (air, earth, fire, water and spirit).

The ancient Marundheeswarar Temple of Lord Shiva in Thiruvannamur, South Chennai has a series of pillars with beautiful geometric designs and mathematical motifs [201]. Figure 1.10 displays a pattern of three overlapping equilateral triangles surrounding a central four-petaled flower. These three equilateral triangles are connected by a Brunnian link in that no two of them are linked together but the three are collectively linked; if one of the triangles is removed then the other two fall apart. These pillars are located near the sanctum of the goddess Tripurasundari, “belle of the three cities”. The implied triad of this motif is pregnant with symbolism. The archetypal mantra *Aum* has three parts; the yogi’s three principal *nadis* (bodily energy channels) of the *ida*, the *pengala* and the *sushumna* form a core tantric triad; the three *sakthis* (powers) derived from the goddess are the *iccha* (desire), the *gnana* (knowledge) and the *kriya* (action); and, of course, there is the triad of Brahma (The Creator), Vishnu (The Preserver) and Shiva (The Destroyer).

Reaching the Orient, in traditional Chinese architecture, windows were

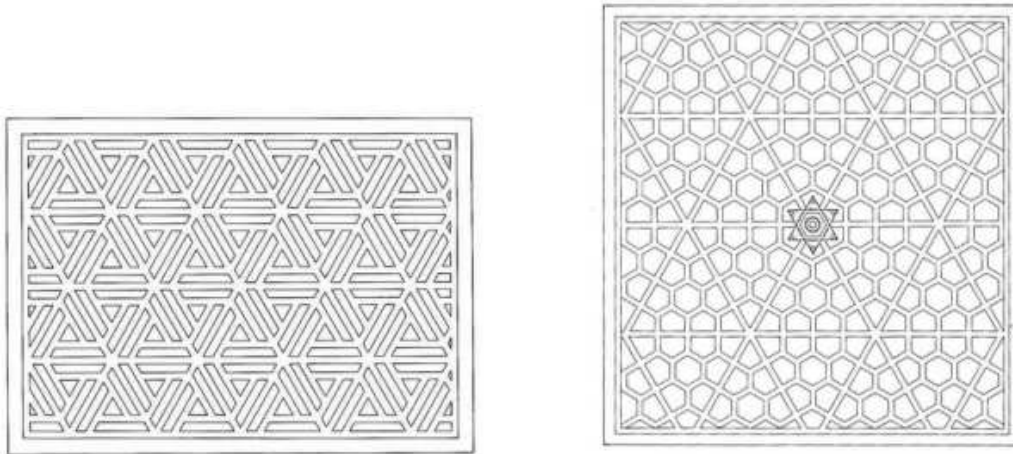

Figure 1.11: Chinese Window Lattices [91]

made of a decorative wooden lattice with a sheet of rice paper glued to the inside in order to block the draft while letting in the light. Iconographic evidence traces such lattices all the way back to 1000 B.C. during the Chou Dynasty. They reached their full development during the Qing Dynasty beginning in 1644 A.D. when they began to display a variety of geometrical patterns [217]. Figure 1.11 displays two such examples with an equilateral triangular motif [91].

The Three Pagodas of Chongsheng Monastery are an ensemble of three independent pagodas arranged at the vertices of an equilateral triangle located near the town of Dali in the Yunnan Province of China (Figure 1.12). Unique in China, legend has it that the Three Pagodas were built to deter natural disasters created by dragons [333]. The main pagoda, known as Qianxun Pagoda, was built during 824-840 A.D. by King Quan Fengyou of the Nanzhao state. Standing at 227 feet, it is one of the highest pagodas of the Tang Dynasty (618-907 A.D.). This central pagoda is square-shaped and is composed of sixteen stories, each story with multiple tiers of upturned eaves. There is a carved shrine containing a white marble sitting Buddha statue at the center of each facade of every story. The body of the pagoda is hollow from the first to the eighth story and was used to store sculptures and documents. The other two sibling pagodas, built around one hundred years later, stand to the northwest and southwest of Qianxun Pagoda. They are both solid and octagonal with ten stories and stand to a height of 140 feet. The center of each side of every story is decorated with a shrine containing a Buddha statue.

During the Edo period (1603-1867), when Japan isolated itself from the western world, the country developed a traditional Mathematics known as



Figure 1.12: The Three Pagodas (900 A.D.)

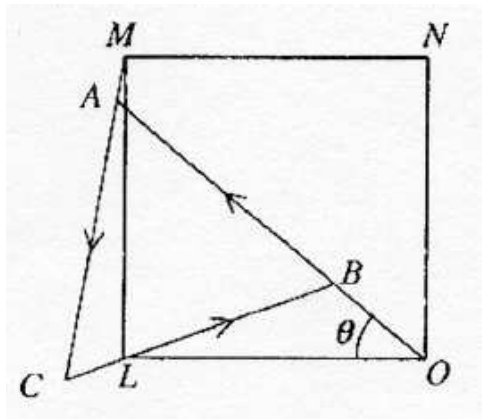

Figure 1.13: Japanese Mathematics: Wasan [299]

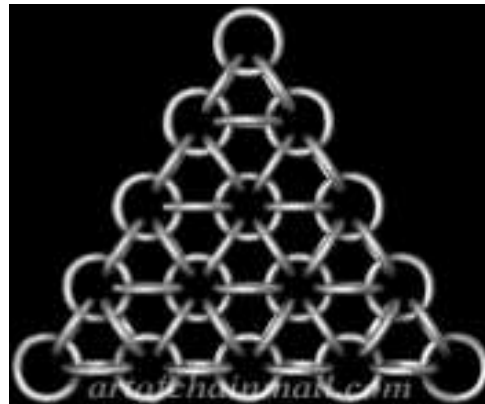

Figure 1.14: Japanese Chainmail: Hana-Gusari [329]

Wasan which was usually stated in the form of problems, eventually appearing in books which were either handwritten with a brush or printed from wood blocks. The problems were written in a language called *Kabun*, based on Chinese, which cannot be readily understood by modern Japanese readers even though written Japanese makes extensive use of Chinese characters [111]. One such problem due to Tumugu Sakuma (1819-1896) is illustrated in Figure 1.13. The sides AB , BC and CA of an equilateral triangle ABC pass through three vertices O , L and M of a square. Denoting the lengths of OA , LB and MC by a , b and c , respectively, show that $a = (\sqrt{3} - 1)(b + c)$ [299]. F. Suzuki has subsequently generalized this problem by replacing the square by an isosceles triangle [300]. (See Recreation 27: *Sangaku Geometry*.)

Chainmail is a type of armour consisting of small metal rings linked together in a pattern to form a mesh. The Japanese used mail (*kusari*) beginning in the Nambokucho period (1336-1392). Two primary weave patterns were used: a square pattern (*so gusari*) and a hexagonal pattern (*hana gusari*). The base pattern of *hana gusari* is a six-link equilateral triangle (Figure 1.14) thereby permitting polygonal patterns such as triangles, diamonds and hexagons [329]. These were never used for strictly mail shirts, but were instead used over padded steel plates or to connect steel plates. The resulting mail armour provided an effective defense against slashing blows by an edged weapon and penetration by thrusting and piercing weapons.

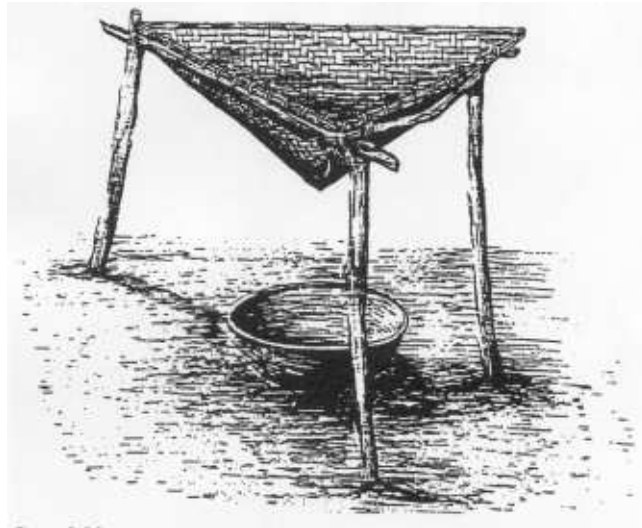

Figure 1.15: African *Eheleo* Funnel [140]

The equilateral triangle appears in many other human cultures. In order to illustrate this, let us return for a moment to the African continent. A pyramidal basket, known as *eheleo* in the Makhuwa language, is woven in

regions of Sub-Saharan Africa such as the North of Mozambique, the South of Tanzania, the Congo/Zaire region and Senegal [140]. In Mozambique and Tanzania, it is used as a funnel in the production of salt. As seen in Figure 1.15, the funnel is hung on a wooden skeleton and earth containing salt is inserted. A bowl is placed beneath the funnel, hot water is poured over the earth in the funnel, saltwater is caught in the bowl and, after evaporation, salt remains in the bowl. The *eheleo* basket has the form of an inverted triangular pyramid with an equilateral triangular base and isosceles right triangles as its three remaining faces.

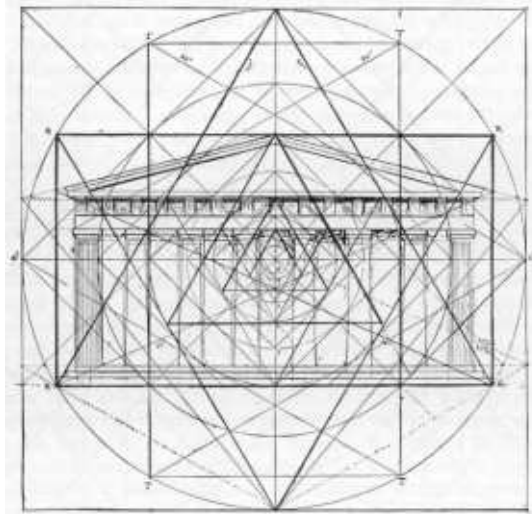

Figure 1.16: Parthenon and Equilateral Triangles [54]

We turn next to the cradle of Western Civilization: Ancient Greece. Figure 1.16 shows the portico of the Parthenon together with superimposed concentric equilateral triangles, each successive triangle diminished in size by one-half [54]. This diagram “explains” the inscribing rectangle, the position of the main cornice, the underside of the architrave, and the distance between the central columns.

The Pythagorean Tetraktys is shown in Figure 1.17, which is from Robert Fludd’s *Philosophia Sacra* (1626), where the image shows how the original absolute darkness preceded the Monad (1), the first created light; the Dyad (2) is the polarity of light (Lux) and darkness (Tenebrae), with which the Humid Spirit (Aqua) makes a third; the combination of the four elements (Ignis, Aer, Aqua, Terra) provides the foundation of the world. To the Pythagoreans, the first row represented zero-dimensions (a point), the second row one-dimension (a line defined by two points), the third row two-dimensions (a plane defined by a triangle of three points) and the fourth row three-dimensions (a tetrahedron

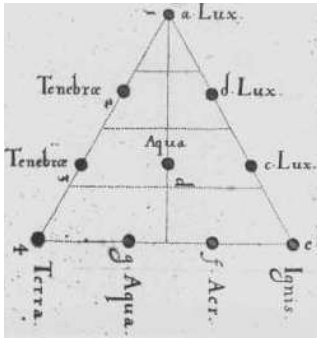

Figure 1.17: Pythagorean Tetraktys

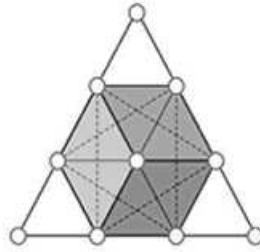

Figure 1.18: Neopythagorean Tetraktys

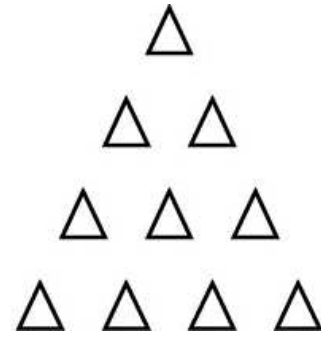

Figure 1.19: Triangular Numbers

defined by four points). Together, they symbolized the four elements: earth, air, fire and water. The tetraktys (four) was seen to be the sacred decad (ten) in disguise ($1+2+3+4=10$). It also embodies the four main Greek musical harmonies: the fourth (4:3), the fifth (3:2), the octave (2:1) and the double octave (4:1) [148].

For neopythagoreans [276], the tetraktys' three corner dots guard a hexagon (6, symbolizing life) and the hexagon circumscribes a mystic hexagram (two overlapping equilateral triangles, upward-pointing for male and downward-pointing for female, denoting divine balance) enclosing a lone dot (Figure 1.18). This dot represents Athene, goddess of wisdom, and symbolizes health, light and intelligence. The tetraktys is also the geometric representation of the fourth of the triangular numbers $\Delta_n = \frac{n(n+1)}{2}$ (Figure 1.19).



Figure 1.20: Hebrew Tetragrammaton



Figure 1.21: Archbishop's Coat of Arms

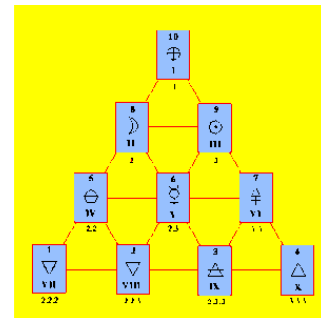

Figure 1.22: Tarot Card Spread

The tetraktys has also been passed down to us in the Hebrew Tetragrammaton of the Kabbalah (Figure 1.20) and the Roman Catholic archbishop's coat of arms (Figure 1.21). The tetraktys is also used in one Tarot card reading arrangement (Figure 1.22). The various positions provide a basis for forecasting future events.

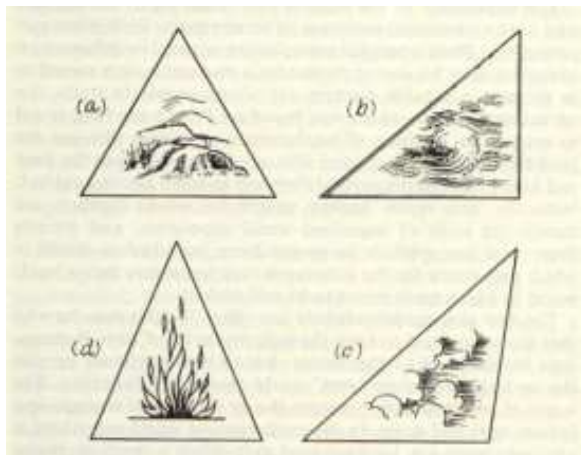

Figure 1.23: Platonic Triangles: (a) Earth. (b) Water. (c) Air. (d) Fire. [176]

In his *Timaeus*, Plato symbolizes ideal or real Earth as an Equilateral Triangle [176, pp. 16-17] (Figure 1.23). A Platonic (regular) solid is a convex polyhedron whose faces are congruent regular polygons with the same number of faces meeting at each vertex. Thus, all edges, vertices and angles are congruent. Three of the five Platonic solids have all equilateral triangular faces (Figure 1.24): the tetrahedron (1), octahedron (3) and icosahedron (4) [66]. Of the five, only the cube (2) can fill space. The isosahedron, with its twenty equilateral triangular faces meeting in fives at its twelve vertices, forms the logo of the Mathematical Association of America. By studying the Platonic solids, Descartes discovered the polyhedral formula $P = 2F + 2V - 4$ where P is the number of plane angles, F is the number of faces, and V is the number of vertices [3]. Euler independently introduced the number of edges E and wrote his formula as $E = F + V - 2$ [252].

Figure 1.24, which was derived from drawings by Leonardo da Vinci, has an interesting history [44]. Because Leonardo was born on the wrong side of the blanket, so to speak, he was denied a university education and was thus “unlettered”. This meant that he did not read Latin so that most formal learning was inaccessible to him. As a result, when he was middle-aged, Leonardo embarked on an ambitious program of self-education that included teaching himself Latin. While in the employ of Ludovico Sforza, Duke of Milan, he made the fortuitous acquaintance of the famous mathematician Fra Luca Pacioli. Pacioli guided his thorough study of the Latin edition of Euclid’s *Elements* thereby opening a new world of exploration for Leonardo. Soon after, Leonardo and Fra Luca decided to collaborate on a book. Written by Pacioli and illustrated by Leonardo, *De Divina Proportione* (1509) contains an extensive review of proportion in architecture and anatomy, in particular the

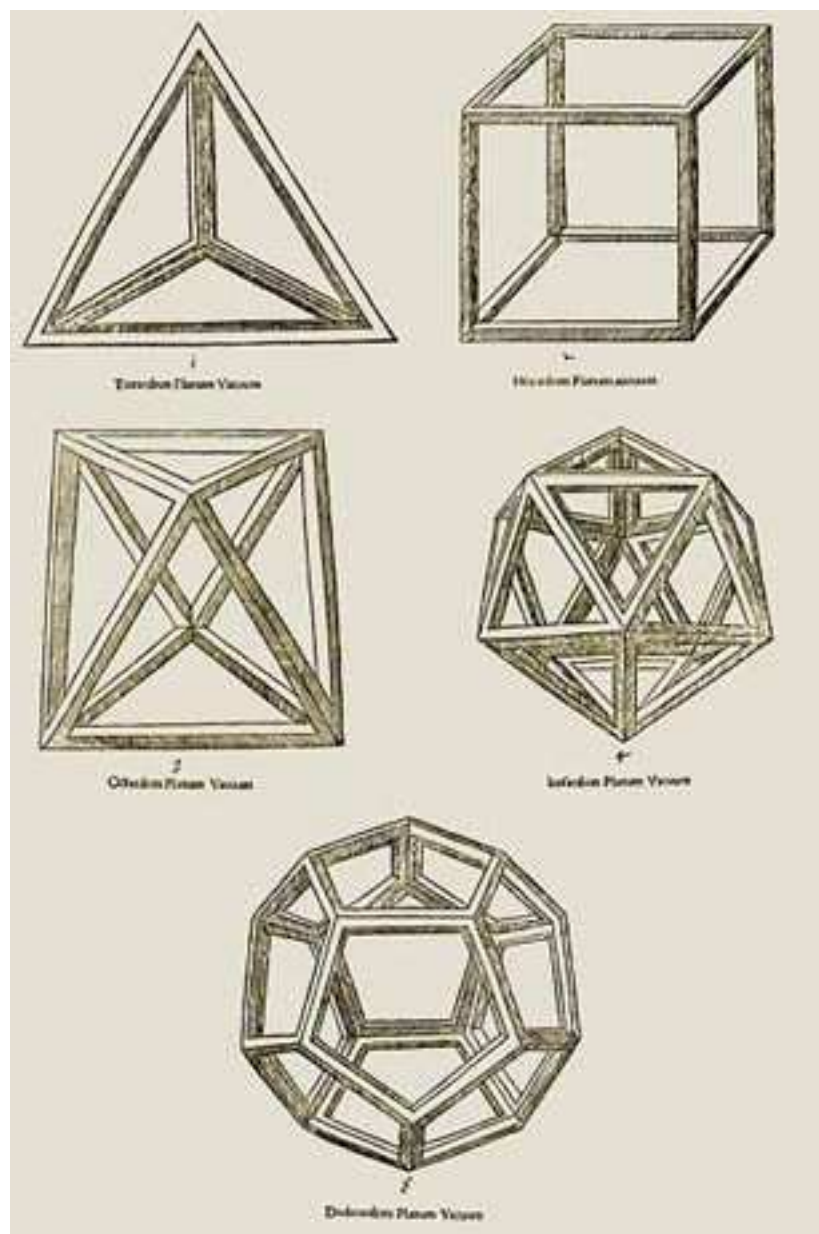

Figure 1.24: Five Platonic Solids

golden section, as well as detailed discussions of the Platonic solids. It contains more than sixty illustrations by Leonardo including the skeletal forms of the Platonic solids of Figure 1.24. It is notable that this is the only collection of Leonardo's drawings that was published during his lifetime. Remarkably, this work was completed contemporaneously with his magnificent *The Last Supper*.

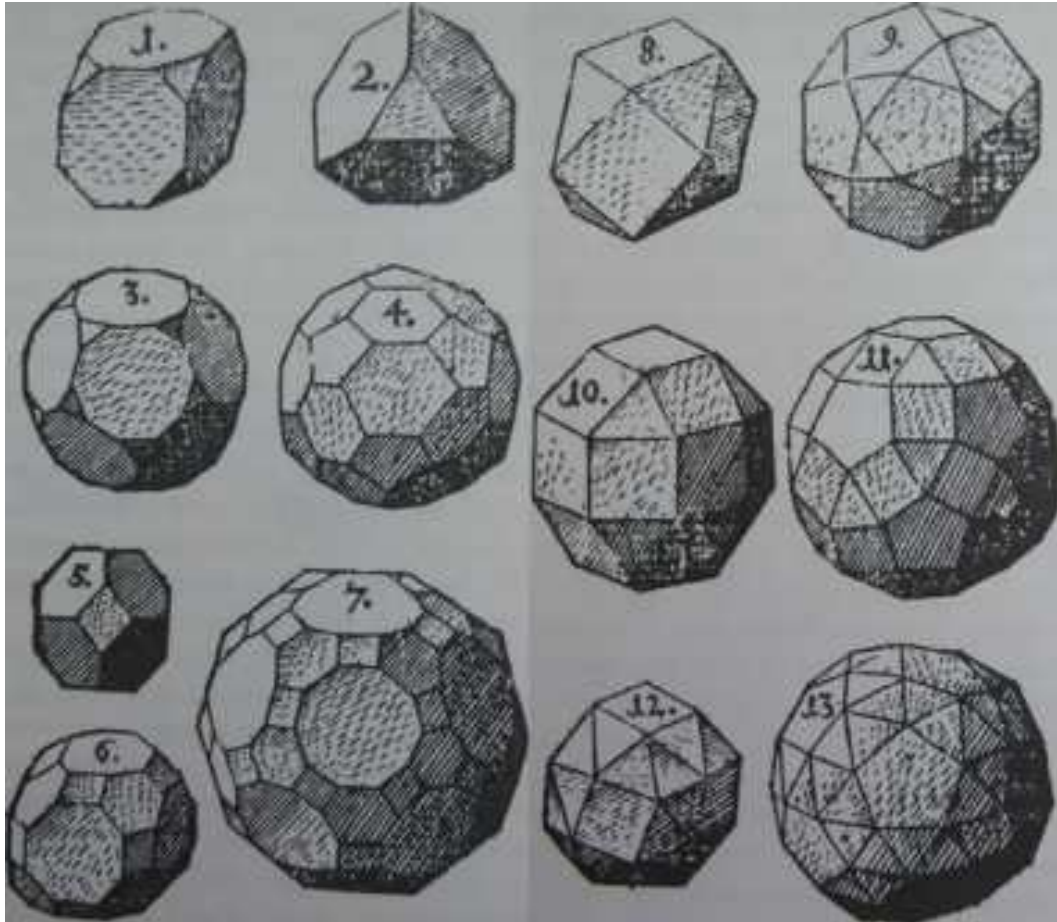

Figure 1.25: Thirteen Archimedean Solids

An Archimedean (semiregular) solid is a convex polyhedron composed of two or more regular polygons meeting in identical vertices. Nine of the thirteen Archimedean solids have some equilateral triangular faces (Figure 1.25): truncated cube (1), truncated tetrahedron (2), truncated dodecahedron (3), cuboctahedron (8), icosidodecahedron (9), (small) rhombicuboctahedron (10), (small) rhombicosidodecahedron (11), snub cube (12) and snub dodecahedron (13) [66]. Of the thirteen, only the truncated octahedron (5) can fill space. Archimedes' work on the semiregular solids has been lost to us and we only know of it through the later writings of Pappus.

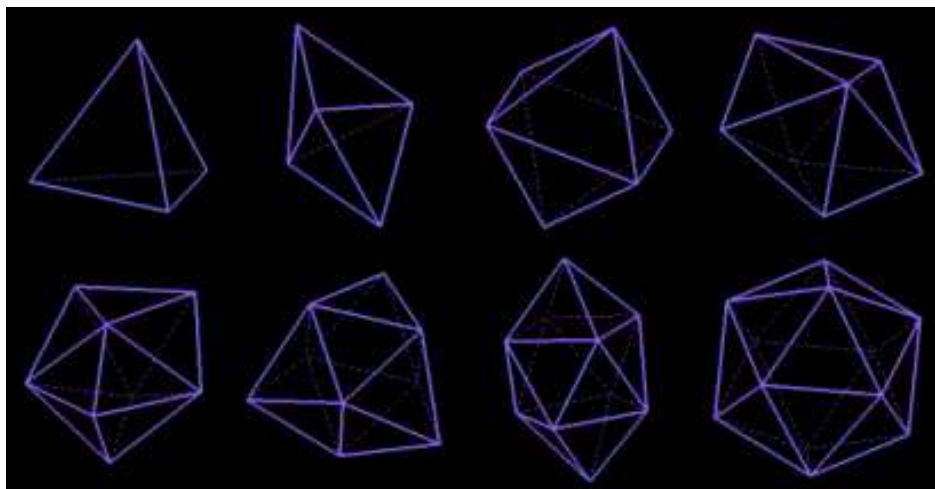

Figure 1.26: Eight Convex Deltahedra

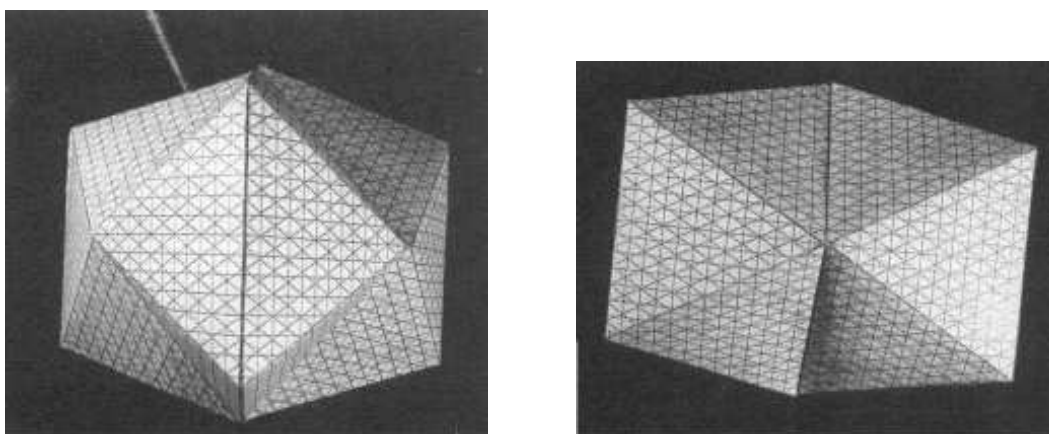

Figure 1.27: Two Views of Almost-Convex 18-Sided “Deceptahedron” [134]

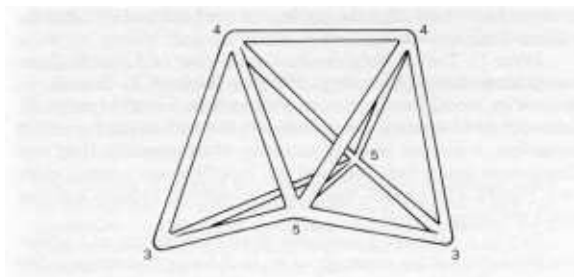

Figure 1.28: Non-Convex 8-Sided Deltahedron [134]

A deltahedron is a polyhedron whose faces are congruent non-coplanar equilateral triangles [322]. Although there are infinitely many deltahedra, Freudenthal and van der Waerden showed in 1947 that only eight of them are convex, having 4 (tetrahedron), 6 (triangular dipyramid), 8 (octahedron), 10 (pentagonal dipyramid), 12 (dodecadeltahedron), 14 (tetracaidecadeltahedron), 16 (heccaidecadeltahedron) and 20 (icosahedron) faces (Figure 1.26) [66]. These, together with the cube and dodecahedron, bring the number of convex polyhedra with congruent regular faces up to ten. The absence of an 18-sided convex deltahedron is most peculiar. Figure 1.27 displays two views of an 18-sided deltahedron due to E. Frost that is so close to being convex that W. McGovern has named it a “deceptahedron” [134]. In addition to the octahedron, there is the non-convex 8-sided deltahedron shown in Figure 1.28 [134]. Whereas the regular octahedron has four edges meeting at each of its six vertices, this solid possesses two vertices where three edges meet, two vertices where four edges meet and two vertices where five edges meet.

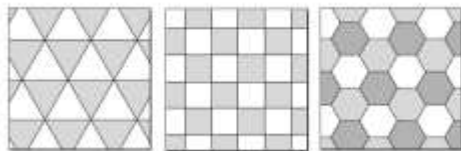

Figure 1.29: The Three Regular Tilings of the Plane

One of the three regular tilings of the plane is comprised of equilateral triangles (Figure 1.29). Six of the eight semiregular tilings of the plane have equilateral triangular components (Figure 1.30). Study of such tilings was inaugurated in the *Harmonice Mundi* of Johannes Kepler [156].

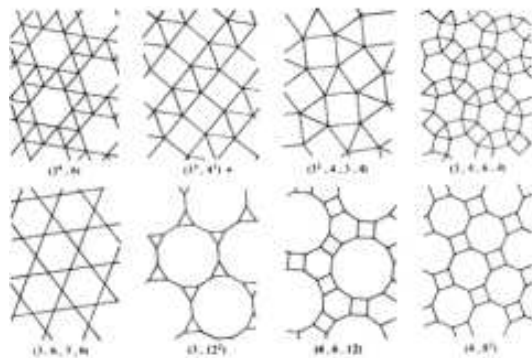

Figure 1.30: The Eight Semiregular Tilings of the Plane

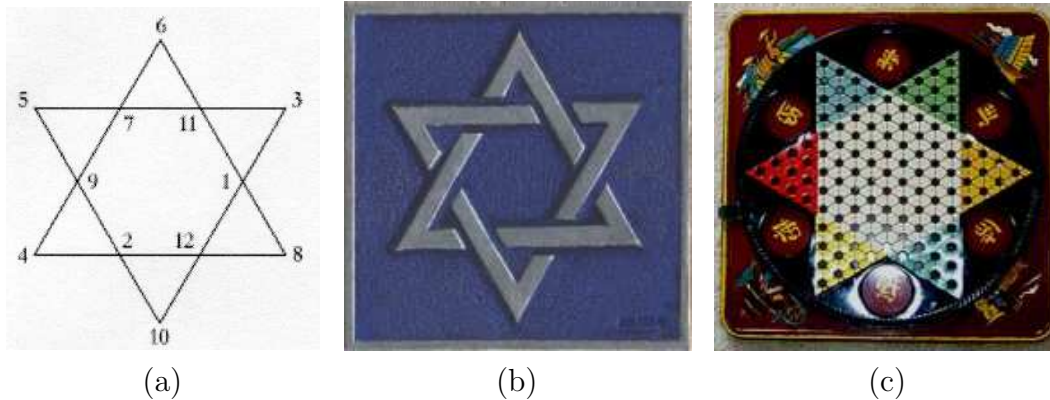

Figure 1.31: Hexagram: (a) Magic Hexagram. (b) Star of David. (c) Chinese Checkers

A hexagram is a six-pointed star, with a regular hexagon at its center, formed by combining two equilateral triangles (Figure 1.31). Throughout the ages and across cultures, it has been one of the most potent symbols used in magic [49]. The yantra of Vishnu, the Supreme God of the Vishnavite tradition of Hinduism, contains such a hexagram [193]. Mathematically, a normal magic hexgram (Figure 1.31(a)) arranges the first 12 positive integers at the vertices and intersections in such a way that the four numbers on each line sum to the magic constant $M = 26$ [87, p. 145]. This can be generalized to a normal magic star which is an n -pointed star with an arrangement of the consecutive integers 1 thru $2n$ summing to a magic number of $M = 4n + 2$ [308].

The Star of David (Figure 1.31(b)) is today generally recognized as a symbol of Jewish identity. It is identified with the Shield of David in Kabbalah, the school of thought associated with the mystical aspect of Rabbinic Judaism. Named after King David of ancient Israel, it first became associated with the Jews in the 17th Century when the Jewish quarter of Vienna was formally distinguished from the rest of the city by a boundary stone having a hexagram on one side and a cross on the other. After the Dreyfus affair in 19th Century France, it became internationally associated with the Zionist movement. With the establishment of the State of Israel in 1948, the Star of David became emblazoned on the Flag of Israel [278].

Figure 1.31(c) contains the playing board for the inappropriately named Chinese Checkers. The game was invented not in ancient China but in Germany by Ravensburger in 1893 under the name “Stern-Halma” as a variation of the older American game of Halma. “Stern” is German for star and refers to the star-shaped board in contrast to the square board of Halma. In the United States, J. Pressman & Co. marketed the game as “Hop Ching Checkers” in 1928 but quickly changed the name to “Chinese Checkers” as it gained popularity. This was subsequently introduced to China by the Japanese [236].

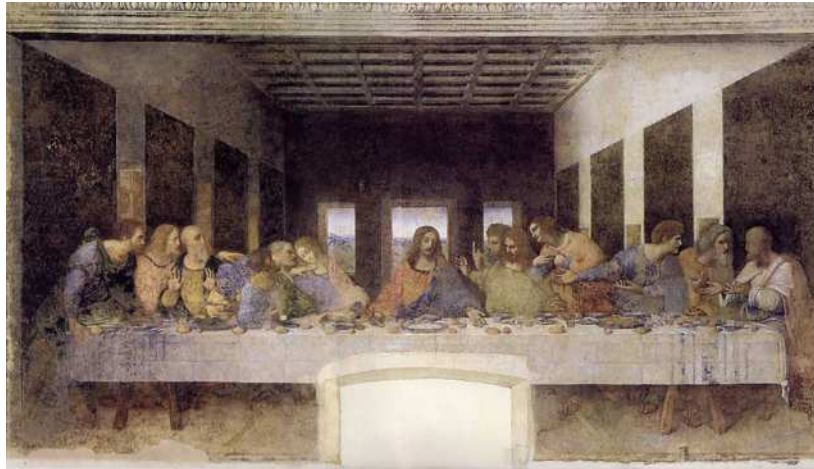

Figure 1.32: *The Last Supper* (Da Vinci: 1498)



Figure 1.33: *Supper at Emmaus* (Pontormo: 1525)



Figure 1.34: *Christ of Saint John of the Cross* (Dali: 1951)

The equilateral triangle is a recurring motif in Christian Art [222]. Front and center in this genre is occupied by Leonardo da Vinci's *The Last Supper* (see Figure 1.32). Begun in 1495 and finished in 1498, it was painted on the rear wall of the Refectory at the Convent of Santa Maria delle Grazie. This mural began to deteriorate in Leonardo's own lifetime. Its most recent restoration took twenty years and was only completed in 1999. In this great masterpiece, the body of Jesus is a nearly perfect equilateral triangle symbolizing the Trinity. The serene calm of this sacred figure anchors the utter chaos which has been unleashed by His announcement of the upcoming betrayal by one of the attending apostles. The theme of Trinity is further underscored by Leonardo's partitioning of the apostles into four groups of threes.

The role of the equilateral triangle is even more explicit in Jacopo Pontormo's 1525 painting *Supper at Emmaus* (see Figure 1.33). Not only is the figure of Jesus an equilateral triangle but a radiant triangle with a single eye hovers above Christ's head. This symbolizes the all-seeing Eye of God with the triangle itself representing the Holy Trinity of God the Father, God the Son and God the Holy Spirit. This painting portrays the occasion of the first appearance of Christ to two disciples after His Resurrection.

In Salvador Dali's 1951 *Christ of Saint John of the Cross* (see Figure 1.34), the hands and feet of Our Lord form an equilateral triangle symbolizing Father, Son and Holy Spirit. It depicts Jesus Christ on the cross in a darkened sky floating over a body of water complete with a boat and fishermen. It is devoid of nails, blood and crown of thorns because Dali was convinced by a dream that these features would mar his depiction of the Saviour. This same dream suggested the extreme angle of view as that of the Father. The name of the painting derives from its basis in a drawing by the 16th Century Spanish friar Saint John of the Cross.

The equilateral triangle was frequently used in Gothic architectural design [30]. Figure 1.35 presents a transversal section of the elevation of the Cathedral (Duomo) of Milan drawn by Caesare Cesariano and published in his 1521 Italian translation of Vitruvius' *De Architectura*. Cesariano was a student of da Vinci and one of the many architects who produced designs for the Milan Cathedral over the nearly six centuries of its construction from 1386 to 1965. Even though this design was ultimately abandoned, it is significant in that it is one of the rare extant plans for a Gothic cathedral. It clearly shows the application of *ad triangulum* design which employs a lattice of equilateral triangles to control placement of key features and proportions of components. This technique is combined with one utilizing a system of concentric circles [285]. It is clear that the equilateral triangle was an important, although by no means the only, geometric design element employed in the the construction of the great Gothic cathedrals. This *ad triangulum* design principle was adopted by Renaissance artists, particularly in their sacred paintings.

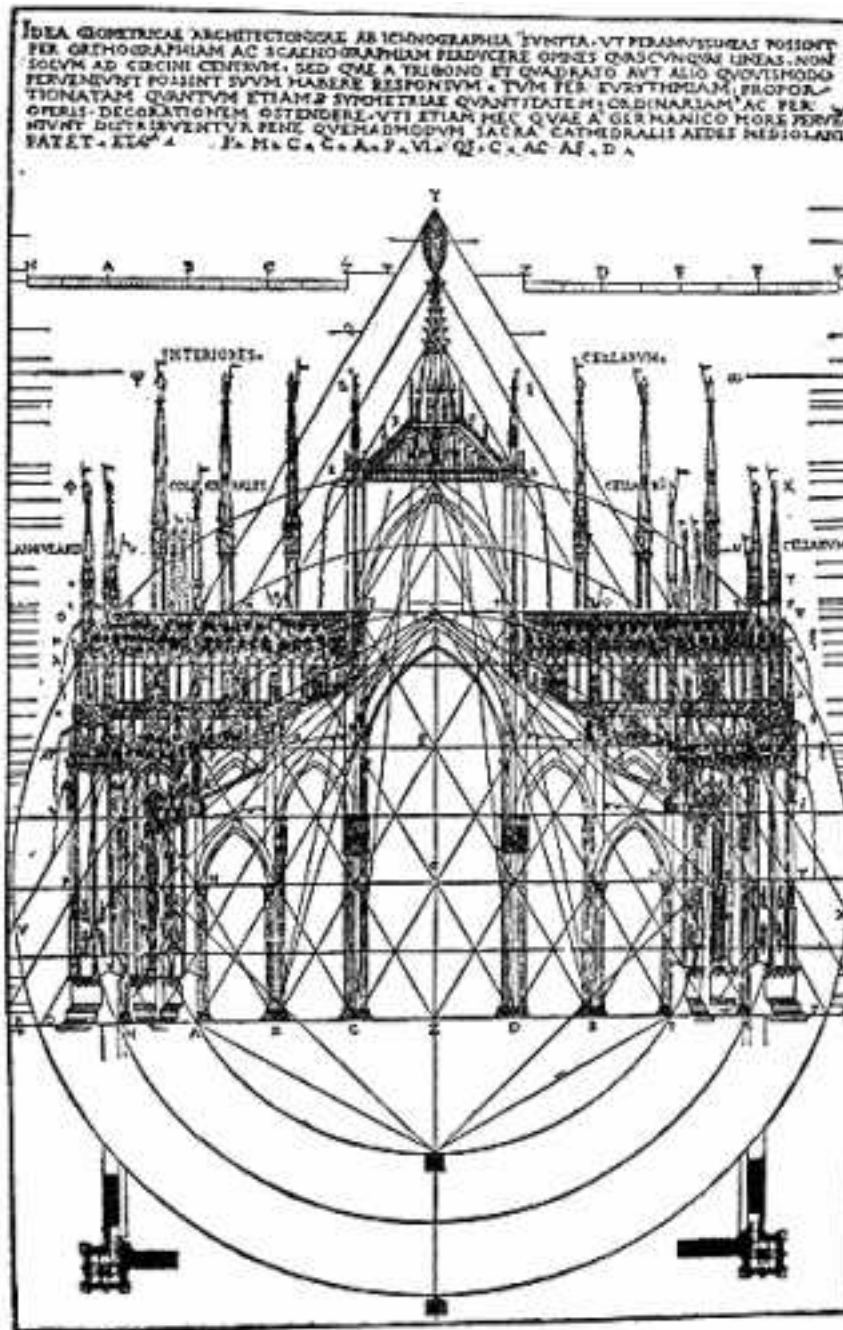

Figure 1.35: Milan Cathedral (Caesariano: 1521) [142]

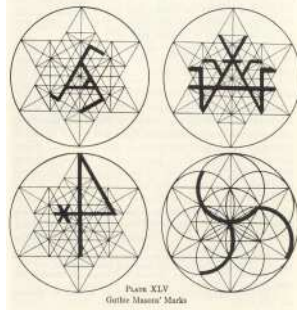

Figure 1.36: Gothic Mason's Marks [142]

In the Gothic Masons Guilds [142], the Companion (second degree of initiation) received a personal mason's mark at the end of his probationary period. This seal, which would be his sign or password for the remainder of his life, was not secret and would be used to identify his work and to gain admission when visiting other lodges. Many of the mason's marks used by these master builders to identify themselves and their work were based upon the equilateral triangle [142, pp. 119-123] (Figure 1.36).



Figure 1.37: Heraldic Cross of the Knights Templar

The Order of the Temple (The Knights Templar) was organized in France at the commencement of the First Crusade in 1096 A.D. [15]. They trained like modern day commandos and battled to the death. The Knights Templar battled like demons for hundreds of years throughout the various Crusades, meeting their end at Acre, their last stronghold in the Holy Lands, in 1291. Most of them were butchered by the Moslems and the survivors made their way to France where their Order was eventually suppressed by the Catholic Church. The remaining Knights Templar became affiliated with Freemasonry. The Heraldic Cross of the Knights Templar (a.k.a. cross formée, Tatzenkreuz, Iron cross, Maltese cross, Victoria cross) is comprised of an arrangement of four equilateral triangles joined at a common vertex (Figure 1.37).



Figure 1.38: Masonic Royal Arch Jewel

Freemasonry is a fraternal organization that arose in the late 16th to early 17th Centuries [174]. Freemasonry uses metaphors of stonemasons' tools and implements to convey a system of beliefs based upon charitable work, moral uprightness and fraternal friendship. It has been described as a “society with secrets” rather than a secret society. The private aspects of Freemasonry concern the modes of recognition amongst members and particular elements within their rituals. Both Wolfgang Amadeus Mozart and George Washington were prominent Freemasons and Masonic Lodges still exist today. The equilateral triangle is used in Freemasonry as the symbol of the Grand Architect of the Universe [29] (Figure 1.38).



Figure 1.39: Rosicrucian Cross

Rosicrucianism (The Brotherhood of the Rosy Cross), on the other hand, was a truly secret society which arose roughly contemporaneously in Germany in the early 17th Century [50]. At times referred to as the College of Invisibles, this secret brotherhood of alchemists and sages sought to transform the arts, sciences, religion, and political and intellectual landscape of Europe. It is believed likely that both Kepler and Descartes were Rosicrucians [3]. There are several modern day groups that have styled themselves after the Rosicrucians. The equilateral triangle is also used in the symbolism of the Rosicrucians (Figure 1.39).



Figure 1.40: Vesica Piscis

The *vesica piscis* (“fish’s bladder”) [204] (Figure 1.40) was the central diagram of Sacred Geometry for the Christian mysticism of the Middle Ages. It was the major thematic source for the Gothic cathedrals such as that at Chartres. Renaissance artists frequently surrounded images of Jesus and framed depictions of the Virgin Mary with it [285]. Its intimate connection with $\sqrt{3}$ is revealed by the presence of the equilateral triangles in Figure 1.40. It in fact predates Christianity [170] and is known in India as *mandorla* (“almond”). It was used in early Mesopotamia, Africa and Asia as a symbol of fertility. To the Pythagoreans, it symbolized the passage of birth. Figure 1.41 shows the image of Jesus Christ enclosed in a vesica piscis from a medieval illuminated manuscript. Such images allude to his life as a “fisher of men”.



Figure 1.41: Jesus Christ

Utilizing a vesica piscis and a large triangle within it that is further subdivided, Figure 1.42 reveals the tripartite structure of many naturally occurring objects [271].

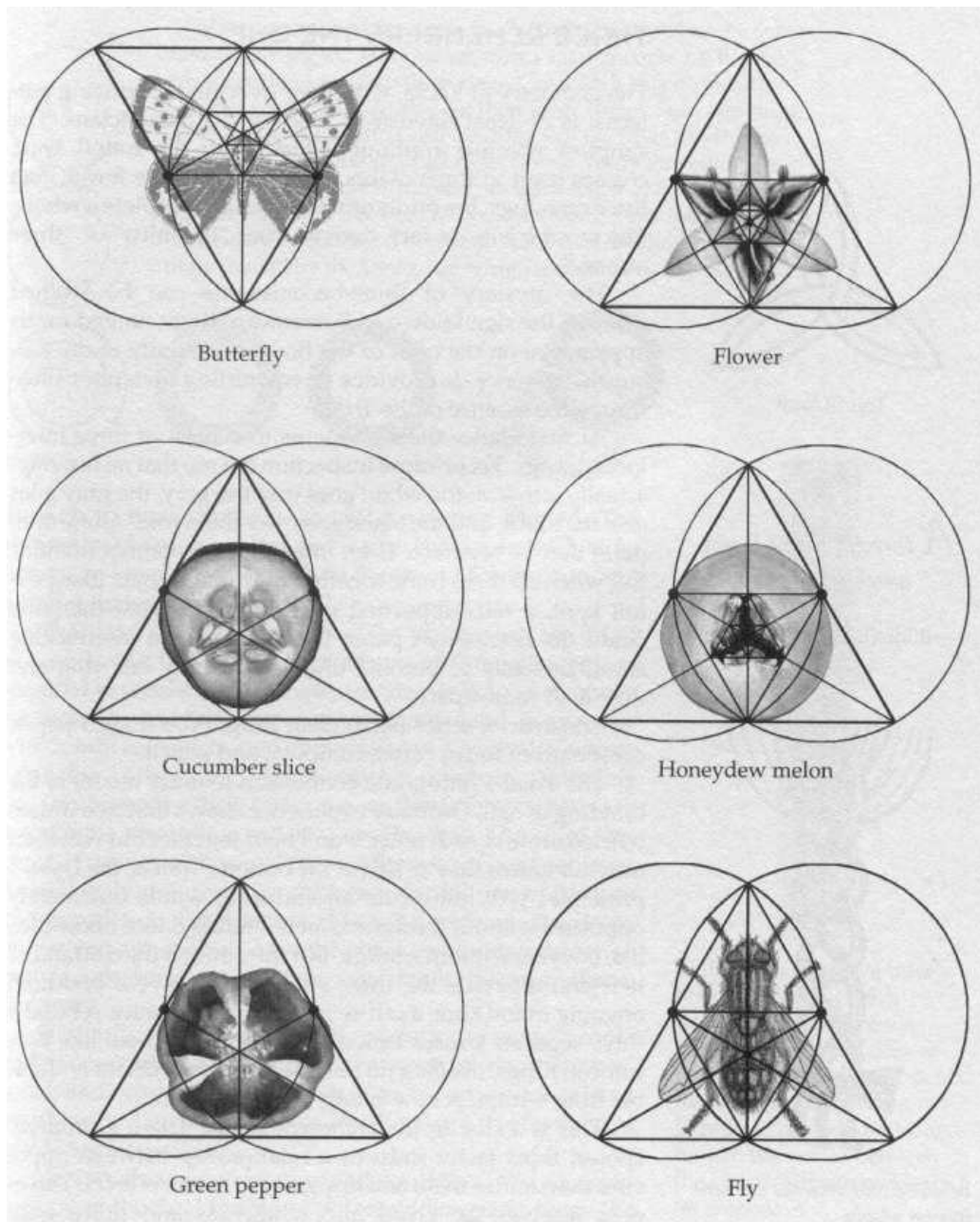

Figure 1.42: Three-Part Harmony [271]



Figure 1.43: Alchemical Symbols

Alchemy is an ancient practice concerned with changing base metals into gold, prolonging life and achieving ultimate wisdom. In particular, alchemy is the predecessor of modern inorganic chemistry [154]. Alchemy has been widely practiced for at least 5,000 years in ancient Egypt, Mesopotamia, India, Persia, China, Japan, Korea, the classical Greco-Roman world, the medieval Islamic world, and medieval Europe up to the 17th Century. (Isaac Newton devoted considerably more of his writing to alchemy than to physics and Mathematics combined! [328]) The alchemical symbols for the four elements (Earth, Wind, Air and Fire) are all composed of equilateral triangles (Figure 1.43).



Figure 1.44: Scientology Symbol

Fascination with the equilateral triangle persists to this day. The Church of Scientology [207] was founded by science fiction author L. Ron Hubbard in 1953 based upon his principles of Dianetics [187]. It counts among its adherents the movie stars John Travolta and Tom Cruise as well as the musicians Chick Corea and Edgar Winter. The Scientology Symbol is the letter *S* together with two equilateral triangles (Figure 1.44). The upper (KRC) triangle symbolizes knowledge, responsibility and control while the lower (ARC) triangle symbolizes affinity, reality and communication.

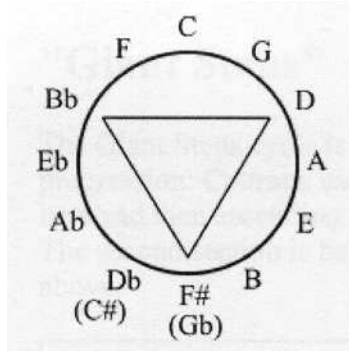

Figure 1.45: Augmented Triad [218]

An equilateral triangle on the circle-of-fifths [218] produces a musical chord known as an augmented triad (Figure 1.45). Unlike other kinds of triads, such as major, minor and diminished, it does not naturally arise in a diatonic scale. However, the augmented triad does occur in the tonal music of Classical composers such as Haydn, Beethoven and Brahms. The augmented triad has also been used by Romantic composers such as Liszt and Wagner to suspend tonality. Schubert led the way in organizing many pieces, such as his *Wanderer Fantasy*, by descending major thirds which is the component interval of the augmented triad. Jazz musicians, such as Miles Davis and John Coltrane, have freely used chord progressions utilizing downward root movement by major thirds as a substitute for the traditional $ii - V - I$ progression.



(a)



(b)

Figure 1.46: Equilateral Triangular Sculpture: (a) *Intuition* by J. Robinson. (b) H. S. M. Coxeter holding a model of G. Odom's *4-Triangle Sculpture*. [61].

Modern sculpture has not been immune to the influence of the equilateral triangle. A *hollow triangle* is defined as the planar region between two homothetic and concentric equilateral triangles, i.e. a flat triangular ring [61].

Intuition by Australian sculptor John Robinson (Figure 1.46(a)) is composed of three such triangular rings forming a structure in which certain points on two outer edges of each ring fit into two inner corners of the next, in cyclic order. The topology of the assembly is that of the “Borromean rings” (all three triangles are linked, but no pair is linked), and its symmetry group is C_3 , cyclically permuting the three hollow triangles. H. Burgiel et al. [37] have shown that, for the structure to be realizable in three dimensions, the ratio of the edge length of the outer triangle to the inner triangle must lie strictly between one and two. In fact, Robinson utilized a ratio of $(2\sqrt{6}+1)/3 \approx 1.966$.

Independently, American artist George Odom assembled four such triangular rings (with edge ratio 2:1) to form a rigid structure in which the midpoints of the three outer edges of each ring fit into inner corners of the three remaining rings (Figure 1.46(b)). The four rings are mutually interlocked and the symmetry group is the octahedral group O or S_4 : 24 rotations permuting the 4 hollow triangles in all of the $4!$ possible ways.



Figure 1.47: Gateway Arch

As an example of the equilateral triangle in contemporary architecture, consider the Gateway Arch shown in Figure 1.47. (For other examples see the *Gallery of Equilateral Triangles* in Appendix A.) It is part of the Jefferson National Expansion Memorial on the Saint Louis riverfront. Each leg is an equilateral triangle with sides 54 feet long at ground level and tapering to 17 feet at the top. The stainless-steel-faced Arch spans 630 feet between the outer faces of its equilateral triangular legs at ground level and its top

soars 630 feet into the sky. The interior of the Arch is hollow and contains a tram transport system leading to an observation deck at the top. This is complemented by two emergency stairwells of 1076 steps each. The Arch has no real structural skeleton. Its inner and outer steel skins are joined to form a composite structure which provides its strength and permanence.



Figure 1.48: *Star Trek*: (a) Planet Triskelion in Trinary Star System M_{24_α} . (b) Triskelion Battlefield. (c) Kirk confronts the Providers.

Pop culture has also felt the sway of the equilateral triangle. In the 1960's cult classic *Star Trek*, the 1968 episode *The Gamesters of Triskelion* (Figure 1.48) sees Captain Kirk, Lieutenant Uhura and Ensign Chekov beamed to the planet Triskelion which orbits one of a trinary star system (a). There they must do battle with combatants kidnapped from other worlds on a hexagonal battlefield with three spiral arms surrounding a central equilateral triangle (b); all this to satisfy the yearn for wagering of the three disembodied Providers who rule Triskelion from their equilateral triangular perch (c).

In the 1990's science fiction epic *Babylon 5*, the Triluminary was a crystal shaped as an equilateral triangle with a small chip at its center. The holiest of relics in Minbari society, it was a multifaceted device. Its primary function was to glow in the presence of the DNA of the Minbari prophet Valen. Its use brought the Earth-Minbari War to an end when it indicated that Commander Jeffrey Sinclair of Earth had Valen's DNA and thus a Minbari soul thereby prompting a Minbari surrender. (Unlike Humans, Minbari do not kill Minbari!) A Triluminary (there were three of them in existence) was also used to induct a new member into the ruling Grey Council of Minbar. As shown in Figure 1.49(a), Minbari Ambassador Delenn uses a Triluminary as part of a device which transforms her into a Human-Minbari hybrid in order to foster mutual understanding between the two races. The Triluminary is emblematic of the Minbari belief in the Trinity. As Zathras (caretaker of the Great Machine on Epsilon III) explains to Sinclair, Delenn and Captain John Sheridan: three castes, three languages, the Nine of the Grey Council (three times three), "All is three, as you are three, as you are one, as you are the One". Sinclair then travels back in time one thousand years, uses the Triluminary (Figure 1.49(b))

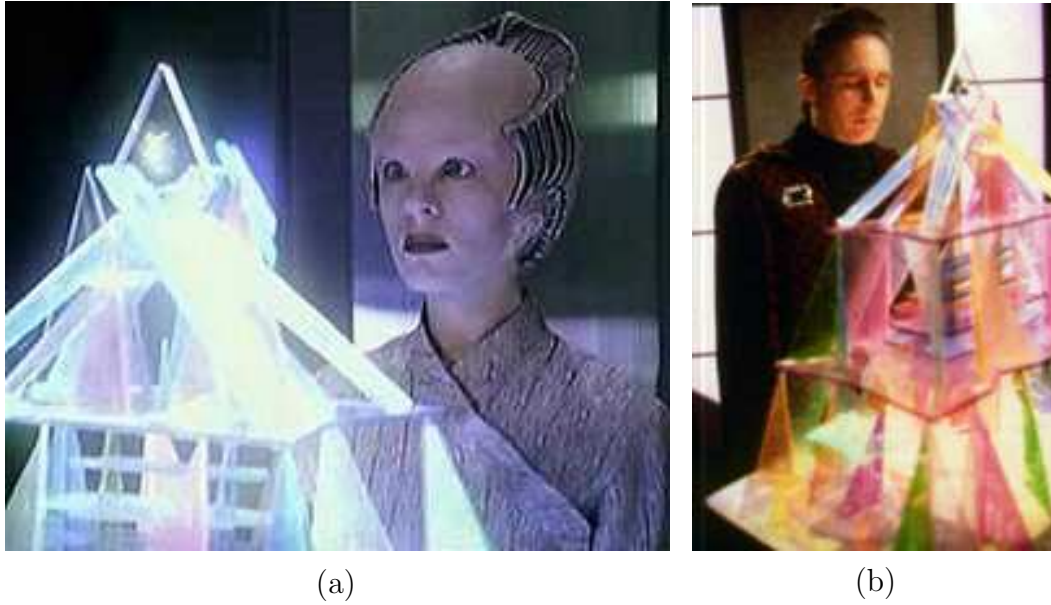

Figure 1.49: Triluminary (*Babylon 5*): (a) Delenn. (b) Sinclair.

to become Valen (“a Minbari not born of Minbari”), and leads the forces of Light to victory over the Shadows.



Figure 1.50: Symbol of the Deathly Hallows (*Harry Potter*)

Figure 1.50 displays the symbol of the Deathly Hallows (composed of an equilateral triangle together with incircle and altitude) from the book/film *Harry Potter and the Deathly Hallows* which represents three magical items: the Elder Wand, the Resurrection Stone and the Cloak of Invisibility. He who unites the Hallows is thereby granted the power to elude Death.

In retrospect, one is struck by the universal appeal of the equilateral triangle. Its appearances date back to the beginnings of recorded history and interest in it has transcended cultural boundaries. Since the equilateral triangle may be studied using only the rudiments of Mathematics, there is a certain temptation to dismiss it as mathematically trivial. However, there are aspects of the equilateral triangle that are both mathematically deep and stunningly beautiful. Let us now explore some of the many facets of this glistening jewel!

Chapter 2

Mathematical Properties of the Equilateral Triangle

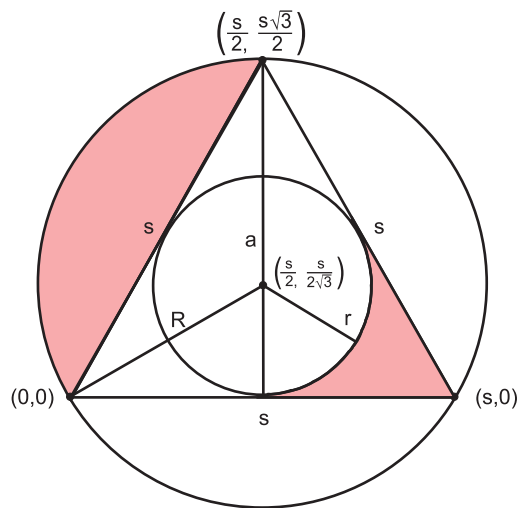

Figure 2.1: Equilateral Triangle and Friends

Property 1 (Basic Properties). *Given an equilateral triangle of side s :*

perimeter (p)	$3s$
altitude (a)	$s\frac{\sqrt{3}}{2}$
area (A)	$s^2\frac{\sqrt{3}}{4}$
inradius (r)	$s\frac{\sqrt{3}}{6}$
circumradius (R)	$s\frac{\sqrt{3}}{3}$
incircle area (A_r)	$s^2\frac{\pi}{12}$
circumcircle area (A_R)	$s^2\frac{\pi}{3}$

The relation $R = 2r$, which is a consequence of the coincidence of the circumcenter (intersection of perpendicular bisectors) and the incenter (intersection of angle bisectors) with the centroid (intersection of medians which trisect one another), is but an outer manifestation of the hidden inner relations of Figure 2.1. It immediately implies that the area of the annular region between the circumcircle and the incircle is three times the area of the latter. In turn, this leads directly to the beautiful relation that the sum of the shaded areas equals the area of the incircle!

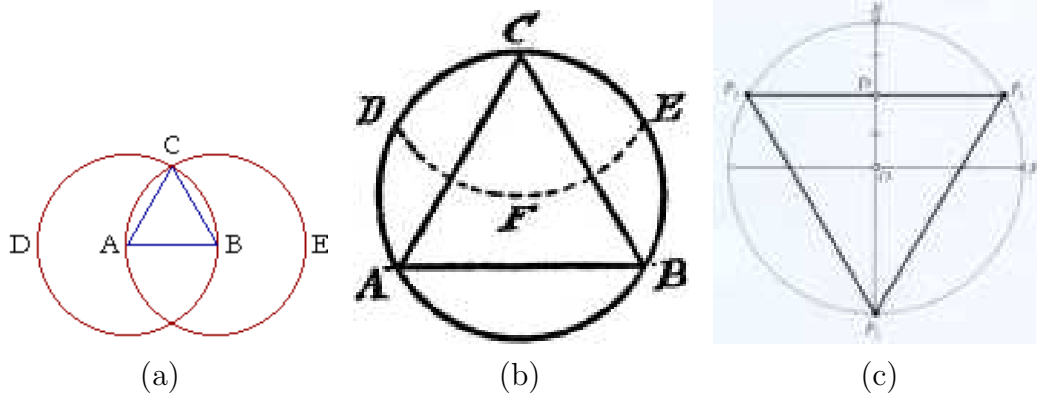

Figure 2.2: Construction of Equilateral Triangle: (a) Euclid [164]. (b) Hopkins [185]. (c) Weisstein [320].

Property 2 (Construction of Equilateral Triangle). *An equilateral may be constructed with straightedge and compass in at least three ways.*

1. Figure 2.2(a): Let AB be a given line segment. With center A and radius AB , construct circle BCD . With center B and radius BA , construct circle ACE . From their point of intersection C , draw line segments CA and CB . $\triangle ABC$ is equilateral [164].
2. Figure 2.2(b): Given a circle with center F and radius FC , draw the arc DFE with center C and radius CF . With the same radius, and D and E as centers, set off points A and B . $\triangle ABC$ is equilateral [185].
3. Figure 2.2(c): Draw a diameter OP_0 of a circle and construct its perpendicular bisector P_3OB ; bisect OB in point D and extend the line P_1P_2 through D and parallel to OP_0 . $\triangle P_1P_2P_3$ is then equilateral [320].

Property 3 (Rusty Compass Construction). *Some compasses are rusty, so that their opening cannot be changed. Given such a rusty compass whose opening is at least half the given side length AB (so that the constructed circles intersect), it is possible to extend the Euclidean construction to a corresponding five-circle construction [237].*

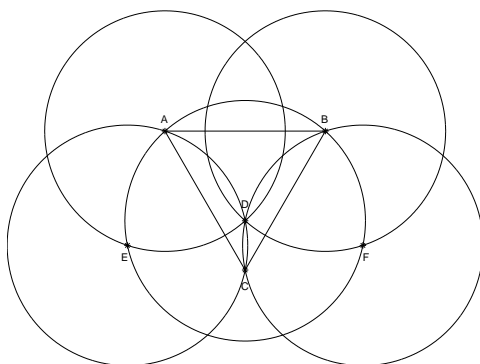

Figure 2.3: Five-Circle Rusty Compass Construction

All five circles in Figure 2.3 have the same radius. The first two are centered at the given points A and B . These two circles intersect at two points. Call one of them D and make it the center of a third circle which intersects the first two circles at two new points E and F (in addition to A and B) which again serve as centers of two additional circles. These last two circles intersect at D and one additional point, C . $\triangle ABC$ is equilateral. This follows since the central angle BFD is, by construction, equal to 60° , so that the inscribed angle BCD is equal to half of that, or 30° . The same is true of angle ACD , so that angle BCA is equal to 60° . By symmetry, triangle ABC is isosceles ($AC = BC$) thereby making $\triangle ABC$ equilateral. According to Pedoe [237, p. xxxvi], a student stumbled upon this construction while idly doodling in class, yet it has generated considerable research in rusty compass constructions.

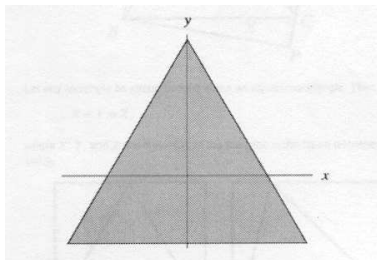

Figure 2.4: Equation of Equilateral Triangle [320]

Property 4 (Equation of Equilateral Triangle). *An equation for an equilateral triangle with $R = 1$ ($s = \sqrt{3}$) (Figure 2.4) [320]:*

$$\max(-2y, y - x\sqrt{3}, y + x\sqrt{3}) = 1.$$

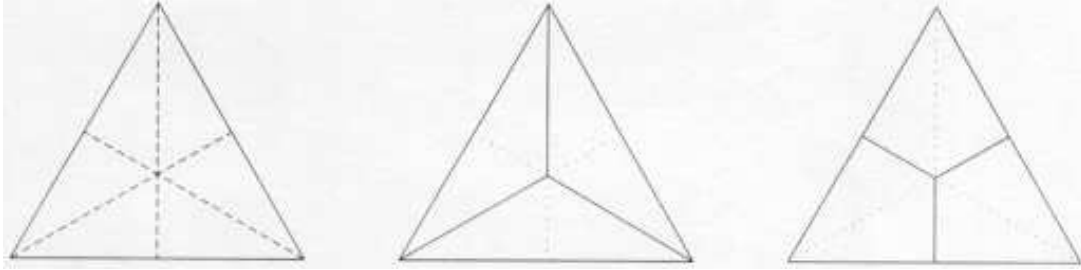

Figure 2.5: Trisection Through Bisection

Property 5 (Trisection Through Bisection). *In an equilateral triangle, the altitudes, angle bisectors, perpendicular bisectors and medians coincide.*

These three bisectors provide the only way to divide an equilateral triangle into two congruent pieces using a straight-line cut (Figure 2.5 left). Interestingly, these very same bisectors, suitably constrained, also provide the only two trisections of the equilateral triangle into congruent pieces using just straight-line cuts (Figure 2.5 center and right).

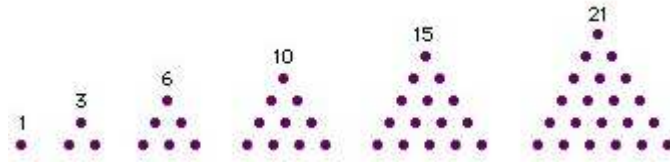

Figure 2.6: Triangular Numbers

Property 6 (Triangular Numbers). *The first six triangular numbers are on display in Figure 2.6. They are defined as:*

$$\Delta_n = \sum_{k=1}^n k = \frac{n(n+1)}{2} = \binom{n+1}{2}.$$

As such, Δ_n solves the “handshake problem” of counting the number of handshakes in a room full of $n + 1$ people if each person shakes hands once with each other person. They are closely related to other figurate numbers [55]. For example, the sum of two consecutive triangular numbers is a square number with the sum being the square of their difference:

$$\Delta_n + \Delta_{n-1} = 1 + 3 + 5 + \cdots + (2n - 1) = n^2 = (\Delta_n - \Delta_{n-1})^2.$$

Also, the sum of the first n triangular numbers is the n th tetrahedral number:

$$\sum_{k=1}^n \Delta_k = \frac{n(n+1)(n+2)}{6}.$$

The triangular numbers are also subject to many beautiful recurrence relations such as:

$$\Delta_n^2 + \Delta_{n-1}^2 = \Delta_{n^2}, \quad 3\Delta_n + \Delta_{n-1} = \Delta_{2n}, \quad 3\Delta_n + \Delta_{n+1} = \Delta_{2n+1}, \quad \Delta_{n+1}^2 - \Delta_n^2 = (n+1)^3.$$

Finally, the triangular number $\Delta_n = n + (n - 1) + \dots + 2 + 1$ is the additive analog of the multiplicative factorial $n! = n \cdot (n - 1) \cdot \dots \cdot 2 \cdot 1$ [320].

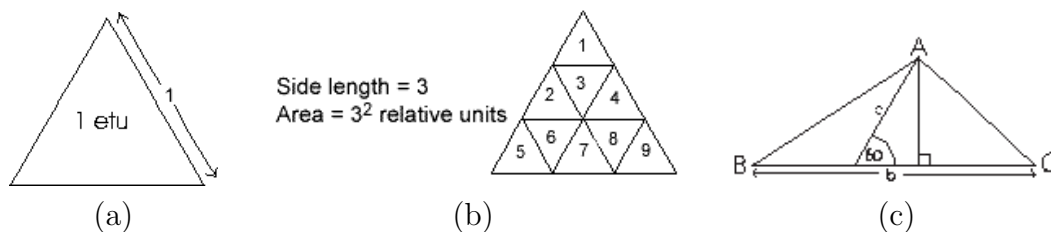

Figure 2.7: Equitriangular Unit of Area: (a) ETU. (b) Equilateral Area. (c) Scalene Area. [255]

Property 7 (Equitriangular Unit of Area). *Motivated by the identity $\Delta_n + \Delta_{n-1} = n^2$, W. Roberts has introduced [255] the equitriangular unit of area (etu) shown in Figure 2.7(a).*

Naturally, the area of an equilateral triangle of side n is then equal to n^2 etu, as seen in Figure 2.7(b). Referring to Figure 2.7(c), the area of a scalene triangle is simply ab etu where a is the 60° altitude of the vertex above base b .

Property 8 (Viviani’s Theorem). *For any point inside an equilateral triangle, the sum of the distances to the sides is equal to the height of the triangle. (Figure 2.8: $PE + PF + PG = h$.)*

The same is true if the point lies outside the triangle so long as signed distances are employed [322]. Conversely, if inside a triangle there is a circular region in which the sum of the distances from any point to the sides of the triangle is constant then the triangle is equilateral [48].

Property 9 (Ternary Diagram). *Viviani’s Theorem implies that lines parallel to the sides of an equilateral triangle provide (homogeneous/barycentric/areal/trilinear) coordinates [275] for ternary diagrams for representing three quantities A, B, C whose sum is a constant (which can be normalized to unity).*

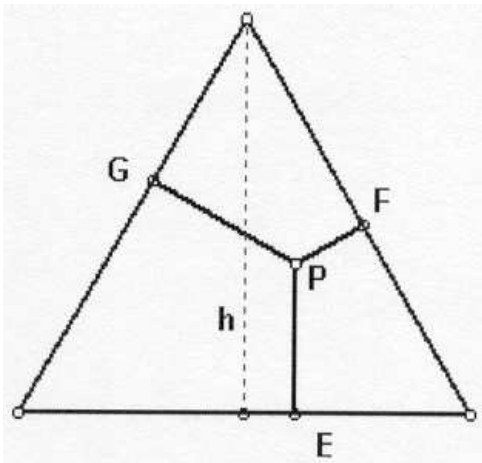

Figure 2.8: Viviani's Theorem

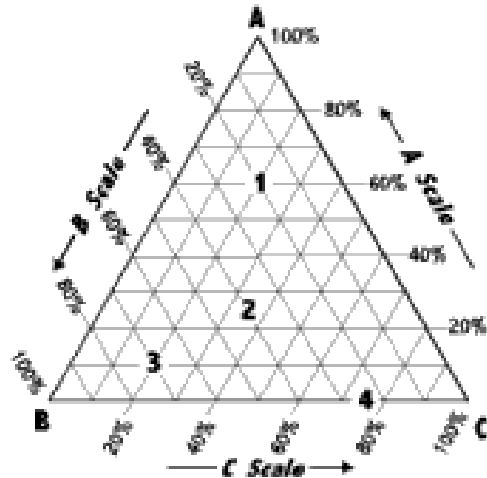

Figure 2.9: Ternary Diagram

With reference to Figure 2.9, each variable is assigned to a vertex as well as to the clockwise-adjacent edge. These diagrams are employed in petrology, mineralogy, metallurgy and other physical sciences to portray the composition of systems composed of three species. In population genetics, it is called the de Finetti diagram and, in game theory, it is called the simplex plot. Ample specific instances will be provided in Chapter 3: *Applications*.

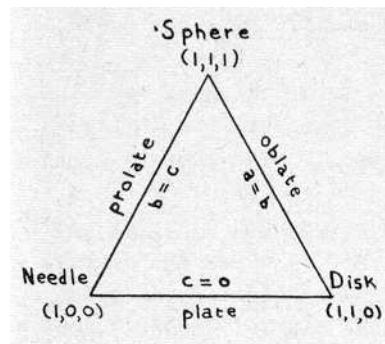

Figure 2.10: Ellipsoidal Shape [243]

Property 10 (Ellipsoidal Shape). *The shape of an ellipsoid with semi-axes a , b and c depends only on the ratios $a : b : c$. In order to visualize the variety of these shapes, we may consider a , b and c as homogeneous coordinates ([256, pp. 16-20], [257, pp. 179-190]) of a point (a, b, c) in a plane and consider only that part of this plane where $a \geq b \geq c \geq 0$. These inequalities delimit a triangle which can be made equilateral by a suitable choice of coordinate system (Figure 2.10) [243, p. 37].*

The points of this triangle are in one-to-one correspondence with the different ellipsoidal shapes. The interior points correspond to non-degenerate ellipsoids with three different axes, the boundary points to ellipsoids of revolution or to degenerate ellipsoids. The three vertices represent the sphere, the circular disk and the “needle” (segment of a straight line), respectively.

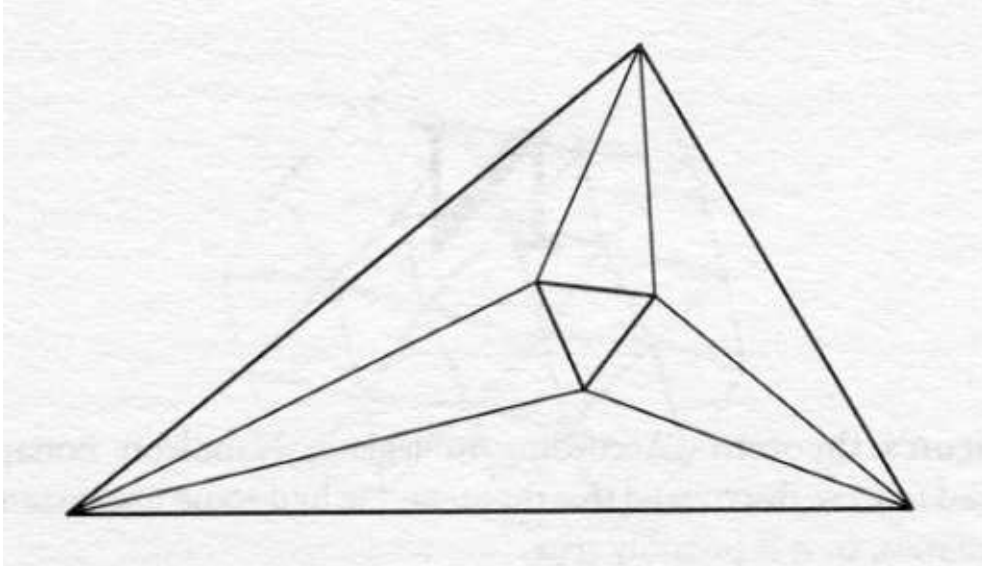

Figure 2.11: Morley's Theorem

Property 11 (Morley's Theorem). *The adjacent pairs of the trisectors of the interior angles of a triangle always meet at the vertices of an equilateral triangle [178] called the first Morley triangle (Figure 2.11).*

If, instead, the exterior angle trisectors are used then another equilateral triangle is formed (the second Morley triangle) and, moreover, the intersections of the sides of this triangle with the external trisectors form three additional equilateral triangles [322].

Property 12 (Fermat-Torricelli Problem). *In 1629, Fermat challenged Torricelli to find a point whose total sum of distances from the vertices of a triangle is a minimum [224]. I.e., determine a point X (Fermat point) in a given triangle ABC such that the sum $XA + XB + XC$ is a minimum [178].*

If the angle at one vertex is greater than or equal to 120° then the Fermat point coincides with this vertex. Otherwise, the Fermat point coincides with the so-called (inner) isogonic center (X in Figure 2.12) which may be found by constructing outward pointing equilateral triangles on the sides of $\triangle ABC$ and

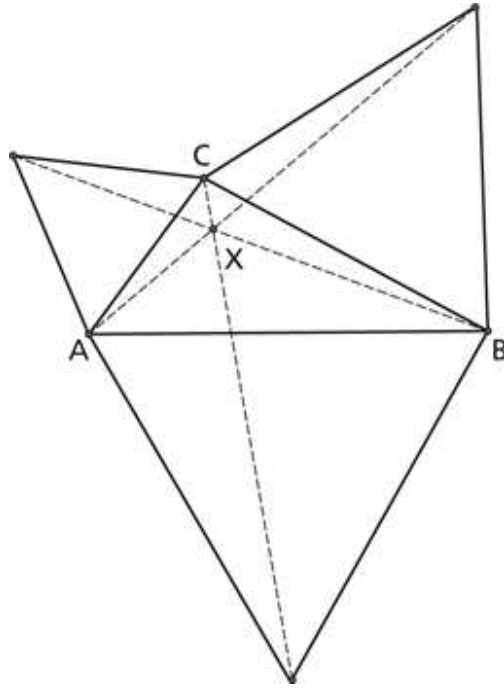

Figure 2.12: Fermat Point

connecting each vertex of the original triangle to the new vertex of the opposite equilateral triangle. These three segments are of equal length and intersect at the isogonic center where they are inclined at 60° to one another. At the isogonic center, each side of the original triangle subtends an angle of 120° . Also, the isogonic center lies at the common intersection of the circumcircles of the three equilateral triangles [322]. The algebraic sum of the distances from the isogonic center to the vertices of the triangle equals the length of the equal segments from the latter to the opposite vertices of the equilateral triangles [189].

Property 13 (Largest Circumscribed Equilateral Triangle). *If we connect the isogonic center of an arbitrary triangle with its vertices and draw lines through the latter perpendicular to the connectors then these lines intersect to form the largest equilateral triangle circumscribing the given triangle [189]. This is the antipedal triangle of the isogonic center with respect to the given triangle.*

Property 14 (Napoleon's Theorem). *On each side of an arbitrary triangle, construct an equilateral triangle pointing outwards. The centers of these three triangles form an equilateral triangle [178] called the outer Napoleon triangle (Figure 2.13(a)).*

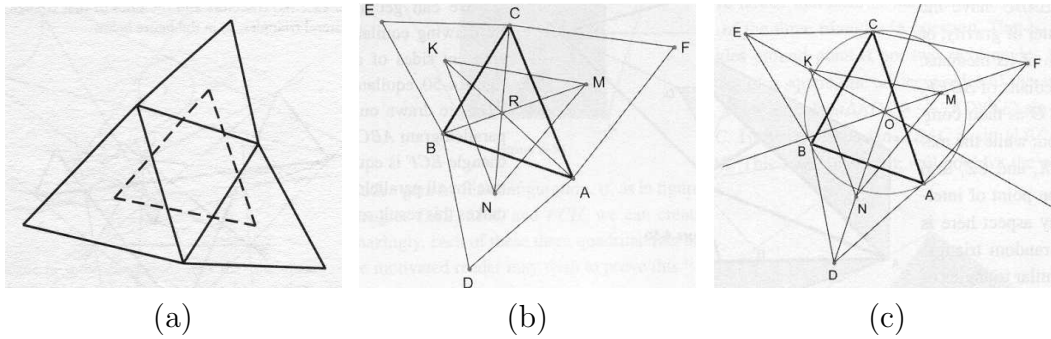

Figure 2.13: Napoleon's Theorem [322, 178, 245]

If, instead, the three equilateral triangles point inwards then another equilateral triangle is formed (the inner Napoleon triangle) and, moreover, the two Napoleon triangles share the same center with the original equilateral triangle and the difference in their areas is equal to the area of the original triangle [322]. (See [71] for a most interesting conjectured provenance for this theorem.) Also, the lines joining a vertex of either Napoleon triangle with the remote vertex of the original triangle are concurrent (Figure 2.13(b)) [245]. Finally, the lines joining each vertex of either Napoleon triangle to the new vertex of the corresponding equilateral triangle drawn on each side of the original equilateral triangle are concurrent and, moreover, the point of concurrency is the circumcenter of the original equilateral triangle (Figure 2.13(c)) [245].

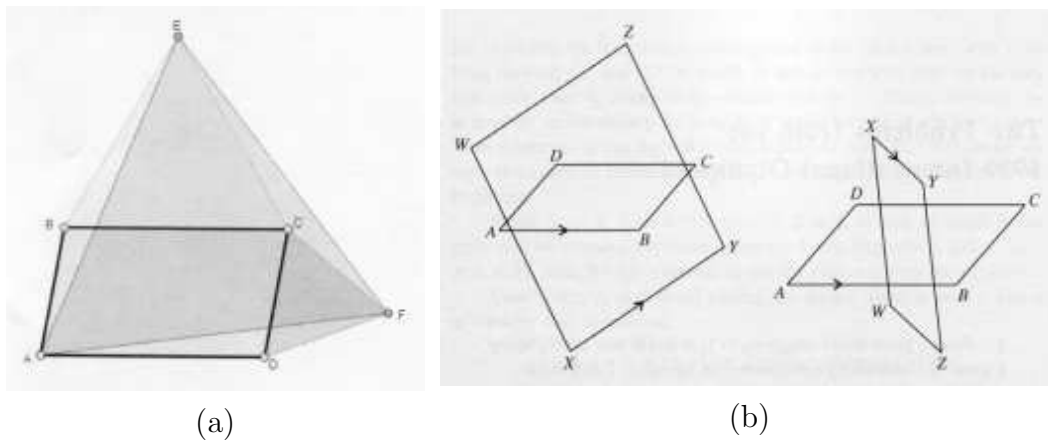

Figure 2.14: Parallelogram Properties [245].

Property 15 (Parallelogram Properties). *With reference to Figure 2.14(a), equilateral triangles BCE and CDF are constructed on sides BC and CD , respectively, of a parallelogram $ABCD$. Since triangles BEA , CEF and DAF are congruent, triangle AEF is equilateral [245]. With reference to Figure*

2.14(b) left/right, construct equilateral triangles pointing outwards/inwards on the sides of an oriented parallelogram $ABCD$ giving parallelogram $XYZW$. Then, if inward/outward pointing equilateral triangles are drawn on the sides of oriented parallelogram $XYZW$, the resulting parallelogram is just $ABCD$ again [182].

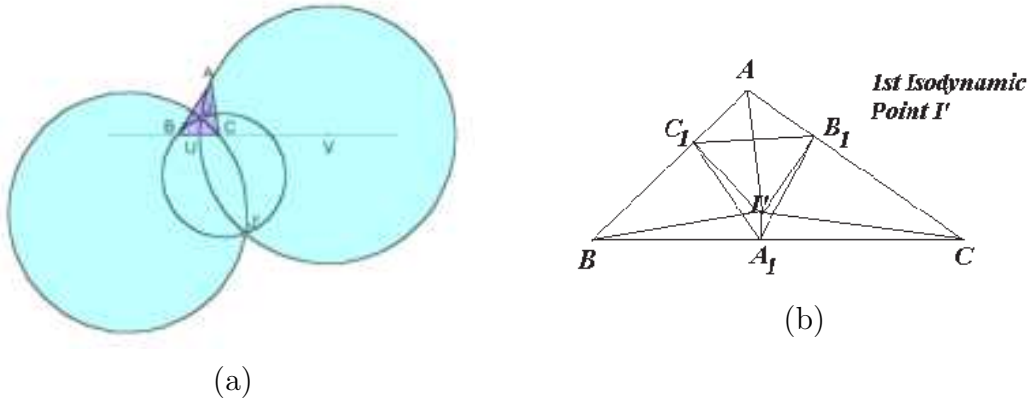

Figure 2.15: (a) Isodynamic (Apollonius) Points. (b) Pedal Triangle of First Isodynamic Point

Property 16 (Pedal Triangles of Isodynamic Points). *With reference to $\triangle ABC$ of Figure 2.15(a), let U and V be the points on \overline{BC} met by the interior and exterior bisectors of $\angle A$. The circle having diameter \overline{UV} is called the A -Apollonian circle [6]. The B - and C -Apollonian circles are likewise defined. These three Apollonian circles intersect at the first (J) and second (J') isodynamic (Apollonius) points [116]. With reference to Figure 2.15(b), connecting the feet of the perpendiculars from the first isodynamic point, I' , to the sides of $\triangle ABC$ produces its pedal triangle which is always equilateral [189]. The same is true for the pedal triangle of the second isodynamic point. This theorem generalizes as follows: The pedal triangle of any of the four points A, B, C, I' with respect to the triangle formed by the remaining points is equilateral [46, p. 303].*

Property 17 (The Machine for Questions and Answers). *In 2006, D. Dekov created a computer program, The Machine for Questions and Answers, and used it to produce The Computer-Generated Encyclopedia of Euclidean Geometry which contains the following results pertinent to equilateral triangles [73]. (Note: Connecting a point to the three vertices of a given triangle creates three new triangulation triangles associated with this point. Also, deleting the cevian triangle [6, p. 160] of a point with respect to a given triangle leaves three new corner triangles associated with this point.)*

- The pedal triangle of the first/second isodynamic point is equilateral.
- The antipedal triangle of the inner/outer Fermat point is equilateral.
- The circumcevian triangle of the first/second isodynamic point is equilateral.
- The inner/outer Napoleon triangle is equilateral.
- The triangle formed by the circumcenters of the triangulation triangles of the inner/outer Fermat point is equilateral.
- The triangle formed by the nine-point centers of the triangulation triangles of the inner/outer Fermat point is equilateral.
- The triangle formed by the first/second isodynamic points of the corner triangles of the orthocenter is equilateral.
- The triangle of the inner/outer Fermat points of the corner triangles of the Gergonne point is equilateral.
- The triangle formed by the first/second isodynamic points of the anticevian corner triangles of the incenter is equilateral.
- The triangle formed by the inner Fermat points of the anticevian corner triangles of the second isodynamic point is equilateral.
- The triangle formed by the reflections of the first isodynamic point in the sides of a given triangle is equilateral.

Property 18 (Musselman’s Theorem). *In May 1932, J. R. Musselman published a collection of results pertaining to the generation of equilateral triangles from equilateral triangles [223]. In the results to follow, a positively/negatively equilateral triangle $P_1P_2P_3$ is one whose vertices rotate into each other in a counterclockwise/clockwise direction, respectively.*

- Connected with two given positively equilateral triangles of any size or position, we can find three other equilateral triangles. Specifically, if $A_1A_2A_3$ and $B_1B_2B_3$ are the vertices of the two given triangles then the midpoints of $\{A_1B_1, A_2B_2, A_3B_3\}$ are the vertices of an equilateral triangle as are the midpoints of $\{A_1B_2, A_2B_3, A_3B_1\}$ and $\{A_1B_3, A_2B_1, A_3B_2\}$.
- Connected with three given positively equilateral triangles of any size or position with vertices $A_1A_2A_3$, $B_1B_2B_3$ and $C_1C_2C_3$, we can find 18 other equilateral triangles. This we do as follows.

- Combining by pairs in all possible, three, ways and connecting mid-points as above, we obtain 9 equilateral triangles.
- Also, the centroids of the three triangles $A_1B_1C_1$, $A_2B_2C_2$, $A_3B_3C_3$ themselves form an equilateral triangle. Moreover, the same is true if we fix the A_i and successively permute the B_i and C_i , for a total of 9 ways in which the A_i , B_i , C_i can be arranged so that the centroids of the three resulting triangles form an equilateral triangle. Incidentally, the centroid of each of the nine equilateral triangles thus formed is the same point!
- If the above three positively equilateral triangles be now so placed in the plane that $A_1B_1C_1$ forms a positively equilateral triangle, then there exist fifty-five equilateral triangles associated with this configuration! This we establish as follows.
 - First of all, the centroids of the three triangles $B_1C_1A_1$, $B_2C_2B_1$, $B_3C_3C_1$ form a positively equilateral triangle. To obtain the 9 equilateral triangles that can be thus formed, keep the last letters, A_1 , B_1 , C_1 , fixed and cyclically permute the remaining B_i and C_i . (E.g., the centroid of $B_1C_2B_1$ is the point on the segment B_1C_2 one third of the distance B_1C_2 from B_1 .)
 - Secondly, the midpoints of B_3C_2 , A_2C_3 , A_3B_2 form an additional equilateral triangle.
 - Finally, the existence of fifty-five equilateral triangles connected with the figure of three equilateral triangles, so placed in a plane that one vertex of each also forms an equilateral triangle, is now apparent. Taking the four given equilateral triangles in (six) pairs, each pair produces 3 additional equilateral triangles, or 18 in all. If we take the equilateral triangles in (four) triples, each triple yields 9 additional equilateral triangles, or 36 in all. Finally, there is the additional equilateral triangle just noted, thus making a total of 55 equilateral triangles which be easily constructed.
- Given two positively equilateral triangles, $A_1B_1C_1$ and $A_2B_2C_2$, of any size or position in the plane, if we construct the positively/negatively equilateral triangles $A_1A_2A_3$, $B_1B_2B_3$ and $C_1C_2C_3$ then $A_3B_3C_3$ is itself a positively equilateral triangle.

Property 19 (Distances from Vertices). *The symmetric equation*

$$3(a^4 + b^4 + c^4 + d^4) = (a^2 + b^2 + c^2 + d^2)^2$$

relates the side of an equilateral triangle to the distances of a point from its three corners [129, p. 65]. Any three variables can be taken for the three distances and solving for the fourth then gives the triangle's side.

The simplest solution in integers is 3, 5, 7, 8. One of a, b, c, d is divisible by 3, one by 5, one by 7 and one by 8 [159, p. 183], although they need not be distinct: (57,65,73,112) & (73,88,95,147).

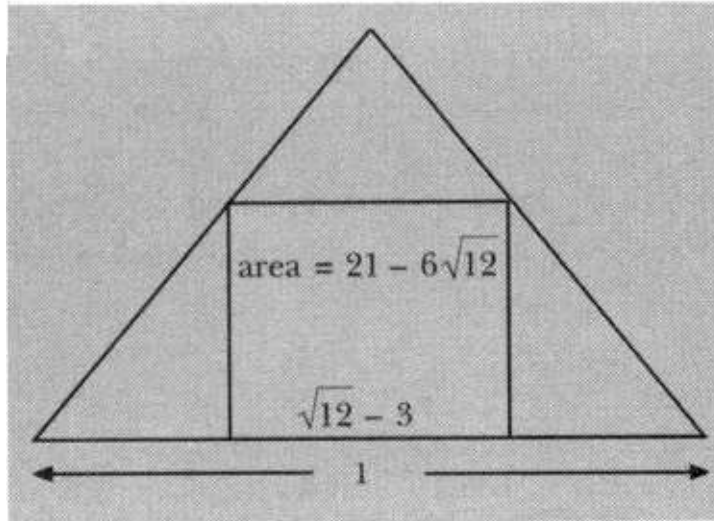

Figure 2.16: Largest Incribed Square [138]

Property 20 (Largest Incribed Square). *Figure 2.16 displays the largest square that can be inscribed in an equilateral triangle [138]. Its side is of length $2\sqrt{3} - 3 \approx 0.4641$ and its area is $21 - 12\sqrt{3} \approx 0.2154$.*

This is slightly smaller than the largest inscribed rectangle which can be constructed by dropping perpendiculars from the midpoints of any two sides to the third side. The feet of these perpendiculars together with the original two midpoints form the vertices of the largest inscribed rectangle whose base is half the triangle's base and whose area is half the triangle's area, $\frac{\sqrt{3}}{8} \approx 0.2165$. Moreover, this is the maximum area rectangle that fits inside the triangle regardless of whether or not it is inscribed.

Property 21 (Triangle in Square). *The smallest equilateral triangle inscribable in a unit square (Figure 2.17 left) has sides equal to unity and area equal to $\frac{\sqrt{3}}{4} \approx 0.4330$. The largest such equilateral triangle (Figure 2.17 right) has sides of length $\sqrt{6} - \sqrt{2} \approx 1.0353$ and area equal to $2\sqrt{3} - 3 \approx 0.4641$. [214]*

The more general problem of fitting the largest equilateral triangle into a given rectangle has been solved by Wetzel [326].

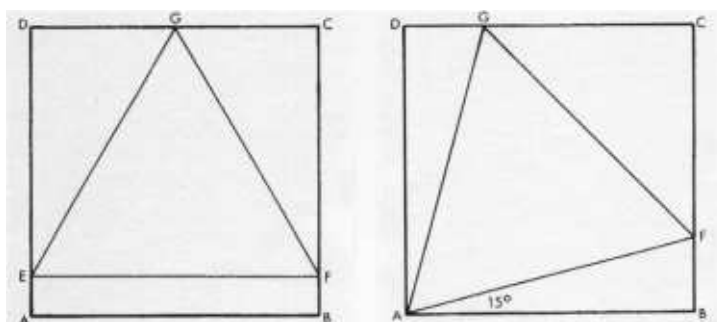

Figure 2.17: Inscribed Triangles: Smallest (Left) and Largest (Right) [214]

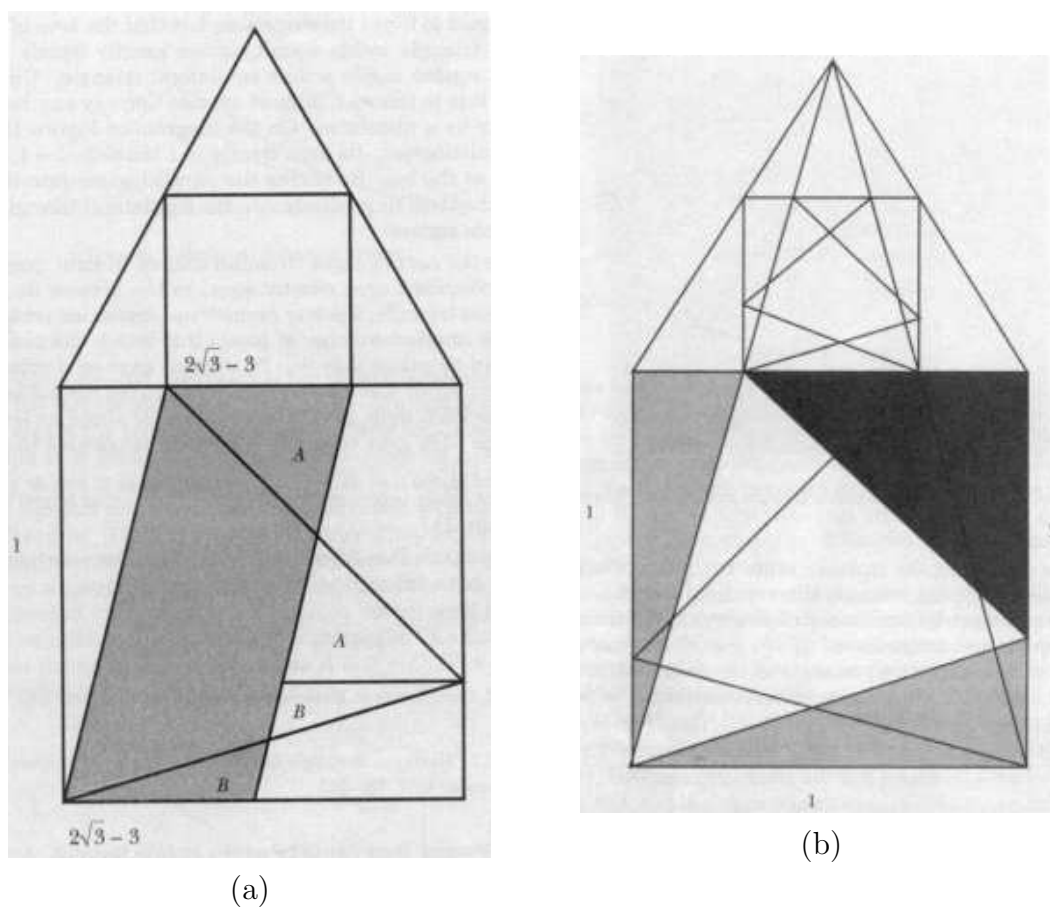

Figure 2.18: Syzygies: (a) Length Equals Area. (b) Related Constructions. [138]

Property 22 (Syzygies). (a) As can be concluded from the previous two Properties, M. Gardner has observed [138] that length of the side of the largest square that fits into an equilateral triangle of side 1 is the same as the area of the largest equilateral triangle that fits inside a unit square, in both cases $2\sqrt{3}-3$. Subsequently, J. Conway gave the dissection proof illustrated in Figure 2.18(a). The area of the shaded parallelogram is equal to $2\sqrt{3}-3$, the length of the side of the inscribed square, and may be dissected into three pieces as shown which fit precisely into the inscribed equilateral triangle. (b) B. Cipra discovered [138] that the endpoints of the baseline which constructs the largest square in the equilateral triangle also mark the points on the top of the larger square that are the top corners of the two maximum equilateral triangles that fit within the unit square (Figure 2.18(b)). Thus, juxtaposing these two diagrams produces a bilaterally symmetrical pattern illustrating the intimate connections between these two constructions.

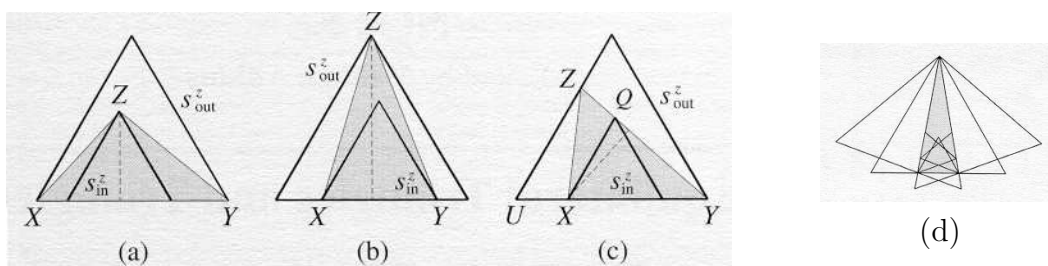

Figure 2.19: Equilateral Triangles and Triangles: (a)-(c) Three Possible Configurations. (d) Equal Equilateral Triangles. [188]

Property 23 (Equilateral Triangles and Triangles). In 1964, H. Steinhilber [292] posed the problem of finding a necessary and sufficient condition on the six sides a, b, c, a', b', c' for triangle T' with sides a', b', c' to fit in triangle T with sides a, b, c . In 1993, K. Post [247] succeeded by providing 18 inequalities whose disjunction is both necessary and sufficient. Post's proof hinges on the theorem that if one triangle fits within a second in any way whatsoever, then it also fits in such a way that one of its sides lies on a side of the containing triangle. Jerrard and Wetzel [188] have given geometric conditions for the more specialized problems of how large an equilateral triangle can fit into a given arbitrary triangle and how small an equilateral triangle can contain a given arbitrary triangle.

By Post's Theorem, the largest equilateral triangle Δ_{in} that fits in the given equilateral triangle $T = ABC$ does so with one side along a side of T , and T fits in the smallest equilateral triangle Δ_{out} that contains it with one of its sides along a side of Δ_{out} . Defining s_{in} to be the side of Δ_{in} and s_{out}^z to

be the side of the largest equilateral triangle Δ_{in}^z that fits in T with one side along side $z \in \{a, b, c\}$ of T , we have that $s_{in} = \max \{s_{in}^a, s_{in}^b, s_{in}^c\}$. Likewise, defining s_{out} to be the side of Δ_{out} and s_{out}^z to be the side of the smallest equilateral triangle Δ_{out}^z containing T with one side along side $z \in \{a, b, c\}$ of T , we have that $s_{out} = \min \{s_{out}^a, s_{out}^b, s_{out}^c\}$. They establish the surprising fact that Δ_{in} and Δ_{out} always rest on the same side of T . Curiously, the area of T is the geometric mean of the areas of Δ_{in}^z and Δ_{out}^z for each side z of T and thus of the areas of Δ_{in} and Δ_{out} . Figures 2.19(a-c) display the three possible configurations where z is the longest, shortest and median side of T , respectively.

They also show that Δ_{in} and Δ_{out} always lie on either the longest or the shortest side of T . If the median angle of T is at most 60° then they rest on the longest side. Otherwise, there is a complicated condition involving the median angle and its adjacent sides which determines whether they rest on the longest or the shortest side of T . Along the way, they work out the ordering relations among $s_{in}^a, s_{in}^b, s_{in}^c$ and $s_{out}^a, s_{out}^b, s_{out}^c$ which then permits the explicit calculation of s_{in} and s_{out} . It follows that if an equilateral triangle Δ of side s and a triangle T are given, then Δ fits within T precisely when $s \leq s_{in}$ and T fits within Δ precisely when $s \geq s_{out}$. Finally, they establish that the isosceles triangle with apex angle 20° is the unique nonequilateral triangle for which the three inner/outer maximal equilateral triangles are congruent (Figure 2.19(d)).

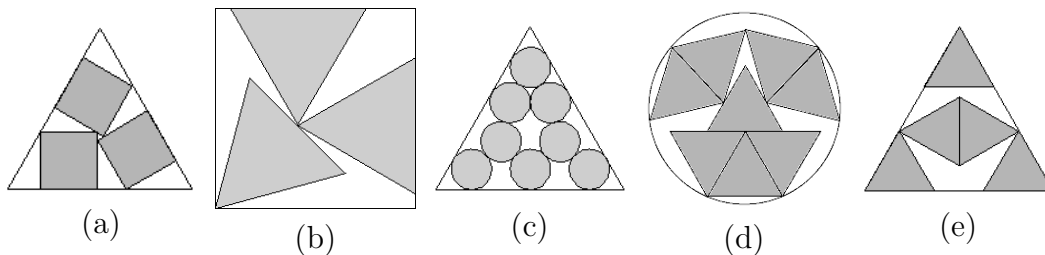

Figure 2.20: Packings: (a) Squares in Triangle. (b) Triangles in Square. (c) Circles in Triangle. (d) Triangles in Circle. (e) Triangles in Triangle. [110]

Property 24 (Packings). *The packing of congruent equilateral triangles, squares and circles into an equilateral triangle, a square or a circle has received considerable attention [110]. A sampling of some of the densest known packings is offered by Figure 2.20: (a) 3 squares in an equilateral triangle (Friedman 1997), (b) 3 equilateral triangles in a square (Friedman 1996), (c) 8 circles in an equilateral triangle (Melissen 1993), (d) 8 equilateral triangles in a circle (Morandi 2008), (e) 5 equilateral triangles in an equilateral triangle (Friedman 1997) [110]. The most exhaustively studied case is that of packing congruent circles into an equilateral triangle [220, 150].*

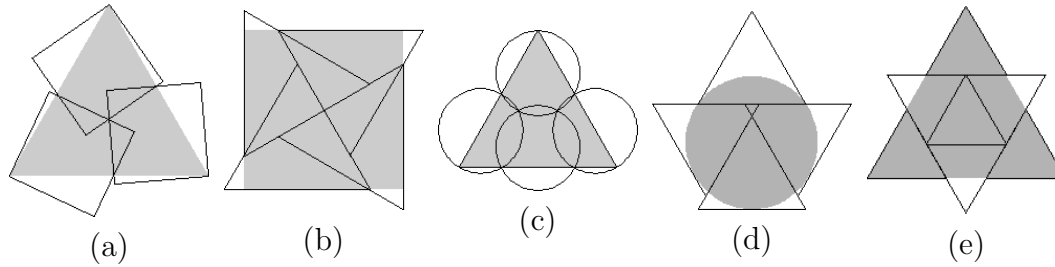

Figure 2.21: Coverings: (a) Squares on Triangle. (b) Triangles on Square. (c) Circles on Triangle. (d) Triangles on Circle. (e) Triangles on Triangle. [110]

Property 25 (Coverings). *The covering of an equilateral triangle, a square or a circle by congruent equilateral triangles, squares and circles has also received a fair amount of attention [110]. A sampling of some of the known optimal coverings is offered by Figure 2.21: (a) 3 squares on an equilateral triangle (Cantrell 2002), (b) 4 equilateral triangles on a square (Friedman 2002), (c) 4 circles on an equilateral triangle (Melissen 1997), (d) 4 equilateral triangles on a circle (Green 1999), (e) 7 equilateral triangles on an equilateral triangle (Friedman 1999) [110].*

Property 26 (Covering Properties). *A convex region that contains a congruent copy of each curve of a specified family is called a cover for the family. The following results concern equilateral triangular covers.*

- Every plane set of diameter one can be completely covered with an equilateral triangle of side $\sqrt{3} \approx 1.7321$ [178].
- The smallest equilateral triangle that can cover every triangle of diameter one has side $(2 \cos 10^\circ)/\sqrt{3} \approx 1.1372$ [325].
- The smallest triangular cover for the family of all closed curves of length two is the equilateral triangle of side $2\sqrt{3}/\pi \approx 1.1027$ [114], a result that follows from an inequality published in 1957 by Eggleston [94, p. 157].
- The smallest equilateral triangle that can cover every triangle of perimeter two has side $2/m_0 \approx 1.002851$, where m_0 is the global minimum of the the trigonometric function $\sqrt{3} \cdot (1 + \sin \frac{x}{2}) \cdot \sec(\frac{\pi}{6} - x)$ on the interval $[0, \pi/6]$ [325].

Property 27 (Blaschke's Theorem). *The width of a closed convex curve in a given direction is the distance between the two closest parallel lines, perpendicular to that direction, which enclose the curve. Blaschke proved that any closed convex curve whose minimum width is 1 unit or more contains a circle of diameter $2/3$ unit. An equilateral triangle contains just such a circle (its incircle), so the limit of $2/3$ is the best possible [322].*

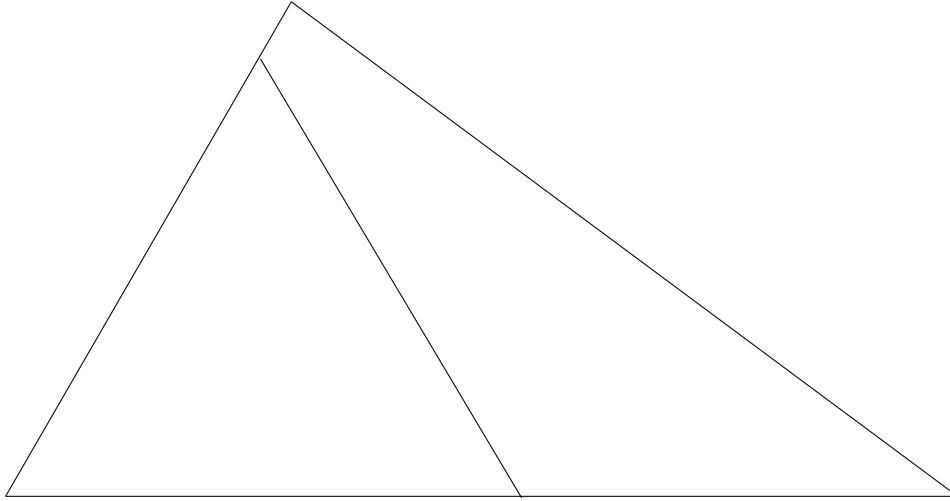

Figure 2.22: Euler Line Cuts Off Equilateral Triangle

Property 28 (Euler Line Cuts Off Equilateral Triangle). *If a triangle is not equilateral then the orthocenter (intersection of altitudes), the centroid (intersection of medians) and the circumcenter (intersection of perpendicular bisectors) are collinear [58]. (For an equilateral triangle, these three points coincide.) Many other important points associated with a triangle, such as the nine-point center, also lie on this so-called Euler line [6]. In a triangle with a 60° angle, the Euler line cuts off an equilateral triangle [28] (see Figure 2.22).*

Property 29 (Incircle-Triangle Iteration). *Let $\Delta A_0 B_0 C_0$ be arbitrary. Let the points of contact with its incircle be A_1, B_1, C_1 . Let the points of contact of $\Delta A_1 B_1 C_1$ with its incircle be A_2, B_2, C_2 , and so on. This sequence of triangles shrinks by a factor of $1/2$ at each iteration and approaches equiangularity in the limit [47].*

Property 30 (Excentral Triangle Iteration). *The bisector of any interior angle of a triangle and those of the exterior angles at the other two vertices are concurrent at a point outside the triangle. These three points are called excenters and they are the vertices of the excentral triangle. Commencing with an arbitrary triangle, construct its excentral triangle, then construct the excentral triangle of this excentral triangle, and so on. These excentral triangles approach an equilateral triangle [189].*

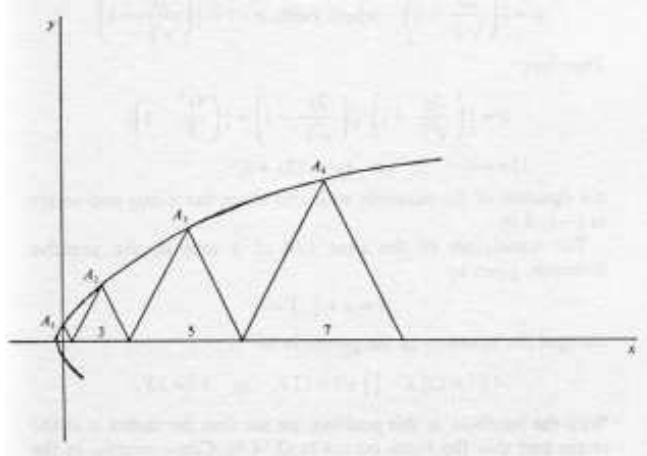

Figure 2.23: Abutting Equilateral Triangles [179]

Property 31 (Abutting Equilateral Triangles). *Equilateral triangles of sides $1, 3, 5, \dots, 2n - 1, \dots$ are placed end-to-end along a straight line (Figure 2.23). The vertices which do not lie on the line all lie on a parabola and their focal radii are all integers [179].*

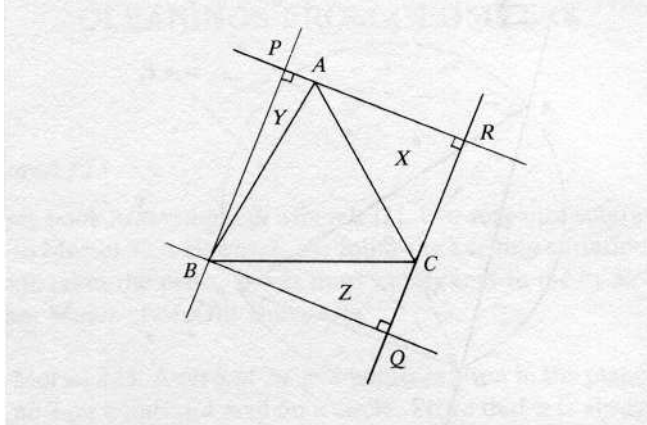

Figure 2.24: Circumscribing Rectangle [181]

Property 32 (Circumscribing Rectangle). *Around any equilateral triangle ABC , circumscribe a rectangle $PBQR$ (Figure 2.24). In general, each side of ABC cuts off a right triangle from the rectangle. The areas of the two smaller right triangles always add up to the area of the largest one ($X = Y + Z$) [181].*

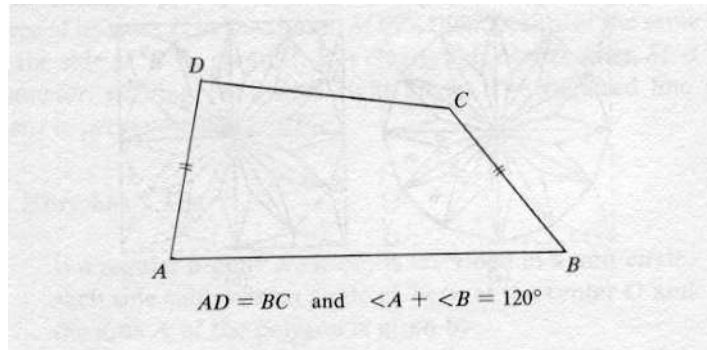
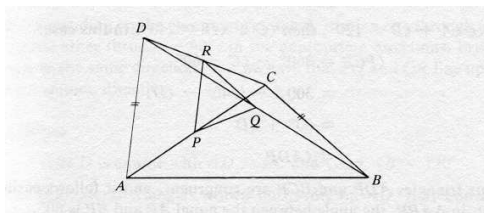
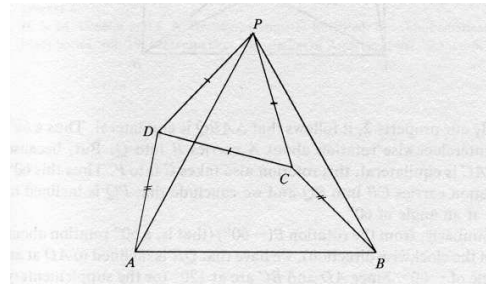

Figure 2.25: Equilic Quadrilateral [181]

Property 33 (Equilic Quadrilaterals). *With reference to Figure 2.25, a quadrilateral $ABCD$ is equilic if $AD = BC$ and $\angle A + \angle B = 120^\circ$. Figure 2.26(a): The midpoints P , Q and R of the diagonals and the side CD always determine an equilateral triangle. Figure 2.26(b): If an equilateral triangle PCD is drawn outwardly on CD then $\triangle PAB$ is also equilateral [181].*



(a)



(b)

Figure 2.26: (a) Equilic Midpoints. (b) Equilic Triangles. [181]

Property 34 (The Only Rational Triangle). *If a triangle has side lengths which are all rational numbers and angles which are all a rational number of degrees then the triangle must be equilateral [55]!*

Property 35 (Six Triangles). *From an arbitrary point in an equilateral triangle, segments to the vertices and perpendiculars to the sides partition the triangle into six smaller triangles A , B , C , D , E , F (see Figure 2.27 left). Claim [183]:*

$$A + C + E = B + D + F.$$

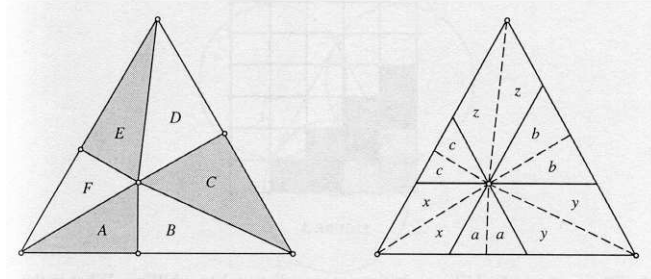

Figure 2.27: Six Triangles [183]

Drawing three additional lines through the selected point which are parallel to the sides of the original triangle partitions it into three parallelograms and three small equilateral triangles (Figure 2.27 right). Since the areas of the parallelograms are bisected by their diagonals and the equilateral triangles by their altitudes,

$$A + C + E = x + a + y + b + z + c = B + D + F.$$

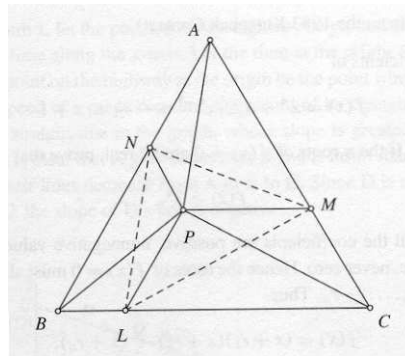

Figure 2.28: Pompeiu's Theorem [184]

Property 36 (Pompeiu's Theorem). *If P is an arbitrary point in an equilateral triangle ABC then there exists a triangle with sides of length PA , PB , PC [184].*

Draw segments PL , PM , PN parallel to the sides of the triangle (Figure 2.28). Then, the trapezoids $PMAN$, $PNBL$, $PLCM$ are isosceles and thus have equal diagonals. Hence, $PA = MN$, $PB = LN$, $PC = LM$ and $\triangle LMN$ is the required triangle. Note that the theorem remains valid for any point P in the plane of $\triangle ABC$ [184] and that the triangle is degenerate if and only if P lies on the circumcircle of $\triangle ABC$ [267].

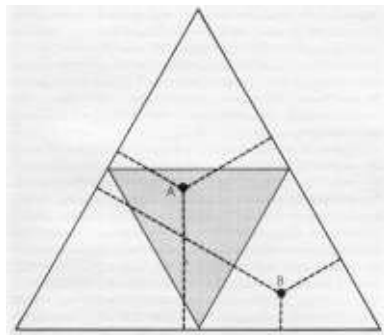

Figure 2.29: Random Point [177]

Property 37 (Random Point). *A point P is chosen at random inside an equilateral triangle. Perpendiculars from P to the sides of the triangle meet these sides at points X, Y, Z . The probability that a triangle with sides PX, PY, PZ exists is equal to $\frac{1}{4}$ [177].*

As shown in Figure 2.29, the segments satisfy the triangle inequality if and only if the point lies in the shaded region whose area is one fourth that of the original triangle [122]. Compare this result to Pompeiu's Theorem!

Property 38 (Gauss Plane). *In the Gauss (complex) plane [81], ΔABC is equilateral if and only if*

$$(b - a)\lambda_{\pm}^2 = (c - b)\lambda_{\pm} = a - c; \quad \lambda_{\pm} := (-1 \pm i\sqrt{3})/2.$$

For λ_{\pm} , ΔABC is described counterclockwise/clockwise, respectively.

Property 39 (Gauss' Theorem on Triangular Numbers). *In his diary of July 10, 1796, Gauss wrote [290]:*

$$\text{“EΥPHKA! num} = \Delta + \Delta + \Delta\text{.”}$$

I.e., “Eureka! Every positive integer is the sum of at most three triangular numbers.”

As early as 1638, Fermat conjectured much more in his polygonal number theorem [319]: “Every positive integer is a sum of at most three triangular numbers, four square numbers, five pentagonal numbers, and n n -polygonal numbers.” (Alas, his margin was once again too narrow to hold his proof!) Jacobi and Lagrange proved the square case in 1772, Gauss the triangular case in 1796, and Cauchy the general case in 1813 [320].

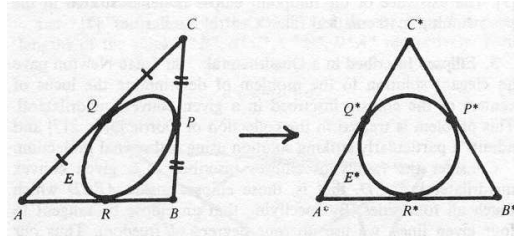

Figure 2.30: Equilateral Shadows [180]

Property 40 (Equilateral Shadows). *Any triangle can be orthogonally projected onto an equilateral triangle [180]. Moreover, under the inverse of this transformation, the incircle of the equilateral triangle is mapped to the “mid-point ellipse” of the original triangle with center at the triangle centroid and tangent to the triangle sides at their midpoints (Figure 2.30).*

Note that this demonstrates that if we cut a triangle from a piece of paper and hold it under the noonday sun then we can always position the triangle so that its shadow is an equilateral triangle.

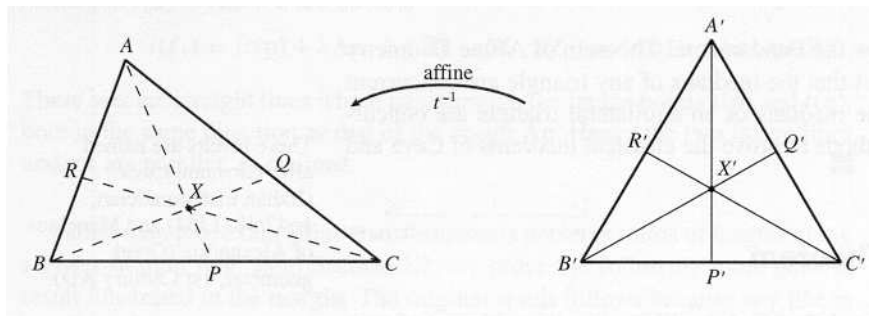

Figure 2.31: Fundamental Theorem of Affine Geometry [33]

Property 41 (Affine Geometry). *All triangles are affine-congruent [33]. In particular, any triangle may be affinely mapped onto any equilateral triangle (Figure 2.31).*

This theorem is of fundamental importance in the theory of Riemann surfaces. E.g. [288, p. 113]:

Theorem 2.1 (Riemann Surfaces). *If an arbitrary manifold \mathcal{M} is given which is both triangulable and orientable then it is possible to define an analytic structure on \mathcal{M} which makes it into a Riemann surface.*

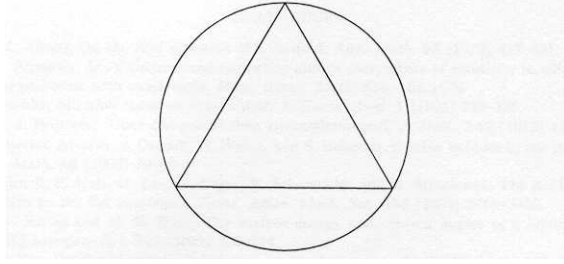

Figure 2.32: Largest Inscribed Triangle and Least-Diameter Decomposition of the Open Disk [4]

Property 42 (Largest Inscribed Triangle). *The triangle of largest area that is inscribed in a given circle is the equilateral triangle (Figure 2.32) [249].*

Property 43 (Planar Soap Bubble Clusters). *An inscribed equilateral triangle (Figure 2.32) provides a least-diameter smooth decomposition of the open unit disk into relatively closed sets that meet at most two at a point [4].*

Property 44 (Jung's Theorem). *Let d be the (finite) diameter of a planar set and let r be the radius of its smallest enclosing circle. Then, [249]*

$$r \leq \frac{d}{\sqrt{3}}.$$

Since the circumcircle is the smallest enclosing circle for an equilateral triangle (Figure 2.32), this bound cannot be diminished.

Property 45 (Isoperimetric Theorem for Triangles). *Among triangles of a given perimeter, the equilateral triangle has the largest area [191]. Equivalently, among all triangles of a given area, the equilateral triangle has the shortest perimeter [228].*

Property 46 (A Triangle Inequality). *If A is the area and L the perimeter of a triangle then*

$$A \leq \sqrt{3}L^2/36,$$

with equality if and only if the triangle is equilateral [228].

Property 47 (Euler's Inequality). *If r and R are the radii of the inscribed and circumscribed circles of a triangle then*

$$R \geq 2r,$$

with equality if and only if the triangle is equilateral [191, 228].

Property 48 (Erdős-Mordell Inequality). *Let R_1, R_2, R_3 be the distances to the three vertices of a triangle from any interior point P . Let r_1, r_2, r_3 be the distances from P to the three sides. Then*

$$R_1 + R_2 + R_3 \geq 2(r_1 + r_2 + r_3),$$

with equality if and only if the triangle is equilateral and P is its centroid [191, 228].

Property 49 (Blundon's Inequality). *In any triangle ABC with circumradius R , inradius r and semi-perimeter σ , we have that*

$$\sigma \leq 2R + (3\sqrt{3} - 4)r,$$

with equality if and only if ABC is equilateral [26].

Property 50 (Garfunkel-Bankoff Inequality). *If A_i ($i = 1, 2, 3$) are the angles of an arbitrary triangle, then we have*

$$\sum_{i=1}^3 \tan^2 \frac{A_i}{2} \geq 2 - 8 \prod_{i=1}^3 \sin \frac{A_i}{2},$$

with equality if and only if ABC is equilateral [331].

Property 51 (Improved Leunberger Inequality). *If s_i ($i = 1, 2, 3$) are the sides of an arbitrary triangle with circumradius R and inradius r , then we have*

$$\sum_{i=1}^3 \frac{1}{s_i} \geq \frac{\sqrt{25Rr - 2r^2}}{4Rr},$$

with equality if and only if ABC is equilateral [331].

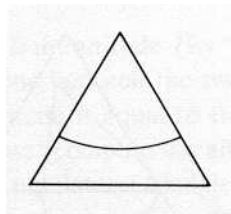

Figure 2.33: Shortest Bisecting Path [161]

Property 52 (Shortest Bisecting Path). *The shortest path across an equilateral triangle of side s which bisects its area is given by a circular arc with center at a vertex and with radius chosen to bisect the area (Figure 2.33) [228].*

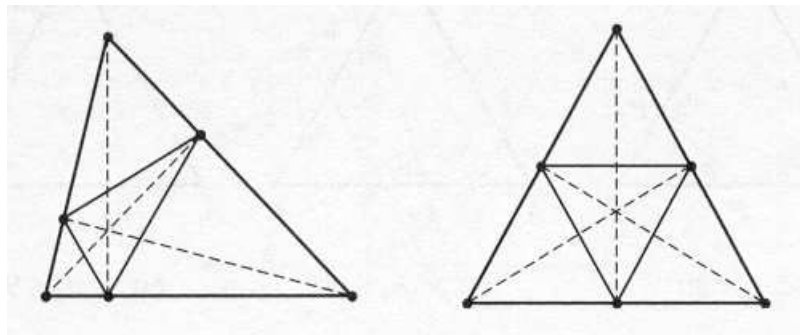

Figure 2.34: Smallest Incribed Triangle [57, 62]

This radius is equal to $s \cdot \sqrt{\frac{3\sqrt{3}}{4\pi}}$ [161] so that the circular arc has length $.673\dots s$ which is much shorter than either the $.707\dots s$ length of the parallel bisector or the $.866\dots s$ length of the altitude.

Property 53 (Smallest Incribed Triangle). *The problem of finding the triangle of minimum perimeter inscribed in a given acute triangle [62] was posed by Giulio Fagnano and solved using calculus by his son Giovanni Fagnano in 1775 [224]. (An inscribed triangle being one with a vertex on each side of the given triangle.) The solution is given by the orthic/pedal triangle of the given acute triangle (Figure 2.34 left).*

Later, H. A. Schwarz provided a geometric proof using mirror reflections [57]. Call the process illustrated on the left of Figure 2.34 the pedal mapping. Then, the unique fixed point of the pedal mapping is the equilateral triangle [194]. That is, the equilateral triangle is the only triangle that maintains its form under the pedal mapping. Also, the equilateral triangle is the only triangle for which successive pedal iterates are all acute [205]. Finally, the maximal ratio of the perimeter of the pedal triangle to the perimeter of the given acute triangle is $1/2$ and the unique maximizer is given by the equilateral triangle [158]. For a given equilateral triangle, the orthic/pedal triangle coincides with the medial triangle which is itself equilateral (Figure 2.34 right).

Property 54 (Closed Light Paths [57]). *The walls of an equilateral triangular room are mirrored. If a light beam emanates from the midpoint of a wall at an angle of 60° , it is reflected twice and returns to its point of origin by following a path along the pedal triangle (see Figure 2.34 right) of the room. If it originates from any other point along the boundary (exclusive of corners) at an angle of 60° , it is reflected five times and returns to its point of origin by following a path everywhere parallel to a wall (Figure 2.35) [57].*

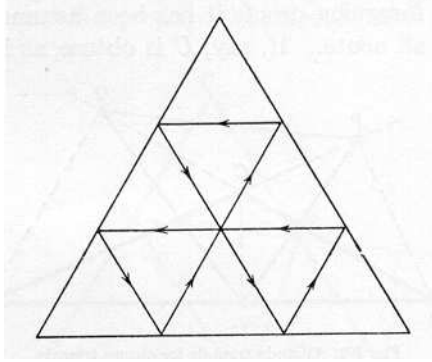

Figure 2.35: Closed Light Paths [57]

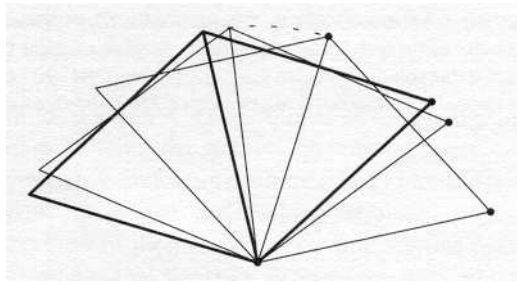

Figure 2.36: Erdős-Moser Configuration [235]

Property 55 (Erdős-Moser Configuration). *An equilateral triangle of side-length one is called a unit triangle. A set of points S is said to span a unit triangle T if the vertices of T belong to S . n points in the plane are said to be in strictly convex position if they form the vertex set of a convex polygon for which each of the points is a corner. Pach and Pinchasi [235] have proved that any set of n points in strictly convex position in the plane has at most $\lfloor 2(n-1)/3 \rfloor$ triples that span unit triangles. Moreover, this bound is sharp for each $n > 0$.*

This maximum is attained by the Erdős-Moser configuration of Figure 2.36. This configuration contains $\lfloor (n-1)/3 \rfloor$ congruent copies of a rhombus with side-length one and obtuse angle $2\pi/3$, rotated by small angles around one of its vertices belonging to such an angle [235].

Property 56 (Reuleaux Triangle). *With reference to Figure 2.37(a), the Reuleaux triangle is obtained by replacing each side of an equilateral triangle by a circular arc with center at the opposite vertex and radius equal to the length of the side [125].*

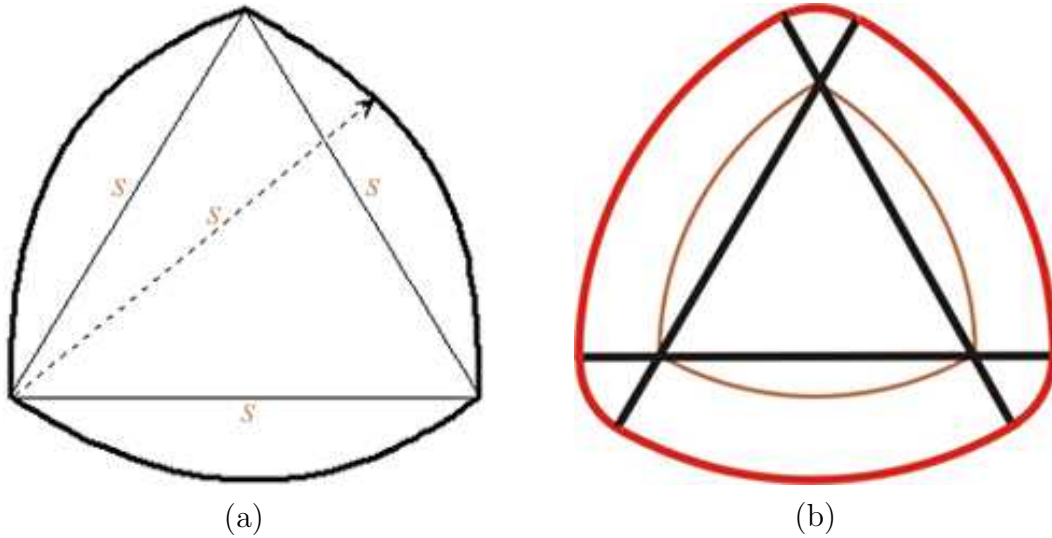

Figure 2.37: Curves of Constant Width: (a) Sharp Reuleaux Triangle. (b) Rounded Reuleaux Triangle.

Like the circle, it is a curve of constant breadth, the breadth (width) being equal to the length of the triangle side [291]. Whereas the circle encloses the largest area amongst constant-width curves with a fixed width, w , the Reuleaux triangle encloses the smallest area amongst such curves (Blaschke-Lebesgue Theorem) [39]. (The enclosed area is equal to $(\pi - \sqrt{3})w^2/2$ [125]; by Barbier's theorem [39], the perimeter equals πw) Moreover, a constant-width curve cannot be more pointed than 120° , with the Reuleaux triangle being the only one with a corner of 120° [249]. Like all curves of constant-width, the Reuleaux triangle is a rotor for a square, i.e. it can be rotated so as to maintain contact with the sides of the square, but the center of rotation is not fixed [241]. In the case of the Reuleaux triangle, the square with rounded corners that is out swept out has area that is approximately equal to .9877 times the area of the square. (See Application 25.) The corners of the Reuleaux triangle can be smoothed by extending each side of the equilateral triangle a fixed distance at each end and then constructing six circular arcs centered at the vertices as shown in Figure 2.37(b). The constant-width of the resulting smoothed Reuleaux triangle is equal to the sum of the two radii so employed [125].

Property 57 (Least-Area Rotor). *The least-area rotor for an equilateral triangle is formed from two 60° circular arcs with radius equal to the altitude of the triangle [291] (which coincides with the length of the rotor [322]) (Figure 2.38). (The incircle is the greatest-area rotor [39].)*

As it rotates, its corners trace the entire boundary of the triangle without rounding of corners [125], although it must slip as it rolls [291].

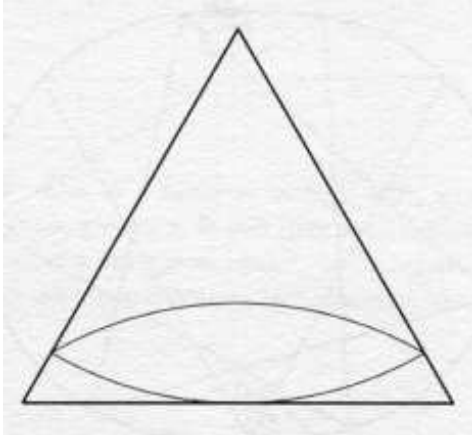

Figure 2.38: Least-Area Rotor

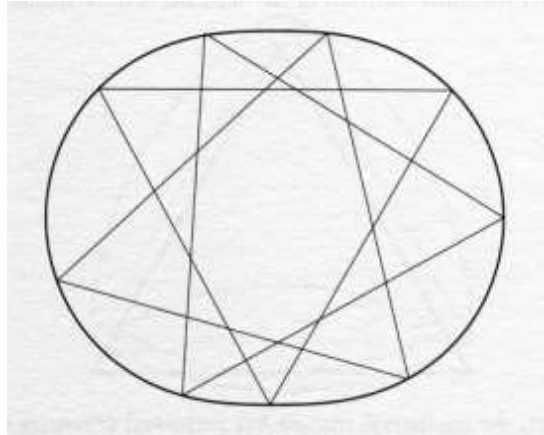

Figure 2.39: Triangular Rotor

Property 58 (Equilateral Triangular Rotor). *Obviously, the equilateral triangle is a rotor for a circle. Yet, it can also be a rotor for a noncircular cylinder.*

Figure 2.39 shows the curve given parametrically as

$$x(t) = \cos t + .1 \cos 3t; \quad y(t) = \sin t + .1 \sin 3t,$$

within which rotates an equilateral triangular piston [291]. (See Application 26.)

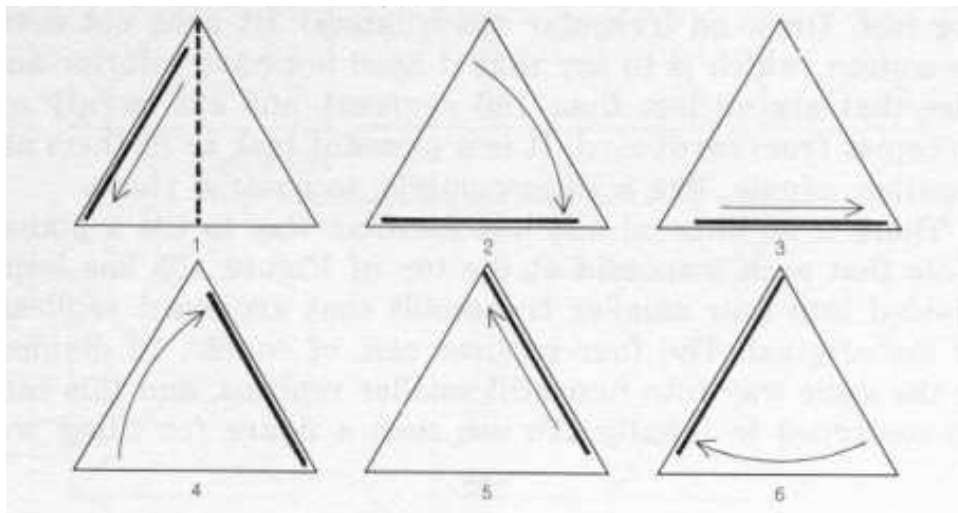

Figure 2.40: Kakeya Needle Problem [125]

Property 59 (Kakeya Needle Problem). *The convex plane figure of least area in which a line segment of length 1 can be rotated through 180° , returning to its original position with reversed orientation, is an equilateral triangle with altitude 1 (area $1/\sqrt{3}$) [125].*

The required rotation is illustrated in Figure 2.40. If the constraint of convexity is removed then there is no such plane figure of smallest area [14, pp. 99-101]!

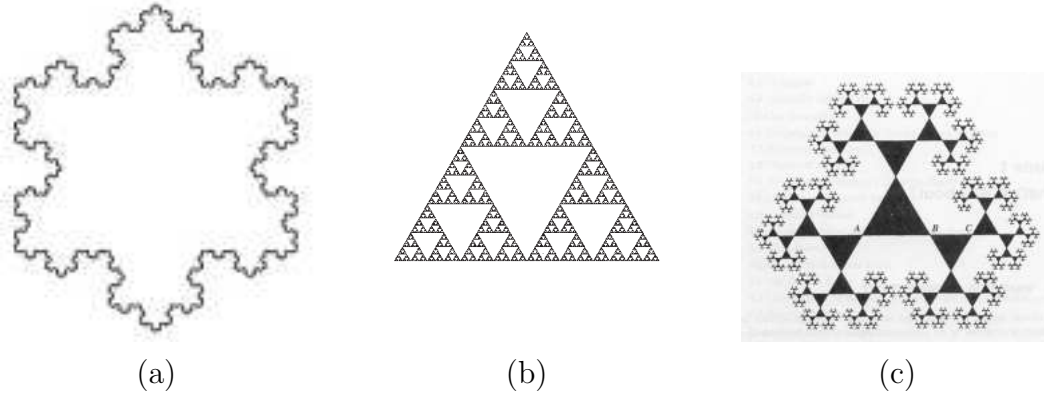

Figure 2.41: Equilateral Triangular Fractals: (a) Koch Snowflake [133]. (b) Sierpinski Gasket [314]. (c) Golden Triangle Fractal [314].

Property 60 (Equilateral Triangular Fractals). *The equilateral triangle is eminently suited for the construction of fractals.*

In Figure 2.41(a), the Koch Snowflake is constructed by successively replacing the middle third of each edge by the other two sides of an equilateral triangle [100]. Although the perimeter is infinite, the area bounded by the curve is exactly $\frac{8}{5}$ that of the initial triangle [133] and its fractal dimension is $\log 4 / \log 3 \approx 1.2619$ [322]. (The “anti-snowflake” curve is obtained if the appended equilateral triangles are turned inwards instead of outwards, with area $\frac{2}{5}$ of the original triangle [66].) In Figure 2.41(b), the Sierpinski Gasket is obtained by repeatedly removing (inverted) equilateral triangles from an initial equilateral triangle [100]. Its fractal dimension is equal to $\log 3 / \log 2 \approx 1.5850$. In Figure 2.41(c), the Golden Triangle Fractal is generated from an initial equilateral triangle by successively adding to any free corner at each stage an equilateral triangle scaled in size by $\frac{1}{\phi}$ where $\phi = \frac{1+\sqrt{5}}{2}$ is the golden section [314]. Its fractal dimension is equal to $\log 2 / \log \phi \approx 1.4404$.

Property 61 (Pascal’s Triangle). *In 1654, Pascal published *Traité du triangle arithmétique* wherein he intensively studied the *Arithmetical Triangle (PAT)* shown in Figure 2.42(a), where each entry is the sum of its northwestern and northeastern neighbors [93].*

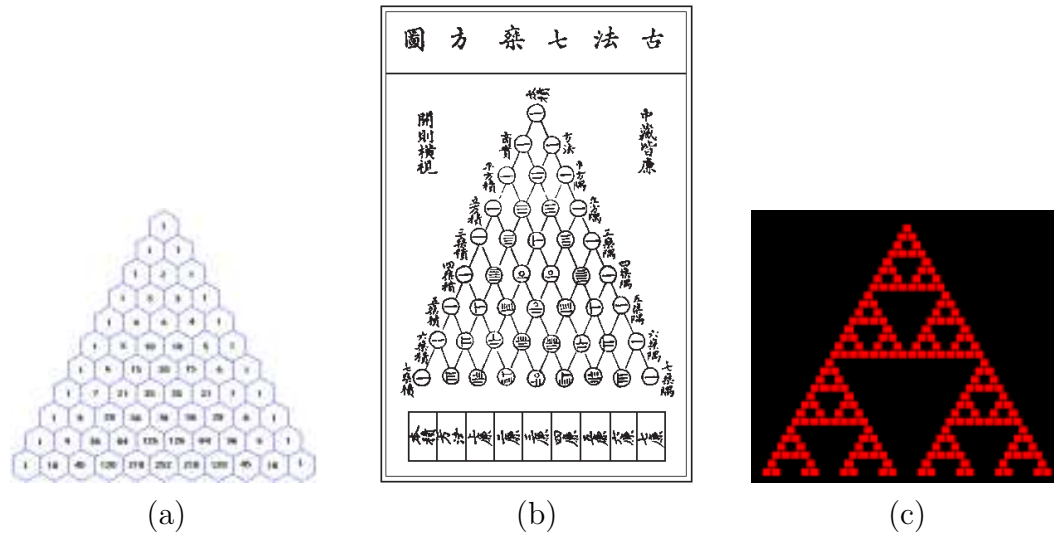

Figure 2.42: Pascal’s Triangle (PT): (a) Arithmetical PT (1654). (b) Chinese PT (1303) . (c) Fractal PT (1965).

It is in fact much older, appearing in the works of Mathematicians throughout Persia, India and China. One such instance is shown in Figure 2.42(b), which is taken from Chu shih-chieh’s *Precious Mirror of the Four Elements* of 1303. Can you find the mistake which is buried therein? (Hint: Look in Row 7, where rows are numbered beginning at 0.)

The mathematical treasures hidden within PAT are truly staggering, e.g. the binomial coefficients and the triangular numbers, but we will focus our attention on the following gem. Consider what happens when odd numbers in PAT are darkened and even numbers are left blank. Extending PAT to infinitely many rows and reducing the scale by one-half each time the number of rows is doubled produces the previously encountered fractal, Sierpinski’s Gasket (Figure 2.42(c)) [127]!

Property 62 (The Chaos Game). *Equilateral triangular patterns can emerge from chaotic processes.*

Choose any point lying within an equilateral triangle, the vertices of which are labeled 1 thru 3, and mark it with a small dot. Roll a cubic die to produce a number n and set $i = (n \bmod 3) + 1$. Generate a new point located at the midpoint of the segment connecting the previous dot with vertex i and mark it with a small dot. Iterate this process k times always connecting the most recent dot with the latest randomly generated vertex. The results for (a) $k = 100$, (b) $k = 500$, (c) $k = 1,000$ and (d) $k = 10,000$ are plotted in Figure 2.43. Voila, Sierpinski’s Gasket emerges from this chaotic process [239, Chapter 6]!

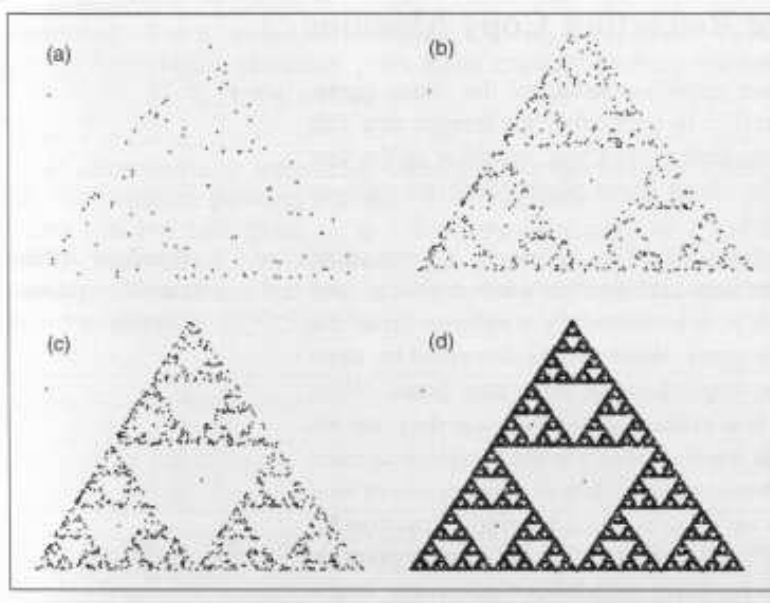

Figure 2.43: Chaos Game [239]

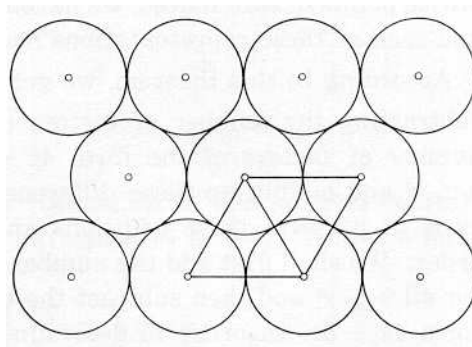

Figure 2.44: Equilateral Lattice [172]

Property 63 (Equilateral Lattice). *Let c denote the minimum distance between two points in a unit lattice, i.e. one constructed from an arbitrary parallelogram of unit area [172]. Then, $c \leq \sqrt{\frac{2}{\sqrt{3}}}$, and this upper bound is achieved by the lattice generated by a parallelogram that is composed of two equilateral triangles (i.e. by a “regular rhombus”).*

Moreover, for a given value of c , this lattice has the smallest possible generating parallelogram. Asymptotically, of all lattices with a given c , the lattice composed of equilateral triangles has the greatest number of points in a given large region. Finally, the lattice of equilateral triangles gives rise to the densest packing of circles of radius $\frac{c}{2}$ (Figure 2.44) with density $D = \frac{\pi}{2\sqrt{3}} \approx .907$.

Property 64 (No Equilateral Triangles on a Chess Board). *There is no equilateral triangle whose vertices are plane lattice points [96].*

This was one of 24 theorems proposed in a survey on The Most Beautiful Theorems in Mathematics [321]. It came in at Number 19. In general, a triangle is embeddable in \mathbf{Z}^2 if and only if all of its angles have rational tangents [17]. Of course, the equilateral triangle is embeddable in \mathbf{Z}^n ($n \geq 3$): $\{(1, 0, 0, \dots), (0, 1, 0, \dots), (0, 0, 1, \dots)\}$. M. J. Beeson has provided a complete characterization of the triangles embeddable in \mathbf{Z}^n for each n [17].

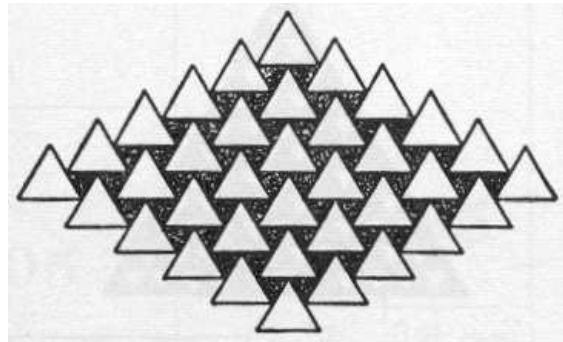

Figure 2.45: Equilateral Triangular Mosaic [199]

Property 65 (Regular Tessellations of the Plane). *The only regular tessellations of the plane by polygons of the same kind meeting only at a vertex are provided by equilateral triangles, squares and regular hexagons. If a vertex of one polygon is allowed to lie on the side of another then the only such tessellations are afforded by equilateral triangles (Figure 2.45) and squares [199, pp. 199-202].*

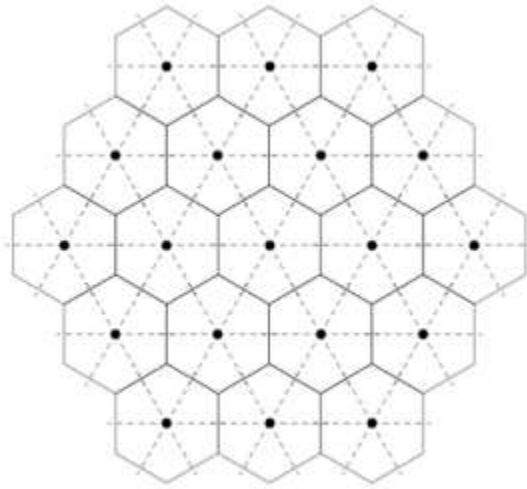

Figure 2.46: Dirichlet Duality [232]

Property 66 (Triangular and Hexagonal Lattice Duality). *The Dirichlet (Voronoi) region associated with a lattice point is the set of all points closer to it than to any other lattice point [232]. The regular hexagonal and equilateral triangular lattices are dual to one another in the sense that they are each other's Dirichlet tessellation (Voronoi diagram) (Figure 2.46) [209].*

Property 67 (From Tessellations to Fractals). *An infinite sequence of tessellating shapes based upon the equilateral triangle may give rise to a limiting fractal pattern [234].*

Begin by dissecting an equilateral triangle, the Level 0 tile, into sixteen smaller copies, three of which are shown in Figure 2.47(a), by subdividing each edge into fourths. Then, hinging these three as shown in Figure 2.47(b) and rotating them counterclockwise as in Figure 2.47(c) produces the Level 1 tile of Figure 2.47(d). The same tripartite process of dissect, hinge and rotate may be applied to this Level 1 tile to produce the Level 2 tile of Figure 2.48. The dissection process is illustrated in Figure 2.49 and the net result of hinging and rotating is on display in Figure 2.50. This process of dissection into 16 congruent pieces followed by hinge-rotation followed by a size reduction of one-fourth (in length) leads to an infinite cascade of shapes (Level 3 is shown in Figure 2.51) which lead, in the limit, to a self-similar fractal shape. Other Level 0 shapes based upon the equilateral triangle and square may be investigated [234].

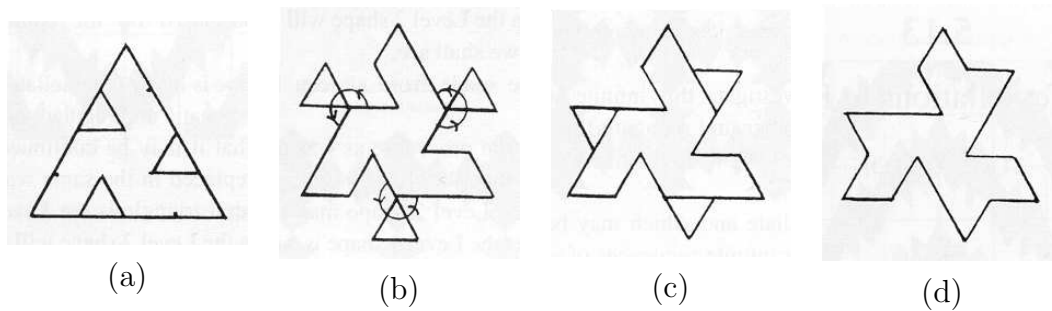

Figure 2.47: Level 1: (a) Dissect. (b) Hinge. (c) Rotate. (d) Tile. [234]

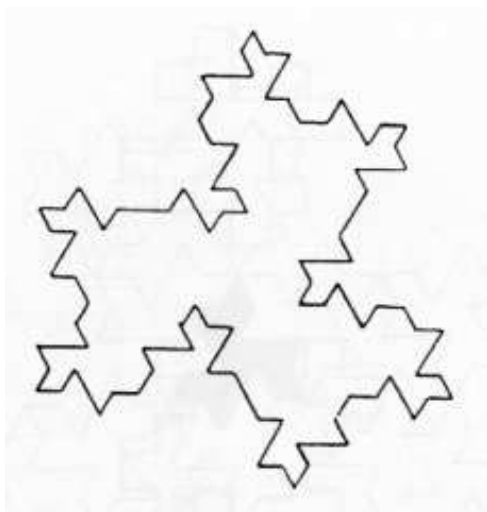

Figure 2.48: Level 2

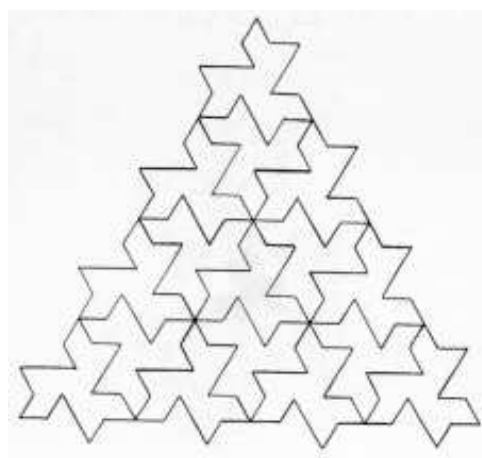

Figure 2.49: Level 1 Tessellation

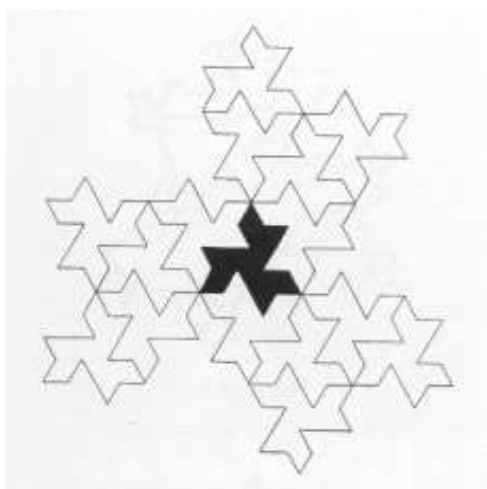

Figure 2.50: Level 2 Reprise

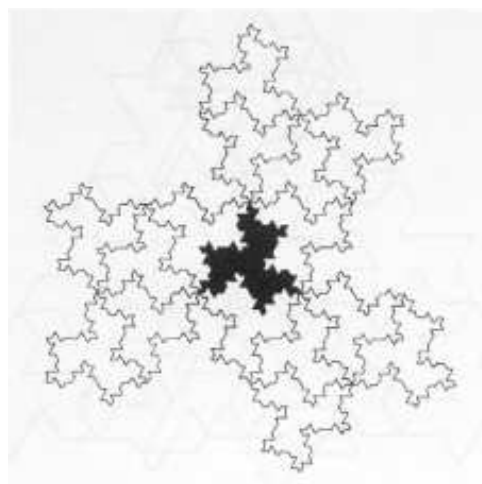

Figure 2.51: Level 3

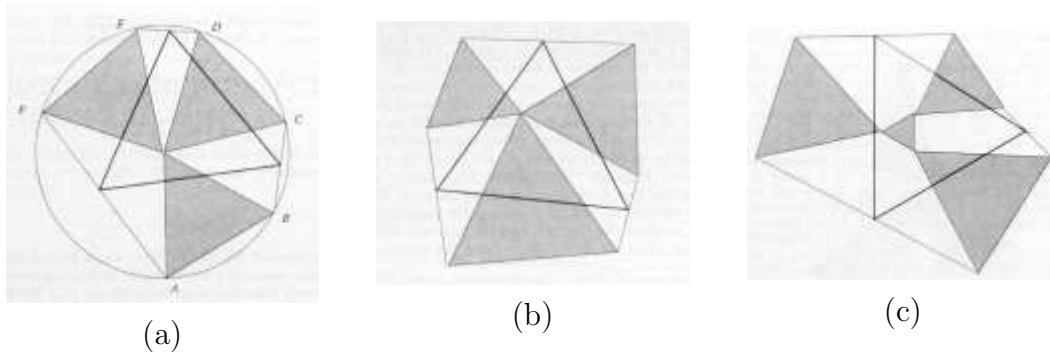

Figure 2.52: Propeller Theorem: (a) Symmetric Propellers. (b) Asymmetric Propellers. (c) Triangular Hub. [138]

Property 68 (The Propeller Theorem). *The Propeller Theorem states that the midpoints of the three chords connecting three congruent equilateral triangles which are joined at a vertex lie at the vertices of an equilateral triangle (Figure 2.52(a)) [138].*

In fact, the triangular propellers may even touch along an edge or overlap. The Asymmetric Propeller Theorem states that the three equilateral triangles need not be congruent (Figure 2.52(b)). The Generalized Asymmetric Propeller Theorem states the propellers need not meet at a point but may meet at the vertices of an equilateral triangle (Figure 2.52(c)). Finally, the General Generalized Asymmetric Propeller Theorem states the the propellers need not even be equilateral, as long as they are all similar triangles! If they do not meet at a point then they must meet at the vertices of a fourth similar triangle and the vertices of the triangular hub must meet the propellers at their corresponding corners [138].

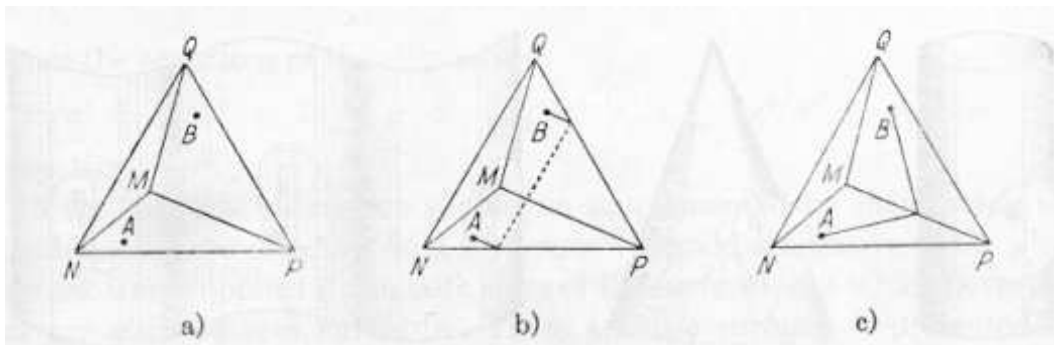

Figure 2.53: Tetrahedral Geodesics [305]

Property 69 (Tetrahedral Geodesics). *A geodesic is a generalization of a straight line which, in the presence of a metric, is defined to be the (locally) shortest path between two points as measured along the surface [305].*

For example, the tetrahedron $MNPQ$ of Figure 2.53(a) can be transformed into the equivalent planar net of Figure 2.54(a) by cutting the surface of the tetrahedron along the edges MN , MP and MQ , rotating the triangle MNP about the edge NP until it is in the same plane as the triangle NPQ , and then performing the analogous operations on the triangles MPQ and MQN . Now, in Figure 2.53(a), let A be the point of triangle MNP which lies one third of the way up from N on the perpendicular from N to MP ; and let B be the corresponding point in triangle MPQ . Then, we obtain the geodesic (and at the same time the shortest) line connecting A and B on the surface of the tetrahedron, shown in Figure 2.53(b), by simply drawing the dashed straight line connecting A to B in Figure 2.54(a). (The length of this geodesic is equal to the length of the edge NQ of the tetrahedron, which we take to be 1.) Figure 2.53(c) shows another geodesic connecting these same two points but which is longer. From Figure 2.54(b), the length of this geodesic is equal to $2\sqrt{3}/3 \approx 1.1547$. This net is obtained by cutting the surface of the tetrahedron along the edges MQ , MN and NP .

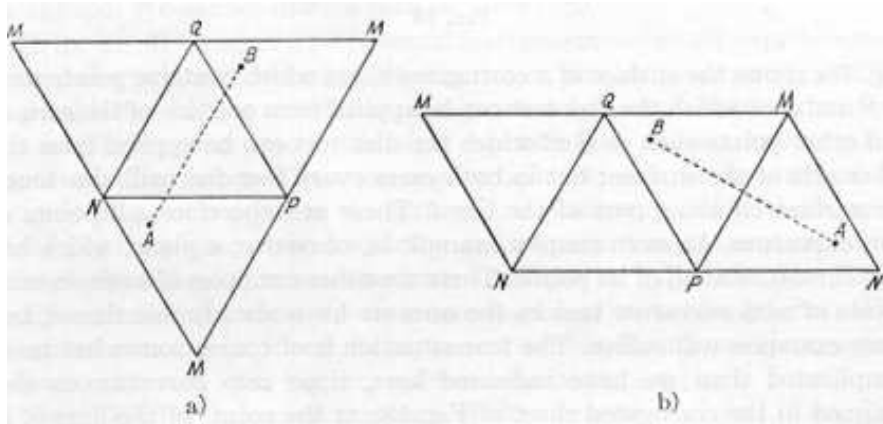

Figure 2.54: Transformation to Planar Net [305]

Property 70 (Malfatti's Problem). *In 1803, G. Malfatti proposed the problem of constructing three circles within a given triangle each of which is tangent to the other two and also to two sides of the triangle, as on the right of Figure 2.55 [231]. He assumed that this would provide a solution to the "marble problem": to cut out from a triangular prism, made of marble, three circular columns of the greatest possible volume (i.e., wasting the least possible amount of marble).*

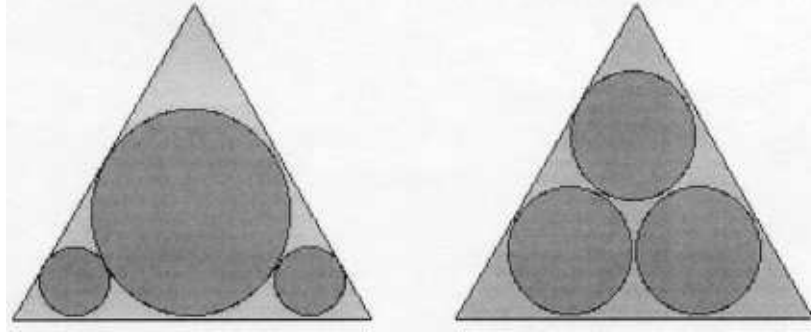

Figure 2.55: Malfatti's Problem [231]

In 1826, J. Steiner published, without proof, a purely geometrical construction while, in 1853, K. H. Schellbach published an elementary analytical solution [84]. Then, in 1929, H. Lob and H. W. Richmond showed that, for the equilateral triangle, the Malfatti circles did not solve the marble problem. The correct solution, shown on the left of Figure 2.55, fills $\frac{11\pi}{27\sqrt{3}} \approx 0.739$ of the triangle area while the Malfatti circles occupy only $\frac{\pi\sqrt{3}}{(1+\sqrt{3})^2} \approx 0.729$ of that area [2]. Whereas there is only this tiny 1% discrepancy for the equilateral triangle, in 1965, H. Eves pointed out that if the triangle is long and thin then the discrepancy can approach 2:1 [231]. In 1967, M. Goldberg demonstrated that the Malfatti circles never provide the solution to the marble problem [322]. Finally, in 1992, V. A. Zalgaller and G. A. Los gave a complete solution to the marble problem.

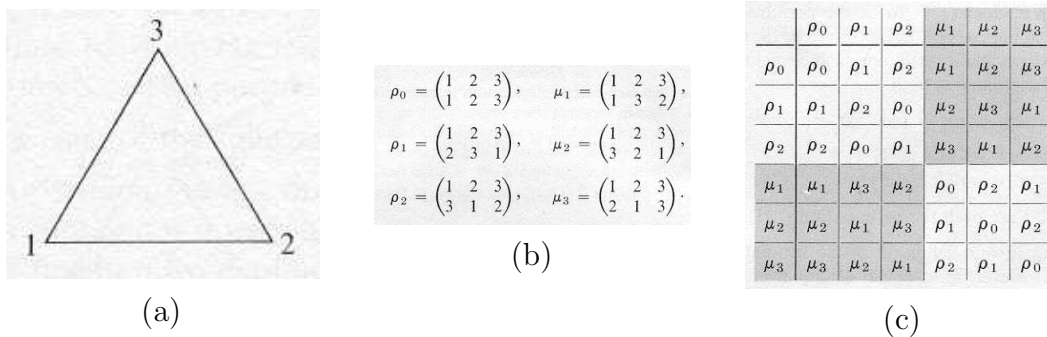

Figure 2.56: Group of Symmetries [108]

Property 71 (Group of Symmetries). *The equilateral triangle and the regular tiling of the plane which it generates, $\{3\}$, possess three lines of reflectional symmetry and three degrees of rotational symmetry as can be seen in Figure 2.56 [327].*

These isometries form the dihedral group of order 6, D_3 , and its group table also appears in Figure 2.56 where ρ_i stands for rotations and μ_i for mirror images in angle bisectors [108].

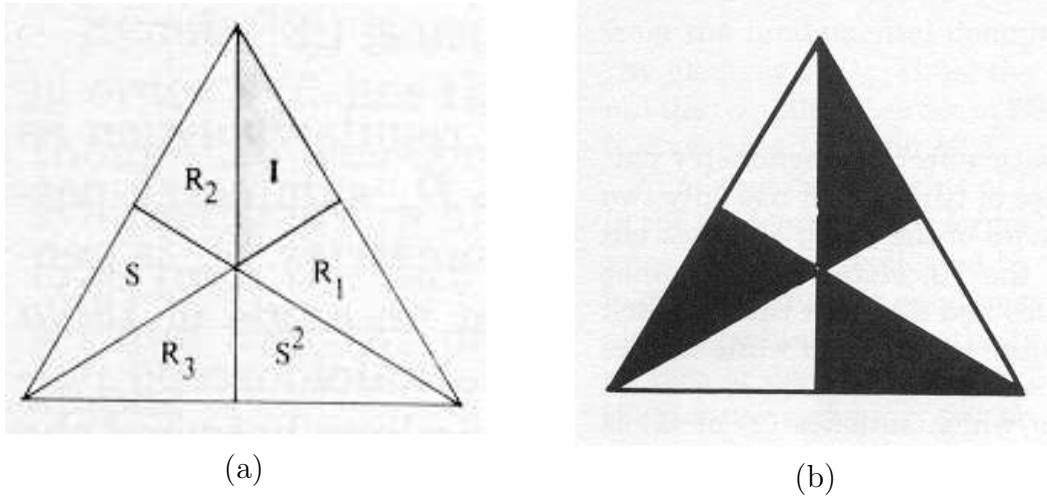

Figure 2.57: Color Symmetry: (a) Fundamental Domain. (b) Perfect Coloring. [190]

Property 72 (Perfect Coloring). *Starting from a fundamental domain (denoted by I in Figure 2.57(a)), a symmetry tiling of the equilateral triangular tile may be generated by operating on it with members of the group of isometries, D_3 .*

The five replicas so generated are labeled by the element of D_3 that maps it from the fundamental domain where, in our previous notation, $R_1 = \mu_1$, $R_2 = \mu_3$, $R_3 = \mu_2$, $S = \rho_2$, $S^2 = \rho_1$. A symmetry of a tiling that employs only two colors, say black and white, is called a two-color symmetry whenever each symmetry of the uncolored tiling either transforms all black tiles to black tiles and all white tiles to white tiles or transforms all black tiles to white tiles and all white tiles to black tiles. When every symmetry of the uncolored tiling is also a two-color symmetry, the coloring is called perfect. I.e., in a perfect coloring, each symmetry of the uncolored tiling simply induces a permutation of the colors in the colored tiling. A perfect coloring of the equilateral triangular tile is on display in Figure 2.57(b) [190].

Property 73 (Fibonacci Triangle). *Shade in a regular equilateral triangular lattice as shown in Figure 2.58 so that a rhombus (light) lies under each trapezoid (dark) and vice versa. Then, the sides of successive rhombi form a Fibonacci sequence $(1, 1, 2, 3, 5, 8, \dots)$ and the top, sides and base of each trapezoid are three consecutive Fibonacci numbers [315].*

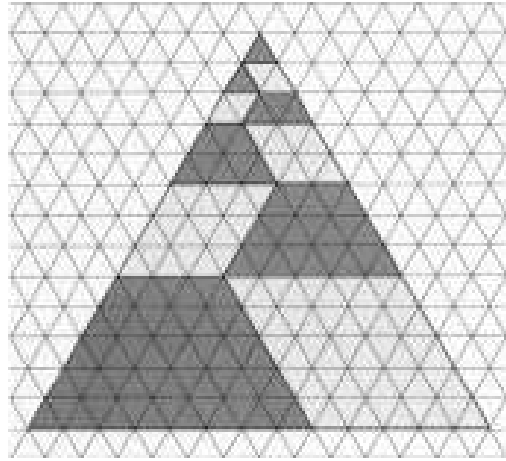

Figure 2.58: Fibonacci Triangle [315]

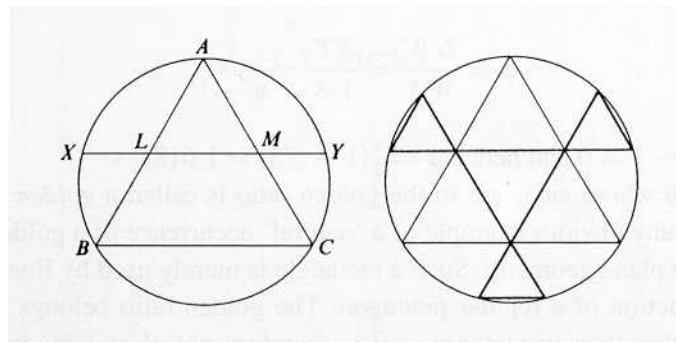

Figure 2.59: Golden Ratio [253]

Property 74 (Golden Ratio). *With reference to Figure 2.59 left, let ABC be an equilateral triangle inscribed in a circle, let L and M be the midpoints of AB and AC , respectively, and let LM meet the circle at X and Y as shown; then, $LM/MY = \phi$ where $\phi = (1 + \sqrt{5})/2$ is the golden ratio (limiting ratio of successive Fibonacci numbers) [253]. The pleasing design in Figure 2.59 right may be readily produced, in which the ratio of the sides of the larger to the smaller triangles is equal to ϕ .*

This intriguing result was first observed by George Odom, a resident of the Hudson River Psychiatric Center, in the early 1980s [254, p. 10]. Upon communicating it to the late H. S. M. Coxeter, it was submitted to the *American Mathematical Monthly* as Problem E3007, Vol. 90 (1983), p. 482 with the solution appearing in Vol. 93 (1986), p. 572.

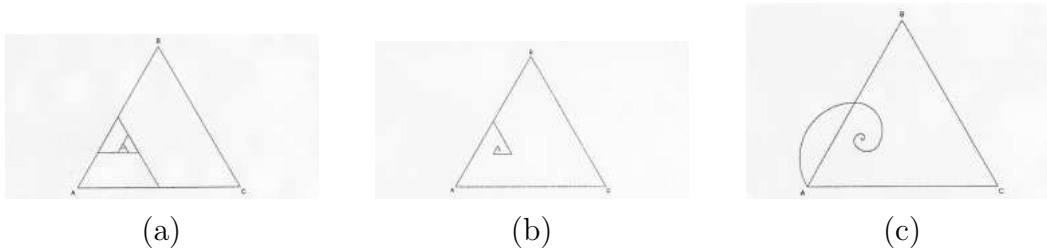

Figure 2.60: (a) Bination of Equilateral Triangle. (b) Male Equilateral Spiral. (c) Female Equilateral Spiral. [83]

Property 75 (Equilateral Spirals). *E. P. Doolan has introduced the notion of equilateral spirals [83].*

Successive subdivision of an equilateral triangle by systematically connecting edge midpoints, as portrayed in Figure 2.60(a), is called (clockwise) bination. (Gazalé [139, p. 111] calls the resulting configuration a “whorled equilateral triangle”.) Retention of the edge counterclockwise to the new edge produced at each stage produces a (clockwise) male equilateral spiral (Figure 2.60(b)). Replacement of each edge of such a male equilateral spiral by the arc of the circumcircle subtended by that edge produces the corresponding (clockwise) female equilateral spiral (Figure 2.60(c)).

Doolan has shown that the female equilateral spiral is in fact \mathcal{C}^1 . Moreover, both the male and female equilateral spirals are geometric in the sense that, for a fixed radius emanating from the spiral center, the intersections with the spiral are at a constant angle. Note that this is distinct from equiangularity in that this angle is different for different radii. In addition, he has investigated the “sacred geometry” of these equilateral spirals and shown how to construct them with only ruler and compass.

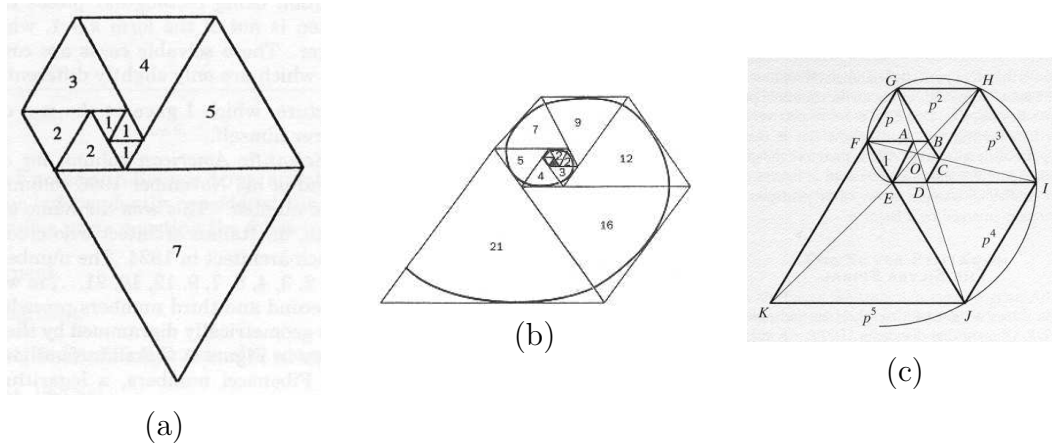

Figure 2.61: Padovan Spirals: (a) Padovan Whorl [138]. (b) Inner Spiral [293]. (c) Outer Spiral [139].

Property 76 (Padovan Spirals). *Reminiscent of the Fibonacci sequence, the Padovan sequence is defined as 1, 1, 1, 2, 2, 3, 4, 5, 7, 9, 12, 16, 21, . . . , where each number is the sum of the second and third numbers preceding it [138].*

The ratio of successive terms of this sequence approaches the plastic number, $p = \sqrt[3]{\frac{1}{2} + \frac{1}{6}\sqrt{\frac{23}{3}}} + \sqrt[3]{\frac{1}{2} - \frac{1}{6}\sqrt{\frac{23}{3}}} \approx 1.324718$, which is the real solution of $p^3 = p + 1$ [139]. The Padovan triangular whorl [139] is formed from the Padovan sequence as shown in Figure 2.61(a). Note that each triangle shares a side with two others thereby giving a visual proof that the Padovan sequence also satisfies the recurrence relation $p_n = p_{n-1} + p_{n-5}$. If one-third of a circle is inscribed in each triangle, the arcs form the elegant spiral of Figure 2.61(b) which is a good approximation to a logarithmic spiral [293]. Beginning with a gnomon composed of a “plastic pentagon” ($ABCDE$ in Figure 2.61(c)) with sides in the ratio $1 : p : p^2 : p^3 : p^4$, if we add equilateral triangles that grow in size by a factor of p , then a truly logarithmic spiral is so obtained [139].

Property 77 (Perfect Triangulation). *In 1948, W. T. Tutte proved that it is impossible to dissect an equilateral triangle into smaller equilateral triangles all of different sizes (orientation ignored) [309]. However, if we distinguish between upwardly and downwardly oriented triangles then such a “perfect” tiling is indeed possible [310].*

Figure 2.62, where the numbers indicate the size (side length) of the components in units of a primitive equilateral triangle, shows a dissection into 15 pieces, which is believed to be the lowest order possible. E. Buchman [35] has extended Tutte’s method of proof to conclude that no planar convex region can be tiled by unequal equilateral triangles. Moreover, he has shown that



Figure 2.62: Perfect Triangulation [310]

any nonequilateral triangle can be tiled by smaller unequal triangles similar to itself.

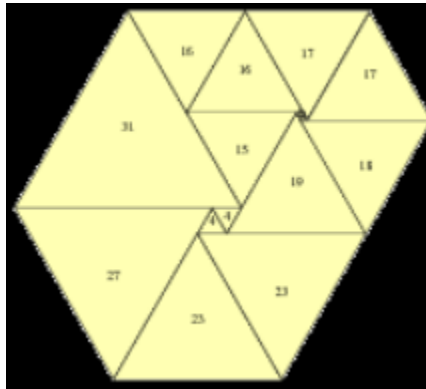

Figure 2.63: Convex Tilings [294]

Property 78 (Convex Tilings). *In 1996, R. T. Wainwright posed the question: What is the largest convex area that can be tiled with a given number of equilateral triangles whose sides are integers, where, to avoid trivially scaling up the size of a given tiling, the sizes of the tiles are further constrained to have no overall common divisor [294]?*

The best known such tiling with 15 equilateral triangles is shown in Figure 2.63 and has an area of 4,782 etus which is a considerable improvement over the minimum order perfect triangulation with area of 1,374 etus.

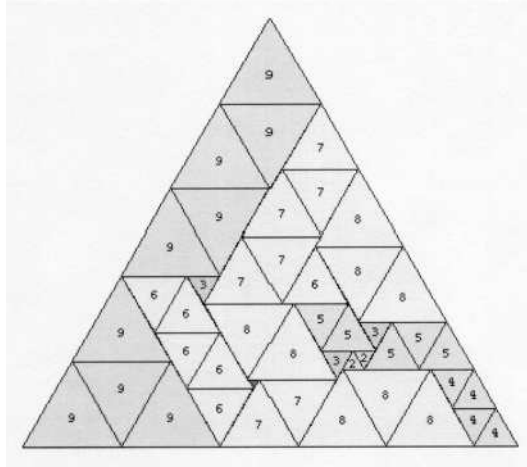

Figure 2.64: Partridge Tiling [162]

Property 79 (Partridge Tiling). *A partridge tiling of order n of an equilateral triangle is composed of 1 equilateral triangle of side 1, 2 equilateral triangles of side 2, and so on, up to n equilateral triangles of side n [162].*

The *partridge number* of the equilateral triangle is defined to be the smallest value of n for which such a tiling is possible. W. Marshall discovered the partridge tiling of Figure 2.64 and P. Hamlyn showed that this is indeed the smallest possible, and so the equilateral triangle has a partridge number of 9 [162].

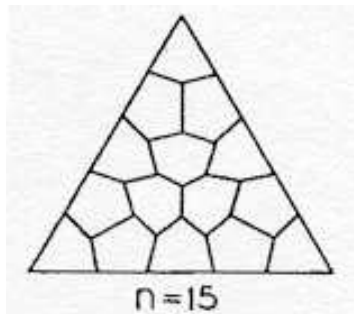

Figure 2.65: Partition of an Equilateral Triangle [149]

Property 80 (Partitions of an Equilateral Triangle). Let T denote a closed unit equilateral triangle. For a fixed integer n , let d_n denote the infimum of all those x for which it is possible to partition T into n subsets, each subset having a diameter not exceeding x . Recall that the diameter of a plane set A is given by $d(A) = \sup_{a,b \in A} \rho(a,b)$ where $\rho(a,b)$ is the Euclidean distance between a and b . R. L. Graham [149] has determined d_n for $1 \leq n \leq 15$. Figure 2.65 gives an elegant partition of T into 15 sets each having diameter $d_{15} = 1/(1 + 2\sqrt{3})$.

Property 81 (Dissecting a Polygon into Nearly-Equilateral Triangles). Every polygon can be dissected into acute triangles. On the other hand, a polygon P can be dissected into equilateral triangles with (interior) angles arbitrarily close to $\pi/3$ radians if and only if all of the angles of P are multiples of $\pi/3$. For every other polygon, there is a limit to how close it can come to being dissected into equilateral triangles [64, pp. 89-90].

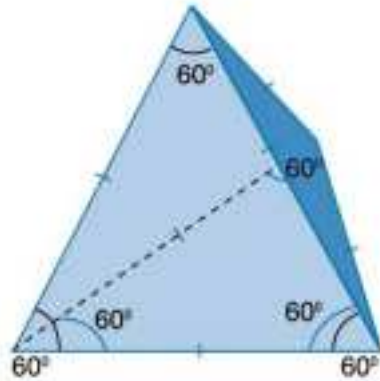

Figure 2.66: Regular Simplex [60]

Property 82 (Regular Simplex). A regular simplex is a generalization of the equilateral triangle to Euclidean spaces of arbitrary dimension [60]. Given a set of $n + 1$ points in \mathcal{R}^n which are pairwise equidistant (distance = d), an n -simplex is their convex hull.

A 2-simplex is an equilateral triangle, a 3-simplex is a regular tetrahedron (shown in Figure 2.66), a 4-simplex is a regular pentatope and, in general, an n -simplex is a regular polytope [60]. The convex hull of any nonempty proper subset of the given $n + 1$ mutually equidistant points is itself a regular simplex of lower dimension called an m -face. The $n + 1$ 0-faces are called vertices, the $\frac{n(n+1)}{2}$ 1-faces are called edges, and the $n + 1$ $(n - 1)$ -faces are called facets.

In general, the number of m -faces is equal to $\binom{n+1}{m+1}$ and so may be found

in column $m + 1$ of row $n + 1$ of Pascal's triangle. A regular n -simplex may be constructed from a regular $(n - 1)$ -simplex by connecting a new vertex to all of the original vertices by an edge of length d . A regular n -simplex is so named because it is the simplest regular polytope in n dimensions.

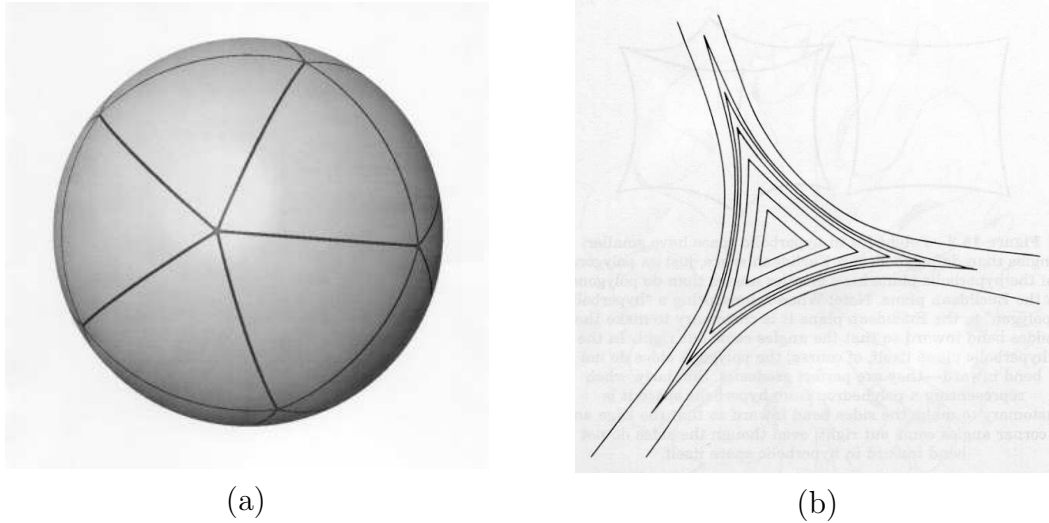

Figure 2.67: Non-Euclidean Equilateral Triangles: (a) Spherical. (b) Hyperbolic. [318]

Property 83 (Non-Euclidean Equilateral Triangles). *Figure 2.67 displays examples of non-Euclidean equilateral triangles.*

On a sphere, the sum of the angles in any triangle always exceeds π radians. On the unit sphere (with constant curvature $+1$ and area 4π), the area of an equilateral triangle, A , and one of its three interior angles, θ , satisfy the relation $A = 3\theta - \pi$ [318]. Thus, $\lim_{A \rightarrow 0} \theta = \pi/3$. The largest equilateral triangle, corresponding to $\theta = \pi$, encloses a hemisphere with its three vertices equally spaced along a great circle. I.e., $\lim_{A \rightarrow 2\pi} \theta = \pi$. Figure 2.67(a) shows a spherical tessellation by the 20 equilateral triangles, corresponding to $\theta = 2\pi/5$ and $A = \pi/5$, associated with an inscribed icosahedron. On a hyperbolic plane, the sum of the angles in any triangle is always smaller than π radians. On the standard hyperbolic plane, \mathcal{H}^2 , (with constant curvature -1), the area and interior angle of an equilateral triangle satisfy the relation $A = \pi - 3\theta$ [318]. Once again, $\lim_{A \rightarrow 0} \theta = \pi/3$. Observe the peculiar fact that an equilateral triangle in the standard hyperbolic plane (which is unbounded!) can never have an area exceeding π . This seeming conundrum is resolved by reference to Figure 2.67(b) where a sequence of successively larger equilateral hyperbolic triangles are represented in the Euclidean plane. Note that, as the sides of the triangle become unbounded, the angles approach zero while the area remains bounded. I.e., $\lim_{A \rightarrow \pi} \theta = 0$.

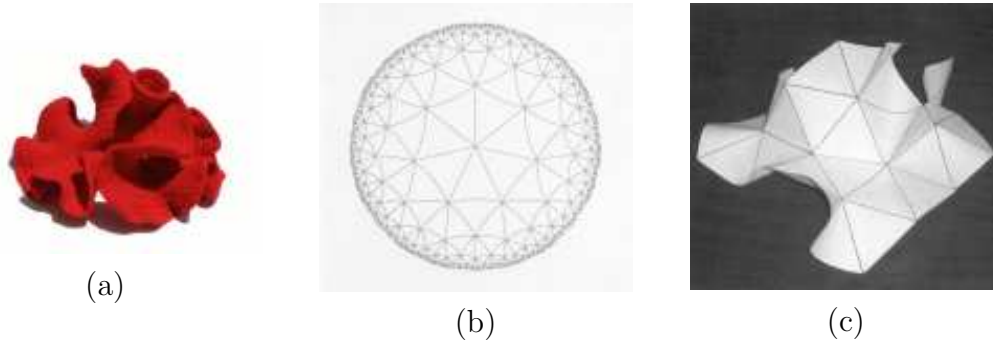

Figure 2.68: The Hyperbolic Plane: (a) Embedded Patch [302]. (b) Poincaré Disk. (c) Thurston Model [20]. [138]

Property 84 (The Hyperbolic Plane). *The crochet model of Figure 2.68(a) displays a patch of \mathcal{H}^2 embedded in \mathcal{R}^3 [302].*

As shown in Figure 2.68(b), it may also be modeled by the Poincaré disk whose geodesics are either diameters or circular arcs orthogonal to the boundary [33]. In this figure, the disk has been tiled by equilateral hyperbolic triangles meeting 7 at a vertex. This tiling ultimately led to the Thurston model of the hyperbolic plane shown in Figure 2.68(c) [20]. In this model, 7 Euclidean equilateral triangles are taped together at each vertex so as to provide novices with an intuitive feeling for hyperbolic space [318]. However, it is important to note that the Thurston model can be misleading if it is not kept in mind that it is but a qualitative approximation to \mathcal{H}^2 [20].

Property 85 (The Minkowski Plane). *In 1975, L. M. Kelly proved the conjecture of M. M. Day to the effect that a Minkowski plane with a regular dodecagon as unit circle satisfies the norm identity [192]:*

$$\|x\| = \|y\| = \|x - y\| = 1 \Rightarrow \|x + y\| = \sqrt{3}.$$

Stated more geometrically, the medians of an equilateral triangle of side length s are of length $\frac{\sqrt{3}}{2} \cdot s$ just as they are in the Euclidean plane. Midpoint in this context is interpreted vectorially rather than metrically.

Property 86 (Mappings Preserving Equilateral Triangles). *Sikorska and Szostok [281] have shown that if E is a finite-dimensional Euclidean space with $\dim E \geq 2$ then $f : E \rightarrow E$ is measurable and preserves equilateral triangles implies that it is a similarity transformation (an isometry multiplied by a positive constant).*

Since such a similarity transformation preserves every shape, this may be paraphrased to say that if a measurable function preserves a single shape, i.e. that of the equilateral triangle, then it preserves all shapes. In [282], they extend this result to normed linear spaces.

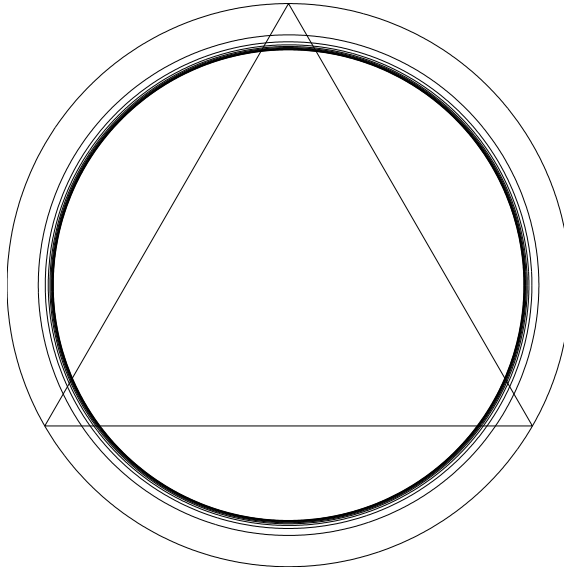

Figure 2.69: Delahaye Product

Property 87 (Delahaye Product). *In his Arithmetica Infinitorum (1655), John Wallis presented the infinite product representation*

$$\frac{\pi}{2} = \frac{2}{1} \cdot \frac{2}{3} \cdot \frac{4}{3} \cdot \frac{4}{5} \cdot \frac{6}{5} \cdot \frac{6}{7} \cdot \frac{8}{7} \cdot \frac{8}{9} \cdots$$

In 1997, Jean-Paul Delahaye [74, p. 205] presented the related infinite product

$$\frac{2\pi}{3\sqrt{3}} = \frac{3}{2} \cdot \frac{3}{4} \cdot \frac{6}{5} \cdot \frac{6}{7} \cdot \frac{9}{8} \cdot \frac{9}{10} \cdot \frac{12}{11} \cdot \frac{12}{13} \cdots$$

The presence of π together with $\sqrt{3}$ suggests that a relationship between the circle and the equilateral triangle may be hidden within this formula.

We may disentangle these threads as follows. The left-hand-side expression, $\frac{p_R}{p} = \frac{2\pi}{3\sqrt{3}}$, is the ratio of the perimeter of the circumcircle to the perimeter of the equilateral triangle. Introducing the scaling parameters $\sigma_k := \frac{\sqrt{(3k-1)(3k+1)}}{3k}$, Delahaye's product may be rewritten as

$$\lim_{k \rightarrow \infty} \frac{p_R \cdot \sigma_1^2 \cdot \sigma_2^2 \cdots \sigma_k^2 \cdots}{p} = 1.$$

Thus, if we successively shrink the circumcircle by multiplying its radius by the factors, σ_k^2 ($k = 1, \dots, \infty$), then the resulting circles approach a limiting position where the perimeter of the circle coincides with that of the equilateral triangle (Figure 2.69).

Property 88 (Grunsky-Motzkin-Schoenberg Formula). *Suppose that $f(z)$ is analytic on the equilateral triangle, T , with vertices at $1, w, w^2$ where $w := \exp(2\pi i/3)$. Then [69, p. 129],*

$$\int \int_T f''(z) \, dx dy = \frac{\sqrt{3}}{2} \cdot [f(1) + wf(w) + w^2 f(w^2)].$$

While this chapter has certainly made a strong case for the mathematical richness associated with the equilateral triangle, it runs the risk of leaving the reader with the impression that it has only theoretical and aesthetic value or, at best, is useful only within Mathematics itself. Nothing could be further from the truth! In the next chapter, I will present a sampling of applications of the equilateral triangle which have been selected to provide a feel for the diversity of practical uses of the equilateral triangle for comprehending the world about us that the human race has uncovered (so far).

Chapter 3

Applications of the Equilateral Triangle

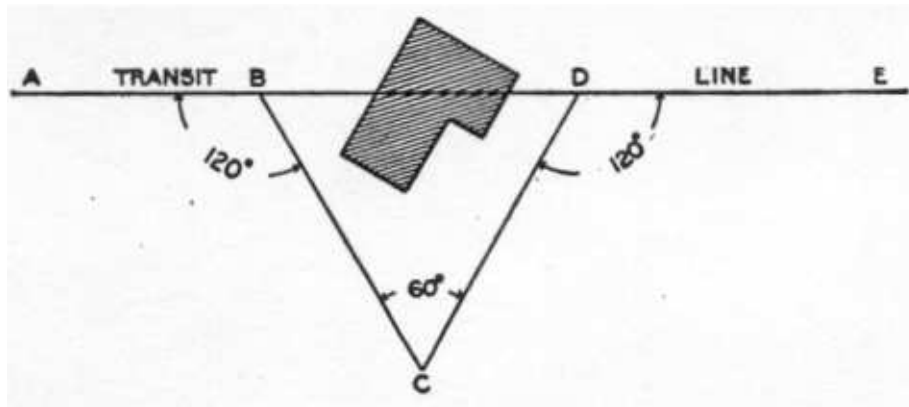

Figure 3.1: Equilateral Triangle Method in Surveying [34]

Application 1 (Surveying). *In surveying, the Equilateral Triangle Method [34] is used to measure around obstacles.*

With reference to Figure 3.1, point B is set on the transit line as near the obstacle as practicable but so that a line \overline{BC} at 60° with the transit line can be run out. The instrument is then set up at B , backsighted on A , and an angle of 120° laid off. The line \overline{BC} is made long enough so that, when the instrument is set up at C and 60° is laid off from it, \overline{CD} will lie outside the obstacle. \overline{BC} is measured and \overline{CD} is made equal to \overline{BC} . If now the instrument is set up at D and angle $\angle CDE$ laid off equal to 120° then the line \overline{DE} is the continuation of the original transit line and $\overline{BD} = \overline{BC}$.



Figure 3.2: North American Satellite Triangulation Network [53]

HOME BREW GPS (1575 Mhz) vertical blade monopole:
 sketch of construction details.

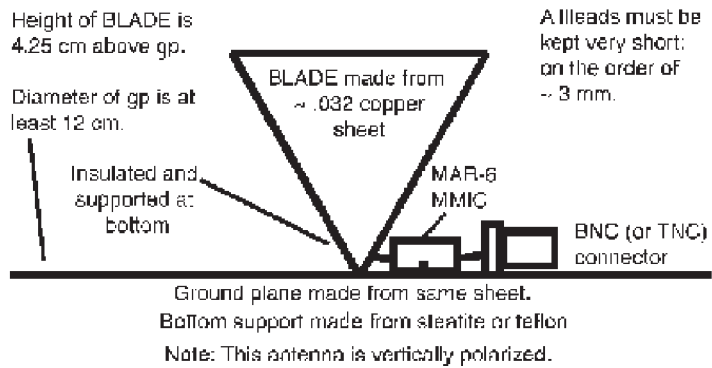

Figure 3.3: GPS Antenna [274]

Application 2 (Satellite Geodesy). *In satellite geodesy (the forerunner to today's GPS)[53], an equilateral triangle on the Earth (comprised of stations at Aberdeen, MD; Chandler, MN; and Greenville, MS) with sides roughly 900 miles long was first used in 1962 to verify the accuracy of the satellite triangulation concept.*

With reference to Figure 3.2, the U.S. Coast and Geodetic Survey used three specially designed ballistic cameras with associated electronic time synchronization systems to track the motion of the NASA ECHO I communications satellite. These three observation stations were tied to the existing triangulation network for the test. After several months of observations, it was concluded that this process offered precision comparable to, or better than, the existing conventional triangulation network. This allowed them to use this process to strengthen the North American Network which includes the continental United States and Alaska via Canada as well as the islands of Antigua and Bermuda.

Application 3 (GPS Antenna). *An equilateral triangular receiving antenna can be used in the Global Positioning System (GPS) [274].*

With reference to Figure 3.3, C. Scott has constructed a GPS receiving antenna based upon an equilateral triangular blade monopole design which approaches the broadband characteristics of a conical monopole. This in turn gives very broad resonance and reasonable impedance matching. As the aircraft receiver is not portable, this antenna is suitable for interfacing and debugging in the laboratory.

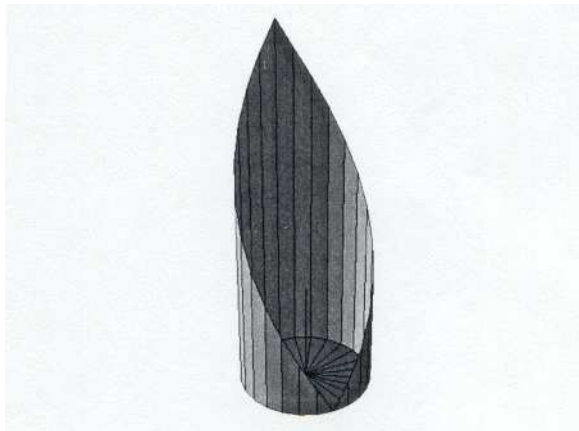

Figure 3.4: “Bat’s Ear” Antenna [106]

Application 4 (Biomimetic “Bat’s Ear” Antenna). *A biomimetic antenna in the shape of a bat’s ear may be constructed from an equilateral triangular conducting plate that is curved and the base electrically connected to a circular ground plane with a central monopole element [106].*

With reference to Figure 3.4, J. A. Flint [106] has shown that, for certain frequencies, this yields a higher gain and a radiation pattern with lower side lobes than the equivalent circular ground mounted monopole and that a good match can be retained at the coaxial input.

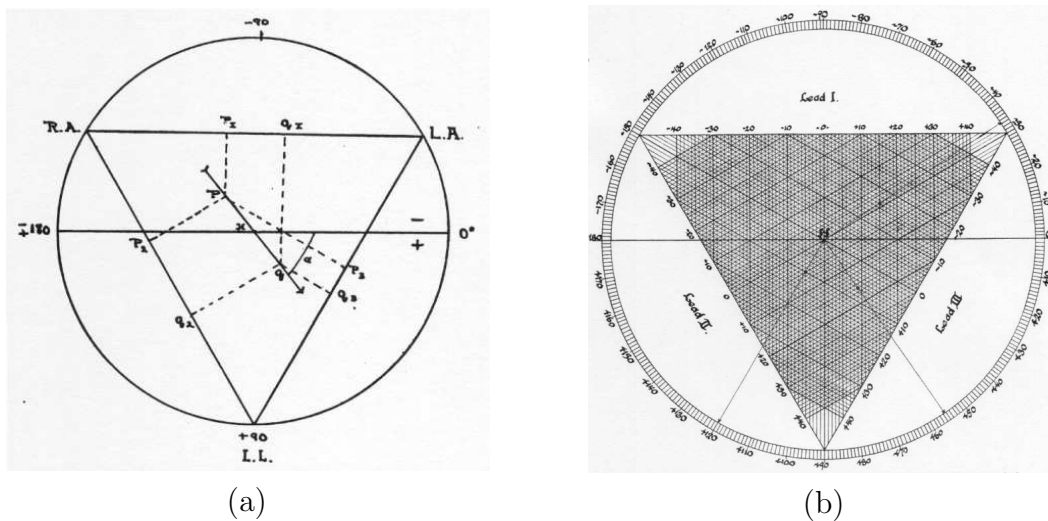

Figure 3.5: (a) Principle of the Equilateral Triangle in Electrocardiography. (b) Graphical Determination of the Electrical Axis of the Heart. [45]

Application 5 (Principle of the Equilateral Triangle in Electrocardiography). *Einthoven’s Triangle of Electrocardiography (Figure 3.5(a)), with vertices comprised of electrodes located on the left arm (LA), right arm (RA) and left leg (LL), is used to determine the electrical axis of the heart [45]. Normally, this electrical axis is oriented in a right shoulder to left leg direction. Any significant deviation of the electrical axis from this orientation can indicate ventricular hypertrophy (straining).*

The electrical activity of the heart can be described by the movement of an electrical dipole consisting of a negative and a positive charge separated by a variable distance. The directed line segment joining these two charges is called the cardiac vector. Its magnitude and direction can be described by three vectors along the edges of an equilateral triangle, each vector representing the potential difference, e_i , across electrical leads connecting the electrodes (e_1 : lead 1 from RA to LA; e_2 : lead 2 from RA to LL; e_3 : lead 3 from LA to LL).

The e_i are the projections of the cardiac vector onto the three sides of the Einthoven Triangle and $e_1 - e_2 + e_3 = 0$. Furthermore,

$$\tan \alpha = \frac{2e_2 - e_1}{e_1\sqrt{3}} = \frac{2e_3 + e_1}{e_1\sqrt{3}} = \frac{e_2 + e_3}{(e_2 - e_3)\sqrt{3}},$$

where α is the angle of inclination of the electrical axis of the heart. Along the corresponding edge of the triangle, a point a distance e_i (measured from the EKG) from the midpoint is marked off. The perpendiculars emanating from these three points meet at a point inside the triangle. The vector from the center of the Einthoven Triangle to this point of intersection represents the cardiac vector. Its angle of inclination is then easily read from the graphical device shown in Figure 3.5(b).

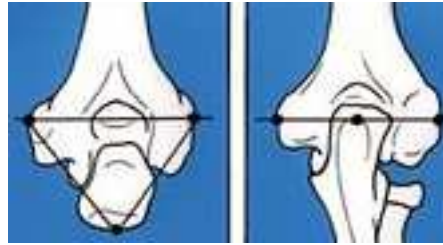

Figure 3.6: Human Elbow [88]

Application 6 (Human Elbow). *Three bony landmarks of the human elbow - the medial epicondyle, the lateral epicondyle, and the apex of the olecranon - form an approximate equilateral triangle when the elbow is flexed 90° , and a straight line when the elbow is in extension (Figure 3.6) [88].*

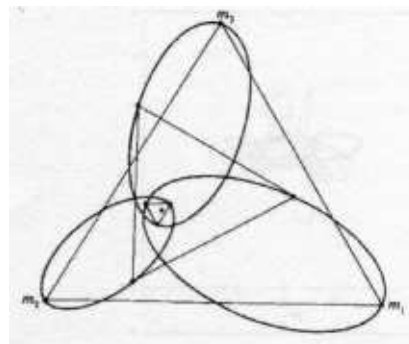

Figure 3.7: Lagrange's Equilateral Triangle Solution [171]

Application 7 (Lagrange’s Equilateral Triangle Solution (Three-Body Problem)). *The three-body problem requires the solution of the equations of motion of three mutually attracting masses confined to a plane. One of the few known analytical solutions is Lagrange’s Equilateral Triangle Solution [171].*

As illustrated in Figure 3.7 ($m_1 : m_2 : m_3 = 1 : 2 : 3$), the particles sit at the vertices of an equilateral triangle as this triangle changes size and rotates. Each particle follows an elliptical path of the same eccentricity but oriented at different angles with their common center of mass located at a focal point of all three orbits. The motion is periodic with the same period for all three particles. This solution is stable if and only if one of the three masses is much greater than the other two. However, very special initial conditions are required for such a configuration.

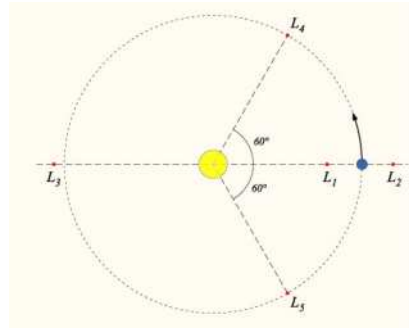

Figure 3.8: Lagrangian Points [1]

Application 8 (Lagrangian Points (Restricted Three-Body Problem)). *In the circular restricted three-body problem, one of the three masses is taken to be negligible while the other two masses assume circular orbits about their center of mass.*

There are five points (Lagrangian points, L-points, libration points) where the gravitational forces of the two large bodies exactly balance the centrifugal force felt by the small body [1]. An object placed at one of these points would remain in the same position relative to the other two. Points L_4 and L_5 are located at the vertices of equilateral triangles with base connecting the two large masses; L_4 lies 60° ahead and L_5 lies 60° behind as illustrated in Figure 3.8. These two Lagrangian Points are (conditionally) stable under small perturbations so that objects tend to accumulate in the vicinity of these points. The so-called Trojan asteroids are located at the L_4 and L_5 points of the Sun-Jupiter system. Furthermore, the Saturnian moon Tethys has two smaller moons, Telesto and Calypso, at its L_4 and L_5 points while the Saturn-Dione L_4 and L_5 points hold the small moons Helene and Polydeuces [296, p. 222].

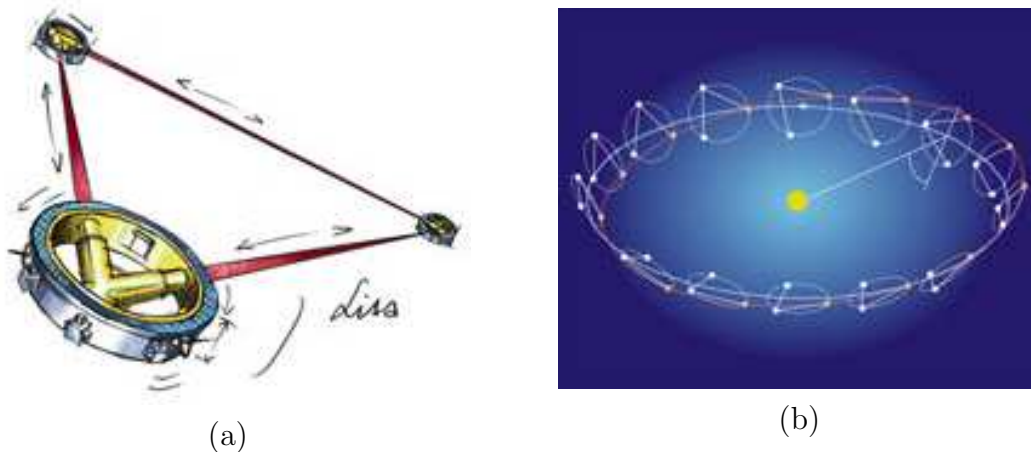

Figure 3.9: (a) LISA (Laser Interferometer Space Antenna). (b) The LISA Constellation's Heliocentric Orbit. [117]

Application 9 (LISA and Gravitational Waves). *Launching in 2020 at the earliest, LISA (Laser Interferometer Space Antenna) [117] will overtake the Large Hadron Collider as the world's largest scientific instrument.*

Einstein's General Theory of Relativity predicts the presence of gravitational waves produced by massive objects, such as black holes and neutron stars, but they are believed to be so weak that they have yet to be detected. This joint project of ESA and NASA to search for gravitational waves will consist of three spacecraft arranged in an equilateral triangle, 5 million kilometers (3.1 million miles or $1/30$ of the distance to the Sun) on each side, that will tumble around the Sun 20° behind Earth in its orbit (Figure 3.9(a)). The natural free-fall orbits of the three spacecraft around the Sun will maintain this triangular formation. The plane of the LISA triangle will be inclined at 60° to the ecliptic, and the triangle will appear to rotate once around its center in the course of a year's revolution around the Sun (Figure 3.9(b)). Each spacecraft will house a pair of free-floating cubes made of a gold-platinum alloy and the distance between the cubes in different spacecraft will be monitored using highly accurate laser-based techniques. In this manner, it will be possible to detect minute changes to the separation of the spacecraft caused by passing gravitational waves.

Application 10 (Ionocraft ("Lifter")). *An ionocraft or ion-propelled aircraft (a.k.a. "Lifter") is an electrohydrodynamic (EHD) device which utilizes an electrical phenomenon known as the Biefeld-Brown effect to produce thrust in the air, without requiring combustion or moving parts [101].*

The basics of such ion air propulsion were established by T. T. Brown in 1928 and were further developed into the ionocraft by Major A. P. de Seversky

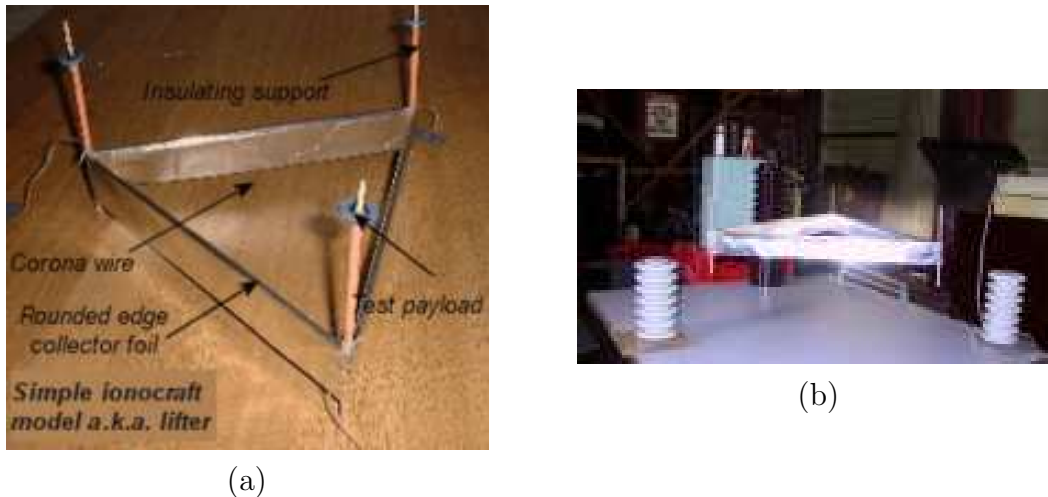

Figure 3.10: (a) Ionocraft (“Lifter”). (b) Levitating Lifter. [101]

in 1964. It utilizes two basic pieces of equipment in order to take advantage of the principle that electric current always flows from negative to positive: tall metal spikes that are installed over an open wire-mesh grid. High negative voltage is emitted from the spikes toward the positively charged wire grid, just like the negative and positive poles on an ordinary battery. As the negative charge leaves the spike arms, it pelts the surrounding air, putting a negative charge on some of the surrounding air particles. Such negatively charged air particles (ions) are attracted downward by the positively charged grid. In their path from the ion emitter to the collector grid, the ions collide with neutral air molecules - air particles without electric charge. These collisions thrust a mass of neutral air downward along with the ions. When they reach the grid, the negatively charged ions are trapped by the positively charged grid but the neutral air particles that got pushed along flow right through the open grid mesh, thus producing a downdraft beneath the ionocraft (ionic wind). The ionocraft rides on this shaft of air, getting its lift just like a helicopter. The simplest ionocraft is an equilateral triangular configuration (Figure 3.10(a)), popularly known as a Lifter, which can be constructed from readily available parts but requires high voltage for its successful operation. The Lifter works without moving parts, flies silently, uses only electrical energy and is able to lift its own weight plus an additional payload (Figure 3.10(b)).

Application 11 (Warren Truss). *The rigidity of the triangle [152] has been exploited in bridge design. The Warren truss (1848) [63] consists of longitudinal members joined only by angled cross-members which form alternately inverted equilateral triangular shaped spaces along its length (Figure 3.11).*

This ensures that no individual strut, beam or tie is subject to bending or torsional forces, but only to tension or compression. This configuration



Figure 3.11: Warren Truss [63]

combines strength with economy of materials and can therefore be relatively light. It is an improvement of the Neville truss which employs a spacing configuration of isosceles triangles. The first bridge designed in this way was constructed at London Bridge Station in 1850.

Application 12 (Flammability Diagram). *Flammability diagrams [334] show the regimes of flammability in mixtures of fuel, oxygen and an inert gas (typically nitrogen).*

The flammability diagram for methane appears in Figure 3.12. Prominent features are the air-line together with its intersections with the flammability region which determine the upper (UEL=upper explosive limit) and lower (LEL=lower explosive limit) flammability limits of methane in air. The nose of the flammability envelope determines the limiting oxygen concentration (LOC) below which combustion cannot occur.

Application 13 (Goethe's Color Triangle). *In the Goethe Color Triangle [145], the vertices of an equilateral triangle are labeled with the three primary pigments, blue (A), yellow (B) and red (C).*

The triangle is then further subdivided as in Figure 3.13 with the subdivisions grouped into primary (I), secondary (II) and tertiary (III) triangles/colors. The secondary triangle colors represent the mix of the two adjacent primary triangle colors and the tertiary triangle colors represent the mix of the adjacent primary color triangle and the non-adjacent secondary triangle color. Goethe's color psychology asserted that this triangle was a diagram of the human mind and he associated each of its colors with a human emotion. Subregions of the triangle are thus representative of a corresponding emotional state.

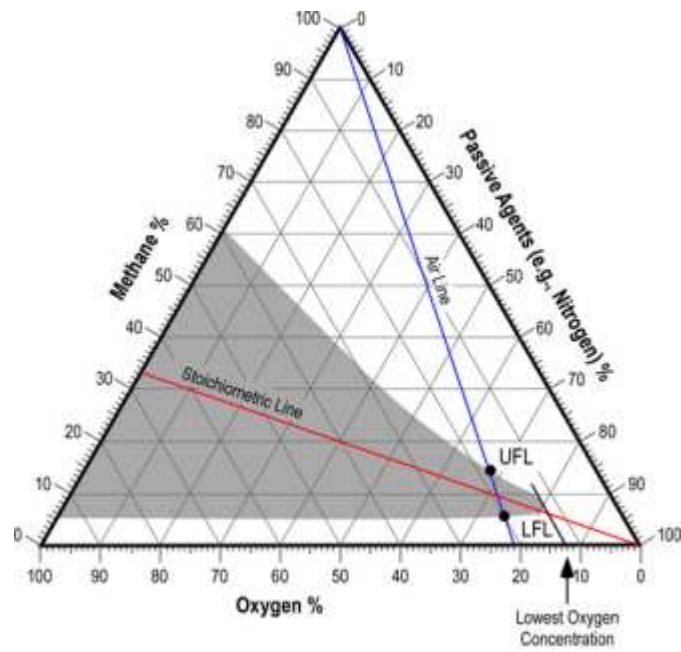

Figure 3.12: Flammability Diagram [334]

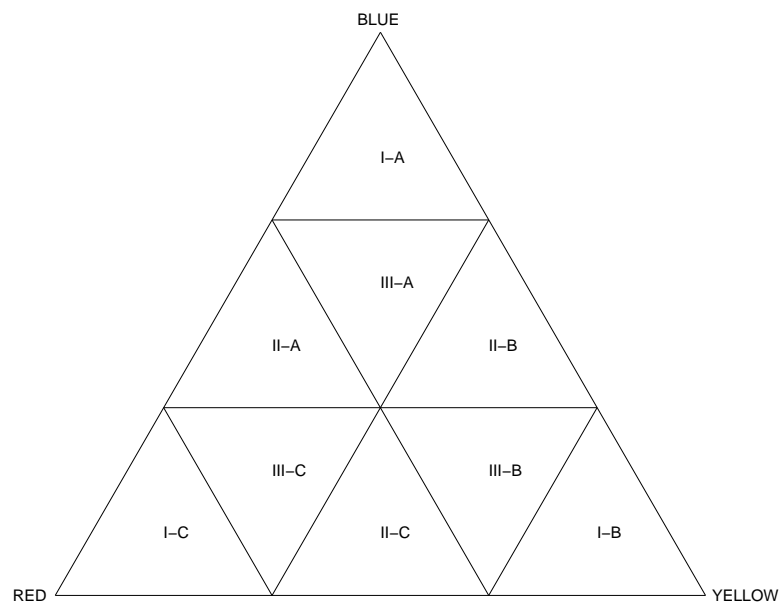

Figure 3.13: Goethe's Color Triangle [145]

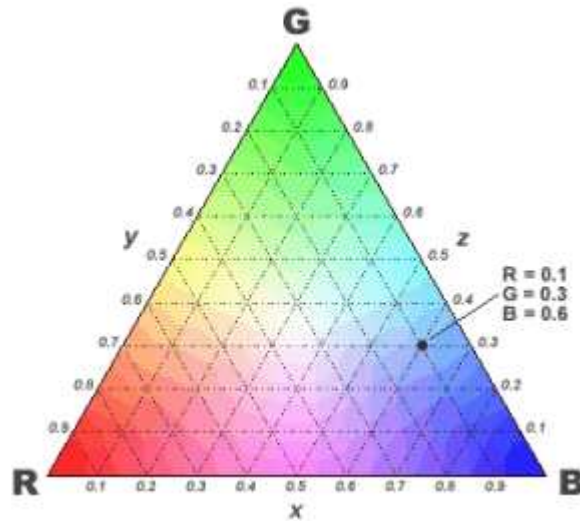

Figure 3.14: Maxwell's Color Triangle [5]

Application 14 (Maxwell's Color Triangle). *The Maxwell Color Triangle [5] is a ternary diagram of the three additive primary colors of light (red (R), green (G), blue (B)).*

As such, it displays the complete gamut of colors obtainable by mixing two or three of them together (Figure 3.14). At the center is the equal energy point representing true white. This triangle shows the quality aspect of psychophysical color called chromaticity which includes hue and saturation but not the quantity aspect comprised of the effective amount of light.

Application 15 (USDA Soil Texture Triangle). *The Soil Texture Triangle [72] is a ternary diagram of sand, silt and clay which is used to classify the texture class of a soil.*

The boundaries of the soil texture classes are shown in Figure 3.15. Landscapers and gardeners may then use this classification to determine appropriate soil ammendments, such as adding organic matter like compost, to improve the soil quality.

Application 16 (QFL Diagram). *Clastic sedimentary rock is composed of discrete fragments (clasts) of materials derived from other minerals. Such rock can be classified using the QFL diagram [79].*

This is a ternary diagram comprised of quartz (Q), feldspar (F) and lithic (sand) fragments (L). The composition and provenance of sandstone is directly related to its tectonic environment of formation (Figure 3.16).



Figure 3.15: Soil Texture Triangle [72]

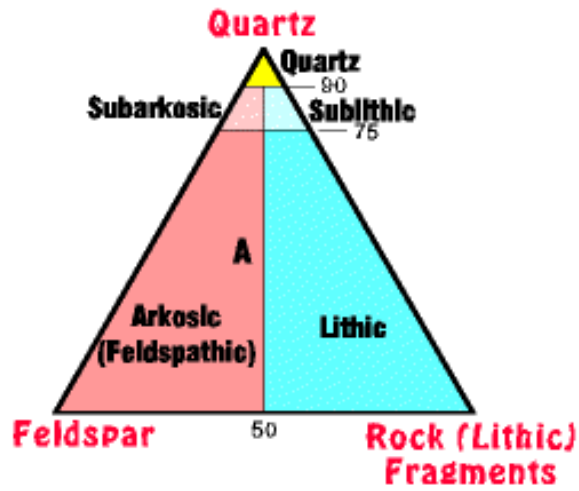

Figure 3.16: QFL (Clastic) Diagram [79]

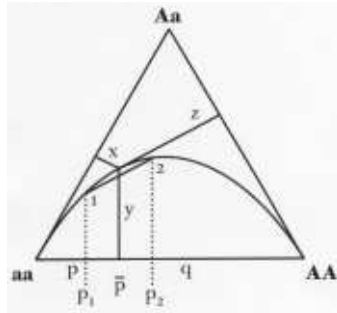

Figure 3.17: De Finetti Diagram (Genetics) [65]

Application 17 (De Finetti Diagram (Genetics)). *De Finetti diagrams [92] are used to display the genotype frequencies of populations where there are two alleles and the population is diploid.*

In Figure 3.17, the curved line represents the Hardy-Weinberg frequency as a function of p . The diagram may also be extended to demonstrate the changes that occur in allele frequencies under natural selection.

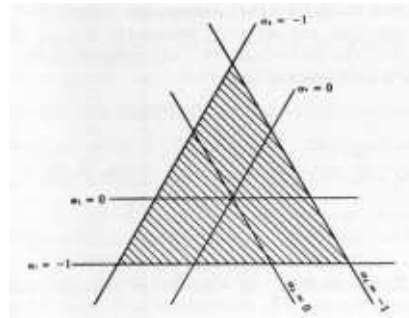

Figure 3.18: Fundamental Triangle (Game Theory) [312]

Application 18 (Fundamental Triangle (Game Theory)). *Von Neumann and Morgenstern [312] introduced the Fundamental Triangle (Figure 3.18) in their pathbreaking analysis of three-person game theory.*

The imputation vector $\vec{\alpha} = (\alpha_1, \alpha_2, \alpha_3)$ satisfies

$$\alpha_i \geq -1 \quad (i = 1, 2, 3); \quad \alpha_1 + \alpha_2 + \alpha_3 = 0.$$

Thus, the shaded region of Figure 3.18 may be coordinatized as a ternary diagram which can then be used to determine all solutions for essential zero-sum three-person games. Furthermore, it may be adapted for the analysis of essential nonzero-sum three-person games.

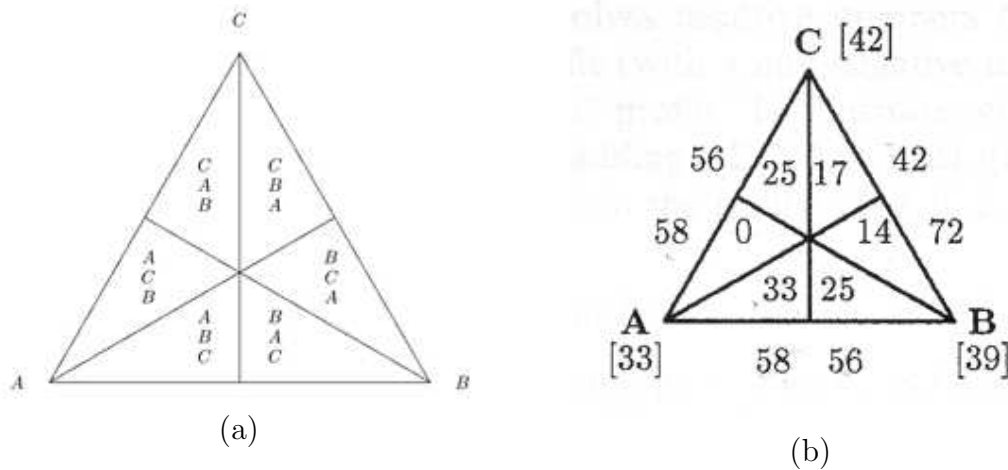

Figure 3.19: Representation Triangle: (a) Ranking Regions. (b) Voting Paradox. [261]

Application 19 (Representation Triangle (Voting Theory)). According to D. G. Saari [261], each of three candidates may be assigned to the vertex of an equilateral “representation triangle” which is then subdivided into six “ranking regions” by its altitudes (Figure 3.19(a)) [261].

Each voter ranks the three candidates. The number of voters of each type is then placed into the appropriate ranking region (Figure 3.19(b)). The representation triangle is a useful device to illustrate voting theory paradoxes and counterintuitive outcomes. The two regions adjacent to a vertex correspond to first place votes, the two regions adjacent to these second place votes, and the two most remote regions third place votes. Geometrically, the left-side of the triangle is closer to A than to B and so represents voters preferring A to B ; ditto for the five regions likewise defined. For the displayed example, C wins a plurality vote with 42 first place votes. In so-called Borda voting, where a first place vote earns two points, a second place vote earns one point and a third place vote earns no points, B wins with a Borda count of 128. In Condorcet voting, where the victor wins all pairwise elections, A is the Condorcet winner. So, who really won the election [261]?

Application 20 (Error-Correcting Code). The projective plane of order 2, which is modeled by an equilateral triangle together with its incircle and altitudes, is shown in Figure 3.20(a).

There are 7 points (numbered) and 7 lines (one of which is curved); each line contains three points and each point lies on three lines. This is also known as the Steiner triple-system of order 7 since each pair of points lies on exactly one line. The matrix representation is shown in Figure 3.20(b) where the rows

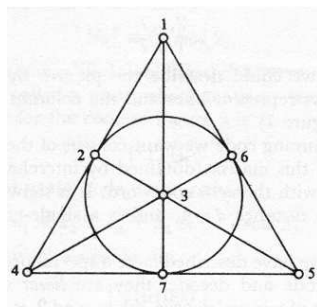

(a)

		Points						
		1	2	3	4	5	6	7
Lines	1	1	1	0	1	0	0	0
	2	0	1	1	0	1	0	0
	3	0	0	1	1	0	1	0
	4	0	0	0	1	1	0	1
	5	1	0	0	0	1	1	0
	6	0	1	0	0	0	1	1
	7	1	0	1	0	0	0	1

(b)

0	0	0	0	0	0	0	0
0	0	1	0	1	1	1	1
1	0	0	1	0	1	1	1
1	1	0	0	1	0	1	1
1	1	1	0	0	1	0	0
0	1	1	1	0	0	0	1
1	0	1	1	1	0	0	0
0	1	0	1	1	1	1	0

(c)

Figure 3.20: (a) Projective Plane of Order 2. (b) Binary Matrix Representation. (c) Hamming Code of Length 7. [286]

represent lines, the columns represent points and the presence of a 1 indicates that a point lies on a line or, equivalently, a line contains a point (0 otherwise). The Hamming code of length 7, which contains 8 codewords, is obtained by taking the complement of the rows of this matrix and appending the zero codeword (Figure 3.20(c)). It has minimum Hamming distance $d = 4$ and is a single-error-correcting code [286].

Application 21 (Equilateral Triangle Rule (Speaker Placement)). *Stereo playback assumes a symmetrical loudspeaker and listener arrangement with a 60° angle between the loudspeakers and corresponding to an equilateral triangular configuration (Figure 3.21) [208].*

Application 22 (Equilateral Triangular Microphone Placement). *Hioka and Hamada [173] have explored an algorithm for speaker direction tracking using microphones located at the vertices of an equilateral triangle (Figure 3.22).*

In teleconferencing and remote lecturing systems, speaker direction tracking is essential for focusing the desired speech signal as well as steering the camera to point at the speaker. For these applications, the accuracy should be spatially uniform for omni-directional tracking and, for practical purposes, a small number of microphones is desirable. Both of these objectives are achieved by the integrated use of three cross-spectra from the equilateral triangular microphone array. Computer simulations and experimental measurements have confirmed that this array possesses uniform omni-directional accuracy and does not lose track of the speaker even if he/she moves abruptly.

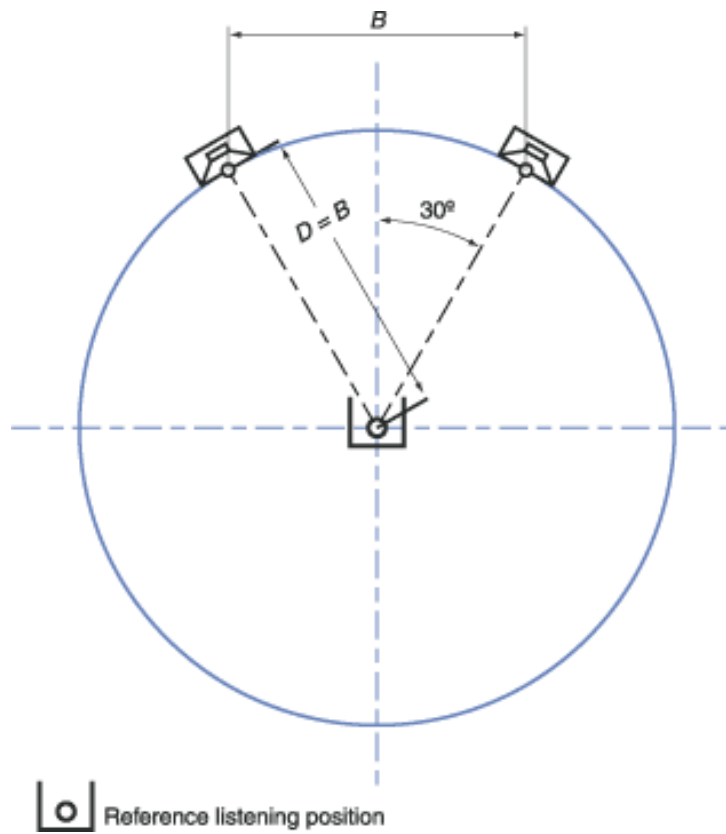

Figure 3.21: Equilateral Triangle Rule [280]

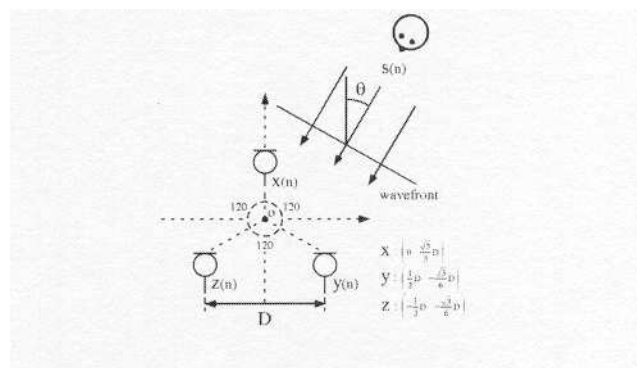

Figure 3.22: Equilateral Triangular Microphone Array [173]

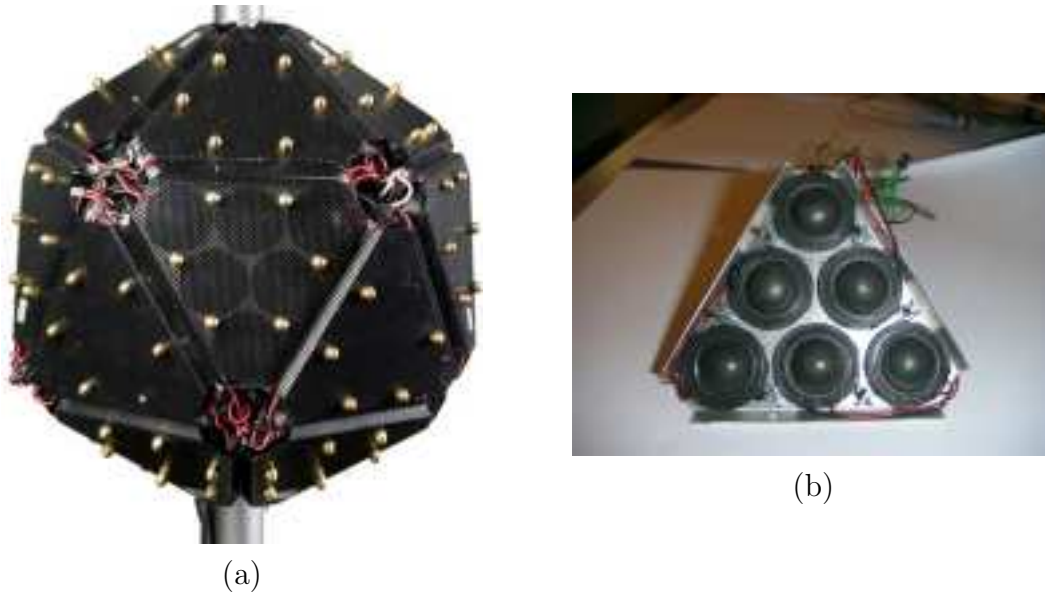

Figure 3.23: Loudspeaker Array: (a) Icosahedral Speaker. (b) Equilateral Triangle Array. [13]

Application 23 (Icosahedral Speaker). *The research team at The Center for New Music and Audio Technologies (CNMAT) of UC-Berkeley, in collaboration with Meyer Sound of Berkeley, California, has created a compact 120-channel approximately spherical loudspeaker for experiments with synthesis of acoustic signals with real-time programmable directional properties.*

These directional patterns can reproduce the complete radiative signature of natural instruments or explore new ideas in spatial audio synthesis. A special hybrid geometry is used that combines the maximal symmetry of a twenty-triangular-faceted icosahedron (Figure 3.23(a)) with the compact planar packing of six circles on an equilateral triangle (Figure 3.23(b) shows the resulting “billiard ball packing”.) [13].

Application 24 (Superconducting Sierpinski Gasket). *In 1986, Gordon et al. [147] reported on their experimental investigations of the properties of a superconducting Sierpinski gasket (SG) network in a magnetic field.*

Because of their dilational symmetry, statistical mechanical and transport problems are exactly solvable on these fractals. Moreover, study of the SG network is inherently interesting because of its lack of translational invariance and its anomalous (fractal) dimensionalities. The experimental gaskets (Figure 3.24) were of tenth order with elementary triangles of area $1.38 \mu\text{m}^2$ and produced excellent quantitative agreement with theoretical predictions.

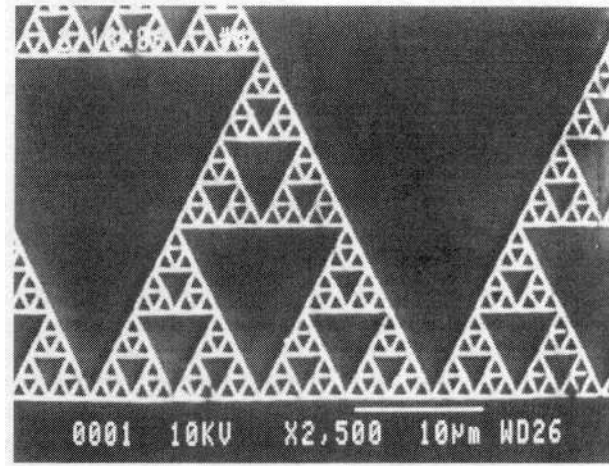

Figure 3.24: Superconducting Sierpinski Gasket [147]

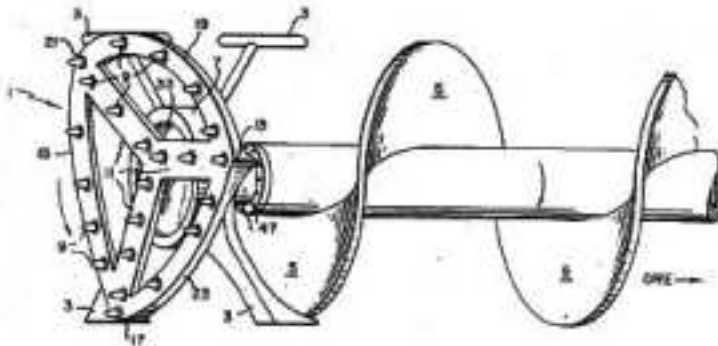

Figure 3.25: Square Hole Drill (U. S. Patent 4,074,778) [242]

Application 25 (Square Hole Drill). *In 1978, U. S. Patent 4,074,778 was granted for a “Square Hole Drill” based upon the Reuleaux triangle (Figure 3.25) [242].*

The resulting square has slightly rounded corners but achieves approximately 99% of the desired area. It was not the first such drill granted a patent: the Watts drill received U. S. Patent 1,241,176 in 1917!



Figure 3.26: Wankel Engine [303]

Application 26 (Wankel Engine). *The Wankel non-reciprocating engine (Figure 3.26) is a rotary internal combustion engine which has the shape of a Reuleaux triangle inscribed in a chamber, rather than the usual piston, cylinder and mechanical valves [303].*

This rotary engine, found in Mazda automobiles, has 40% fewer parts and thus far less weight. Within the Wankel rotor, three chambers are formed by the sides of the rotor and the wall of the housing. The shape, size, and position of the chambers are constantly altered by the rotation of the rotor.

Application 27 (Equilateral Triangular Anemometer). *Anemometers are used to measure either wind speed or air pressure, depending on the style of anemometer [186].*

The most familiar form, the cup anemometer, was invented in 1846 by J. T. R. Robinson and features four hemispherical cups arranged at 90° angles. An anemometer’s ability to measure wind speed is limited by friction along the axis of rotation and aerodynamic drag from the cups themselves. For this reason, more accurate anemometers feature only three cups arranged in an equilateral triangle. Modern ultrasonic anemometers, such as that shown



Figure 3.27: Ultrasonic Anemometer [317]

in Figure 3.27, have no moving parts. Instead, they employ bi-directional ultrasonic transducers which act as both acoustic transmitters and acoustic receivers. They work on the principle that, when sound travels against/with the wind, the total transit time is increased/reduced by an amount dependent upon the wind speed [317].

Application 28 (Natural Equilateral Triangles). *Mother Nature has an apparent fondness for equilateral triangles which is in evidence in Figure 3.28, where its manifestation in both (a) the nonliving and (b) the living worlds is on prominent display [54]. (See Appendix A for many more examples.)*

Application 29 (Equilateral Triangular Maps). *In 1913, B. J. S. Cahill of Oakland, California patented his butterfly map which is shown in Figure 3.29(a) [132].*

It is obtained by inscribing a regular octahedron in the Earth and then employing gnomonic projection, i.e. projection from the globe's center, onto its eight equilateral triangular faces [132]. However, with the highest face count (20) amongst regular polyhedra, the icosahedron has long been a favorite among cartographers. In 1943, distinguished Yale economist Irving Fisher published his Likeaglobe map which is shown in Figure 3.29(b). It is the product of gnomonic projection of the world to the twenty equilateral triangular faces of an inscribed icosahedron [132]. In 1954, R. Buckminster Fuller patented his Dymaxion Skyocean Projection World Map [113] which is

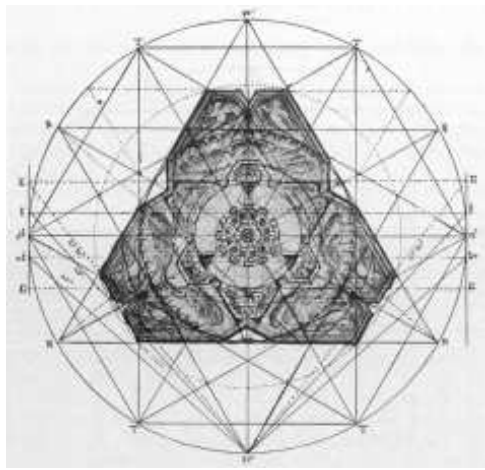

(a)

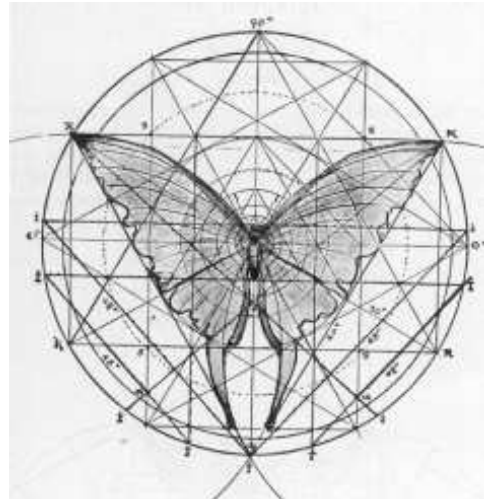

(b)

Figure 3.28: Natural Equilateral Triangles: (a) High Altitude Snow Crystal. (b) South American Butterfly Species. [54]

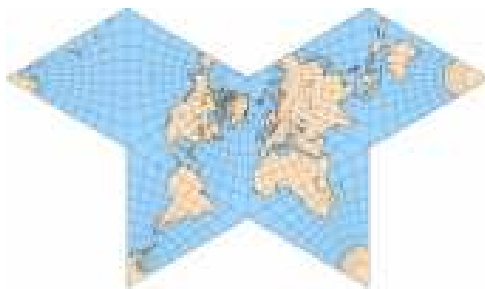

(a)



(b)

Figure 3.29: Equilateral Triangular Maps: (a) Cahill's Butterfly Map (Octahedron). (b) Fisher's Likeaglobe Map (Icosahedron). [132]

also based upon the icosahedron. It differs from Fisher's Likeaglobe in having the North and South poles on opposite faces at points slightly off center.

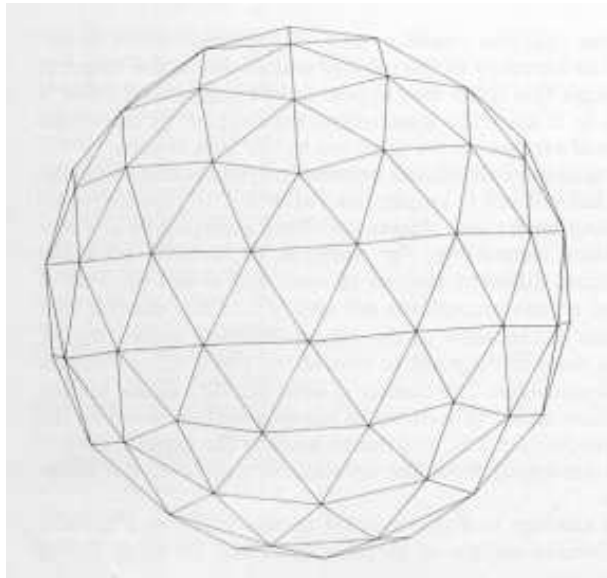

Figure 3.30: 3-Frequency Geodesic Dome [190]

Application 30 (Geodesic Dome). *A geodesic dome is a (portion of a) spherical shell structure based upon a network of great circles (geodesics) lying on the surface of a sphere that intersect to form triangular elements [190].*

Since the sphere encloses the greatest volume for a given surface area, it provides for economical design (largest amount of internal space and minimal heat loss due to decreased outer skin surface) and, because of its triangulated nature, it is structurally stable. In its simplest manifestation [190], the twenty triangular faces of an inscribed icosahedron are subdivided into equilateral triangles by partitioning each edge into n (the “frequency”) segments. The resulting vertices are then projected onto the surface of the circumscribing sphere. The projected triangles are no longer congruent but are of two varieties thereby producing vertices with a valence of either five or six. The resulting geodesic structure has 12 5-valent vertices, $10(n^2 - 1)$ 6-valent vertices, $30n^2$ edges and $20n^2$ faces [152]. See Figure 3.30 for the case $n = 3$. The geodesic sphere may now be truncated to produce a dome of the desired height. Such geodesic domes were popularized in the architecture of R. Buckminster Fuller [113]. About 1960, biochemists employed electron microscopy to discover that some viruses have recognizable icosahedral symmetry and look like tiny geodesic domes [59].

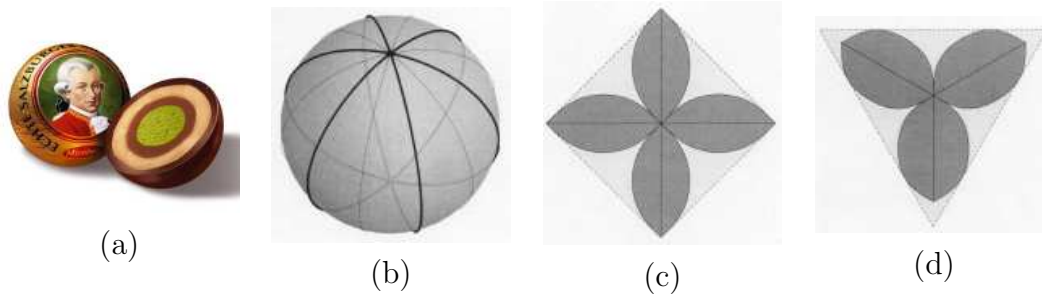

Figure 3.31: Sphere Wrapping: (a) Mozartkugel. (b) Petals. (c) Square Wrapping. (d) Equilateral Triangular Wrapping. [75]

Application 31 (Computational Confectionery (Optimal Wrapping) [75]). Mozartkugel (“Mozart sphere”) is a fine Austrian confectionery composed of a sphere with a marzipan core (sugar and almond meal), encased in nougat or praline cream, and coated with dark chocolate (Figure 3.31(a)).

It was invented in 1890 by Paul Fürst in Salzburg (Mozart’s birthplace) and about 90 million of them are still made and consumed world-wide each year. Each spherical treat is individually wrapped in a square of aluminum foil. In order to minimize the amount of wasted material, it is natural to study the problem of wrapping a sphere by an unfolded shape which will tile the plane so as to facilitate cutting the pieces of wrapping material from a large sheet of foil. E. Demaine et al. [75] have considered this problem and shown that the substitution of an equilateral triangle for the square wrapper leads to a savings in material. As shown in Figure 3.31(b), they first cut the surface of the sphere into a number of congruent petals which are then unfolded onto a plane. The resulting shape may then be enclosed by a square (Figure 3.31(c)) or an equilateral triangle (Figure 3.31(d)). Their analysis shows that the latter choice results in a material savings of 0.1%. In addition to the direct savings in material costs, this also indirectly reduces CO_2 emissions, thereby partially alleviating global warming. Way to go Equilateral Triangle!

Application 32 (Triangular Lower and Upper Bounds). *Of all triangles with a given area A , the equilateral triangle has the smallest principal frequency Λ and the largest torsional rigidity P . Thus for any triangle, we have the lower bound $\frac{2\pi}{\sqrt{3}\sqrt{A}} \leq \Lambda$ and the upper bound $P \leq \frac{\sqrt{3}A^2}{15}$ [243].*

The principal frequency Λ is the gravest proper tone of a uniform elastic membrane uniformly stretched and fixed along the boundary of an equilateral triangle of area A . It has been rendered a purely geometric quantity by dropping a factor that depends solely on the physical nature of the membrane. P is the torsional rigidity of the equilateral triangular cross-section, with area A , of a uniform and isotropic elastic cylinder twisted around an axis perpendicular

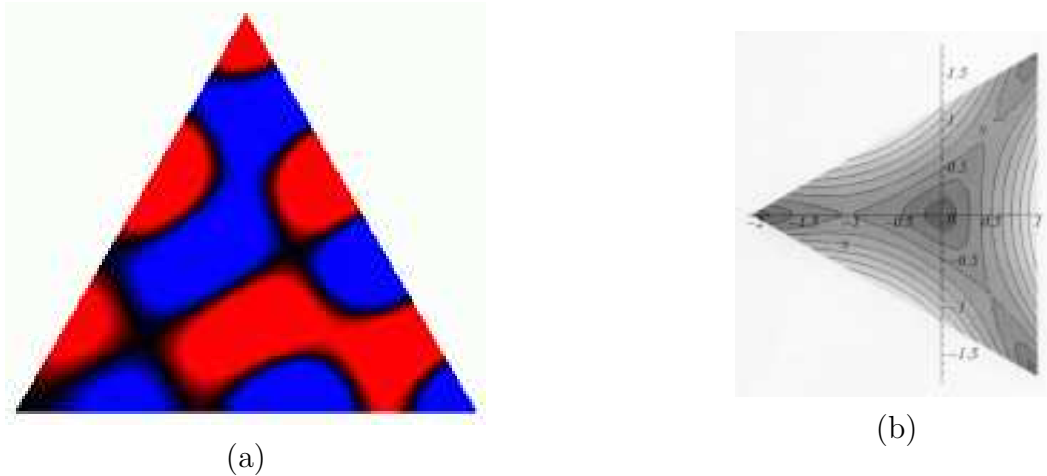

Figure 3.32: Triangular Lower and Upper Bounds: (a) Vibrating Membrane. (b) Cylinder Under Torsion. [243]

to the cross-section. The couple resisting such torsion is equal to $\theta\mu P$ where θ is the twist or angle of rotation per unit length and μ is the shear modulus. So defined, P is a purely geometric quantity depending on the shape and size of the cross-section. Figure 3.32(a) shows one of the vibrational modes of a triangular membrane while Figure 3.32(b) shows the shear stress in the cross-section of an equilateral triangular prism under torsion.

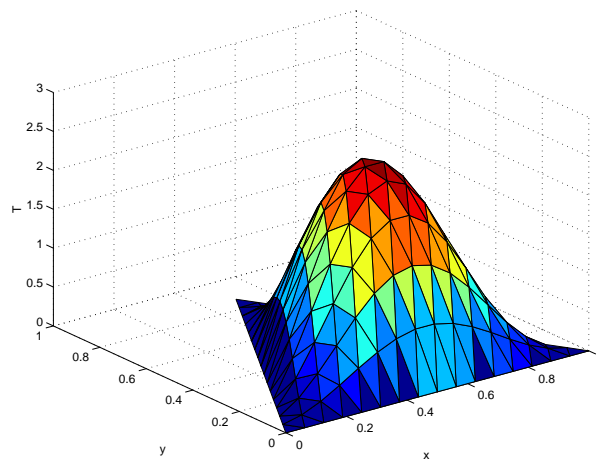

Figure 3.33: Fundamental Mode [219]

Application 33 (Laplacian Eigenstructure). *The eigenvalues and eigenfunctions of the Laplace operator, $\Delta := \frac{\partial^2}{\partial x^2} + \frac{\partial^2}{\partial y^2}$, on the equilateral triangle play an important role in Applied Mathematics.*

The eigenstructure of the Laplacian arises in heat transfer, vibration theory, acoustics, electromagnetics and quantum mechanics to name but a few of its ubiquitous appearances in science and engineering. G. Lamé discovered explicit formulas for the cases of Dirichlet and Neumann boundary conditions which were later extended to the Robin boundary condition by B. J. McCartin [219]. Figure 3.33 shows the fundamental mode for the Dirichlet boundary condition.

Chapter 4

Mathematical Recreations

The impact of the equilateral triangle is considerably extended if we broaden our scope to include the rich field of Recreational Mathematics [273].

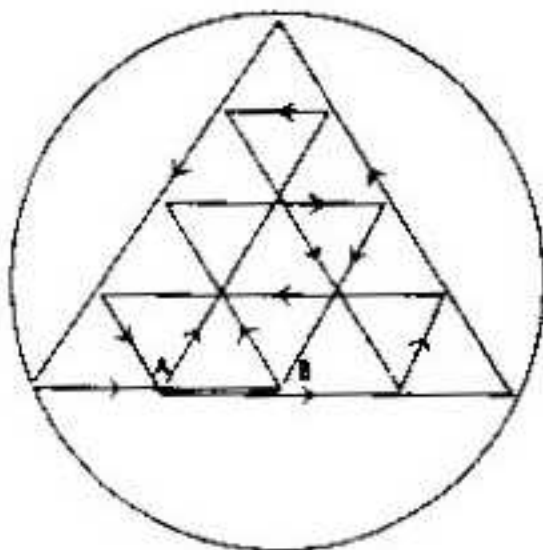

Figure 4.1: Greek Symbol Puzzle [210]

Recreation 1 (Sam Loyd's Greek Symbol Puzzle [210]). *Draw the Greek symbol of Figure 4.1 in one continuous line making the fewest possible number of turns (going over the same line as often as one wishes).*

The displayed solution commences at A and terminates at B with segment \overline{AB} traced twice. It requires only 13 turns (14 strokes). If no segment is traced twice then 14 turns are necessary and sufficient. This same puzzle appeared in [87].

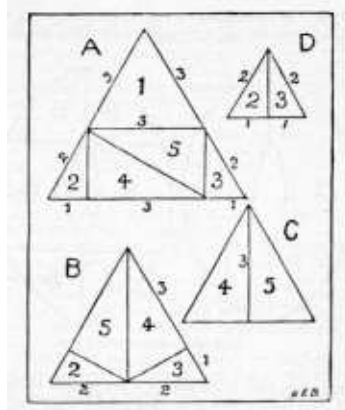

Figure 4.2: Dissected Triangle [86]

Recreation 2 (H. E. Dudeney's Dissected Triangle [86]). *Cut a paper equilateral triangle into five pieces in such a way that they will fit together and form either two or three smaller equilateral triangles, using all the material in each case.*

In Figure 4.2, diagram A is the original triangle, which for the sake of definiteness is assumed to have an edge of 5 units in length, dissected as shown. For the two-triangle solution, we have region 1 together with regions 2, 3, 4 and 5 assembled as in diagram B. For the three-triangle solution, we have region 1 together with regions 4 and 5 assembled as in diagram C and regions 2 and 3 assembled as in diagram D. Observe that in diagrams B and C, piece 5 has been turned over which was not prohibited by the statement of the problem.

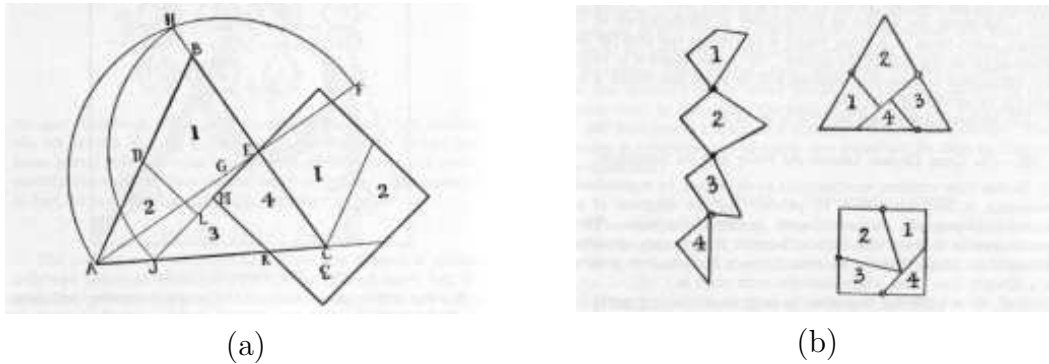

Figure 4.3: (a) Triangle Dissection. (b) Triangle Hinged Dissection. [85]

Recreation 3 (H. E. Dudeney's Haberdasher's Puzzle [85]). *The Haberdasher's Puzzle [85] concerns cutting an equilateral triangular piece of cloth into four pieces that can be rearranged to make a square.*

With reference to Figure 4.3(a): Bisect AB in D and BC in E; produce the line AE to F making EF equal to EB; bisect AF in G and describe arc AHF; produce EB to H, and EH is the length of the side of the required square; from E with distance EH, describe the arc HJ, and make JK equal to BE; now from the points D and K drop perpendiculars on EJ at L and M. The four resulting numbered pieces may be reassembled to form a square as in the Figure. Note that AD, DB, BE, JK are all equal to half the side of the triangle [97]. Also, LJ=ME [66]. As shown in Figure 4.3(b), the four pieces can be hinged in such a way that the resulting chain can be folded into either the square or the original triangle. Dudeney himself displayed such a table made of polished mahogany and brass hinges at the Royal Society in 1905 [85]. An incorrect version of this dissection appeared as Steinhaus' Mathematical Snapshot #2 where the base is divided in the ratio 1:2:1 (the correct ratios are approximately 0.982:2:1.018) [291]. This was corrected as Schoenberg's Mathematical Time Exposure #1 [272] (independently of Dudeney).

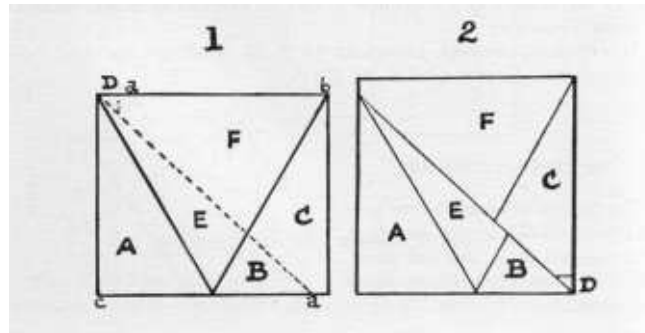

Figure 4.4: Triangle and Square Puzzle [87]

Recreation 4 (H. E. Dudeney's Triangle and Square Puzzle [87]). *It is required to cut each of two equilateral triangles into three pieces so that the six pieces fit together to form a perfect square [87].*

Cut one triangle in half and place the pieces together as in Figure 4.4(1). Now cut along the dotted lines, making ab and cd each equal to the side of the required square. Then, fit together the six pieces as in Figure 4.4(2), sliding the pieces F and C upwards and to the left and bringing down the little piece D from one corner to the other.

Recreation 5 (H. E. Dudeney's Square and Triangle Puzzle [87]). *It is required to fold a perfectly square piece of paper so as to form the largest possible equilateral triangle [87]. (See Property 2.21.)*

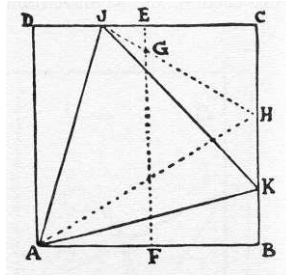

Figure 4.5: Square and Triangle Puzzle [87]

With reference to Figure 4.5, fold the square in half and make the crease FE. Fold the side AB so that the point B lies on FE, and you will get the points F and H from which you can fold HGJ. While B is on G, fold AB back on AH, and you will have the line AK. You can now fold the triangle AJK, which is the largest possible equilateral triangle obtainable.

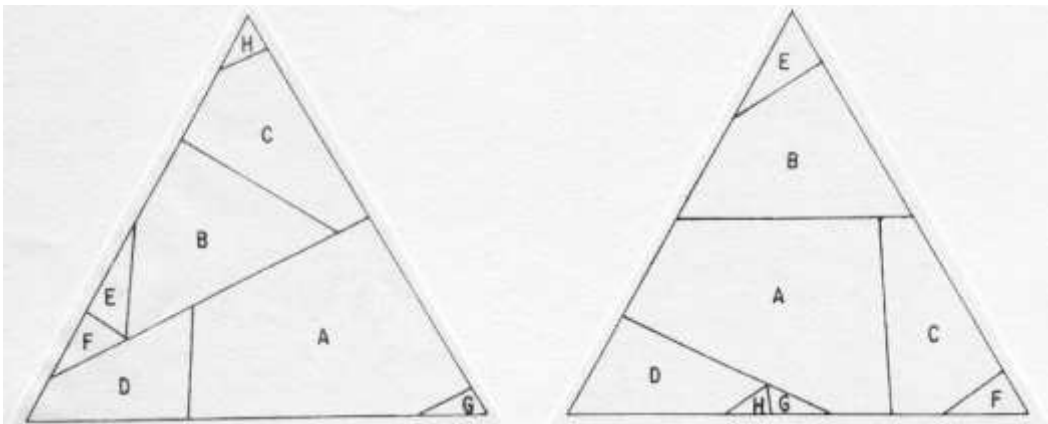

Figure 4.6: Triangle-to-Triangle Dissection [214]

Recreation 6 (Triangle-to-Triangle Dissection [214]). *A given equilateral triangle can be dissected into noncongruent pieces that can be rearranged to produce the original triangle in two different ways.*

Such a dissection of an equilateral triangle into eight pieces is shown in Figure 4.6 [214]. This interesting dissection was found by superimposing two different strips of triangular elements. Incidentally, this is not a minimal-piece dissection.

Recreation 7 (Polygonal Dissections [109]). *Mathematicians' appetite for polygonal dissections never seems to be sated [109].*

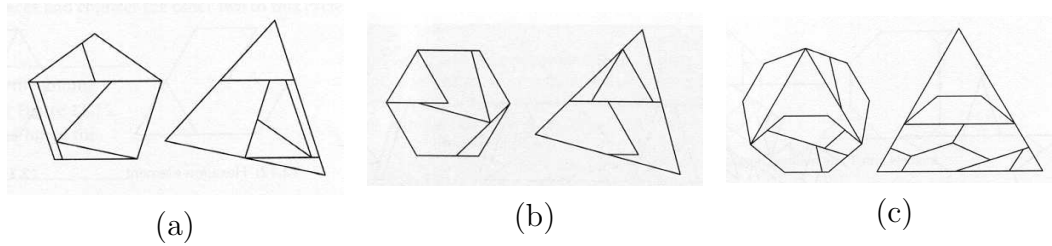

Figure 4.7: Polygon-to-Triangle Dissections; (a) Pentagon. (b) Hexagon. (c) Nonagon (Enneagon). [109]

Witness Figure 4.7: (a) displays Goldberg’s six piece dissection of a regular pentagon; (b) displays Lindgren’s five piece dissection of a regular hexagon; (c) displays Theobald’s eight piece dissection of a regular nonagon (enneagon). All three have been reassembled to form an equilateral triangle and all are believed to be minimal dissections [109].

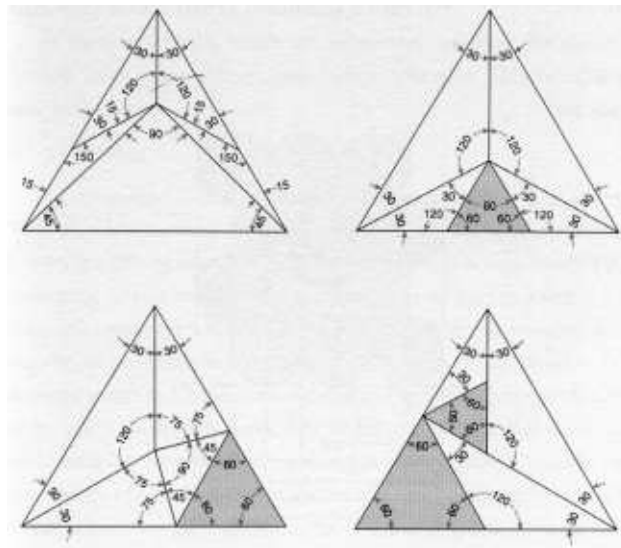

Figure 4.8: Dissections into Five Isosceles Triangles [135]

Recreation 8 (Dissection into Five Isosceles Triangles [135]). *Figure 4.8 shows four ways to cut an equilateral triangle into five isosceles triangles [135].*

The four patterns, devised by R. S. Johnson, include one example of no equilateral triangles among the five, two examples of one equilateral triangle and one example of two equilateral triangles. H. L. Nelson has shown that there cannot be more than two equilateral triangles.

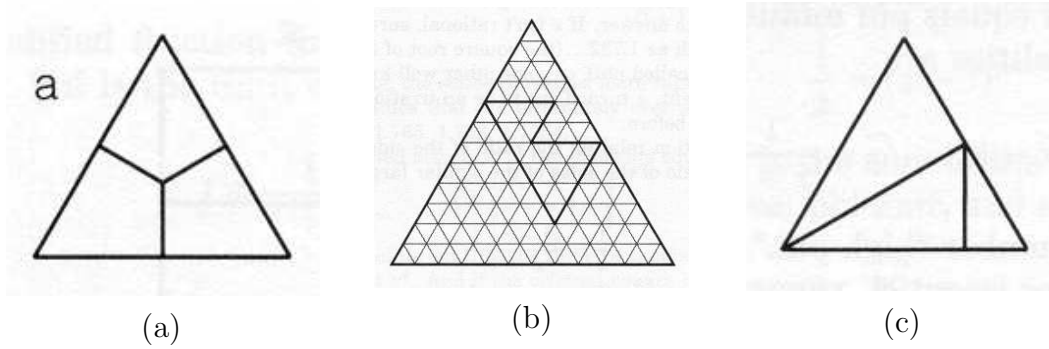

Figure 4.9: Three Similar Pieces: (a) All Congruent. (b) Two Congruent. (c) None Congruent. [138]

Recreation 9 (Dissection into Three Parts [138]). *It is easy to trisect an equilateral triangle into three congruent pieces as in Figure 4.9(a).*

It is much more difficult to dissect it into three similar parts, just two of which are congruent as has been done in Figure 4.9(b). Yet, to dissect the triangle into three similar pieces, none of which are congruent, is again easy (see Figure 4.9(c)) [138].

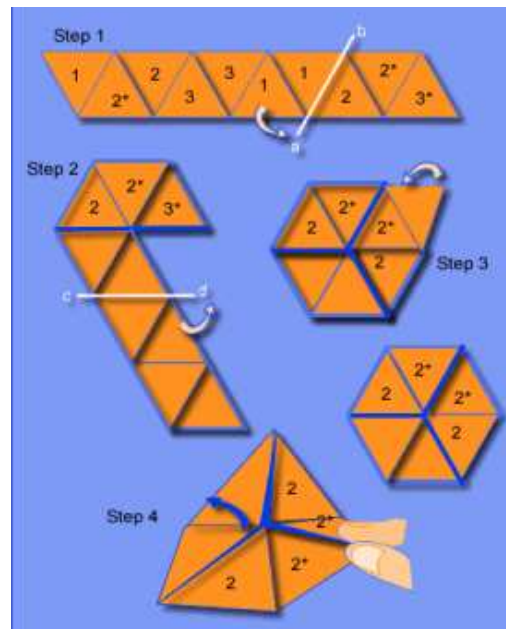

Figure 4.10: Trihexaflexagon [121]

Recreation 10 (Trihexaflexagon [121]). *Flexagons are paper polygons which have a surprising number of faces when “flexed” [121].*

To form a trihexaflexagon, begin with a strip of paper with ten equilateral triangles numbered as shown in Figure 4.10. Then, fold along ab , fold along cd , fold back the protruding triangle and glue it to the back of the adjacent triangle and Voila! The assembled trihexaflexagon is a continuous band of hinged triangles with a hexagonal outline (“face”). If the trihexaflexagon is “pinch-flexed” [244], as shown, then one face will become hidden and a new face appears. This remarkable geometrical construction was discovered by Arthur H. Stone when he was a Mathematics graduate student at Princeton University in 1939. A Flexagon Committee consisting of Stone, Bryant Tuckerman, Richard P. Feynman and John W. Tukey was formed to probe its mathematical properties which are many and sundry [244].

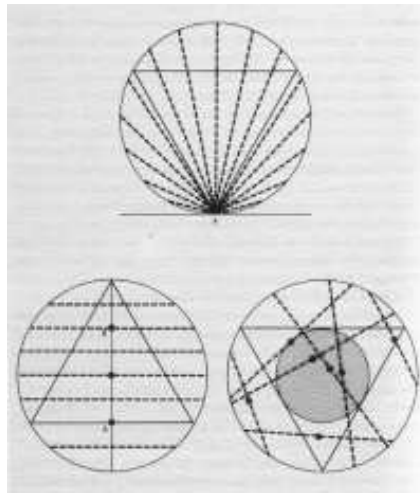

Figure 4.11: Bertrand’s Paradox [122]

Recreation 11 (Bertrand’s Paradox [122]). *The probability that a chord drawn at random inside a circle will be longer than the side of the inscribed equilateral triangle is equal to $\frac{1}{3}$, $\frac{1}{2}$ and $\frac{1}{4}$ [122]!*

With reference to the top of Figure 4.11, if one endpoint of the chord is fixed at A and the other endpoint is allowed to vary then the probability is equal to $\frac{1}{3}$. Alternatively (Figure 4.11 bottom left), if the diameter perpendicular to the chord is fixed and the chord allowed to slide along it then the probability is equal to $\frac{1}{2}$. Finally (Figure 4.11 bottom right), if both endpoints of the chord are free and we focus on its midpoint then the required probability is computed to be $\frac{1}{4}$. Physical realizations of all three scenarios are provided in [122] thus showing that caution must be used when the phrase “at random” is bandied about, especially in a geometric context.

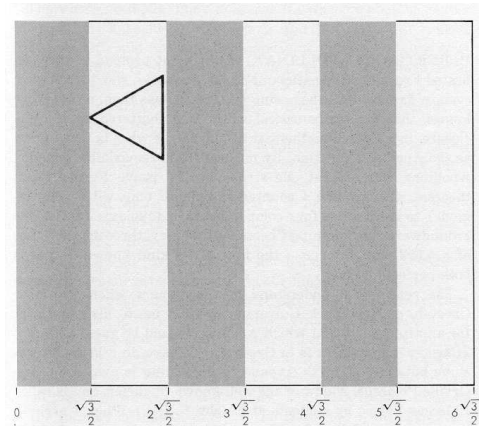

Figure 4.12: Two-Color Map [123]

Recreation 12 (Two-Color Map [123]). *How can a two-color planar map be drawn so that no matter how an equilateral triangle with unit side is placed on it, all three vertices never lie on points of the same color [123]?*

A simple solution is shown in Figure 4.12 where the vertical stripes are closed on the left and open on the right [123]. It is an open problem as to how many colors are required so that no *two* points, a unit distance apart, lie on the same color. However, it is known that four colors are necessary and seven colors are sufficient.

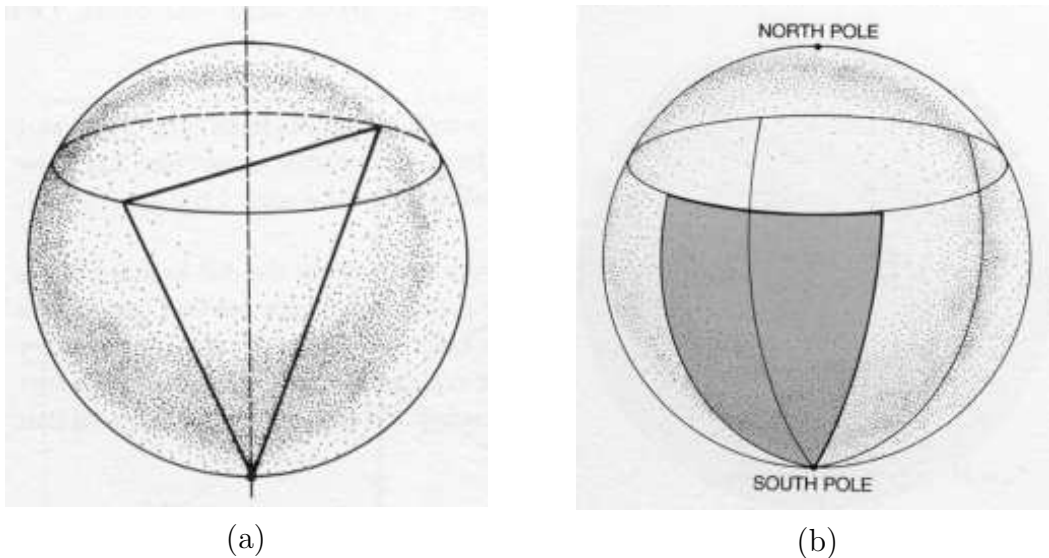

Figure 4.13: Sphere Coloring: (a) The Problem. (b) Five Colors Are Sufficient. [131]

Recreation 13 (Erdős' Sphere Coloring Problem [131]). *Paul Erdős proposed the following unsolved problem in graph theory. What is the minimum number of colors required to paint all of the points on the surface of a unit sphere so that, no matter how we inscribe an equilateral triangle of side $\sqrt{3}$ (the largest such triangle that can be so inscribed), the triangle will have each corner on a different color (Figure 4.13(a)) [131]?*

E. G. Straus has shown that five colors suffice. In his five-coloring (shown in Figure 4.13(b)), the north polar region is open with boundary circle of diameter $\sqrt{3}$. The rest of the sphere is divided into four identical regions, each closed along its northern and eastern borders, as indicated by the heavy black line on the dark shaded region. One color is given to the cap and to the south pole. The remaining four colors are assigned to four quadrant regions. G. J. Simmons has shown that three colors are not sufficient so that at least four colors are necessary. It is unknown whether four or five colors are both necessary and sufficient. The analogous problem for the plane, i.e. the minimum number of colors which ensures that every equilateral triangle of unit side will have its corners on different colors, is also open. Indeed, it is equivalent to asking for a minimal coloring of the plane so that every unit line segment has its endpoints on different colors, a problem which was discussed at the end of the previous Recreation. This problem may be recast in terms of the chromatic number of planar graphs [131].

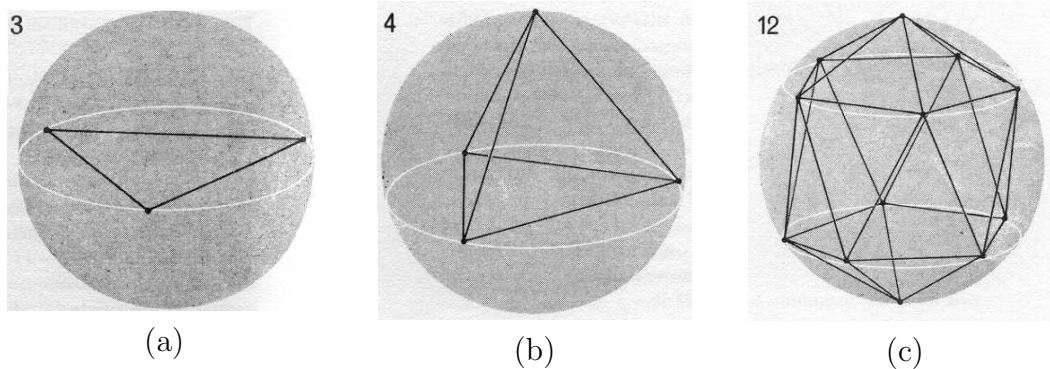

Figure 4.14: Optimal Spacing of Lunar Bases: (a) $n=3$. (b) $n=4$. (c) $n=12$. [124]

Recreation 14 (Optimal Spacing of Lunar Bases [124]). *Assume that the moon is a perfect sphere and that we want to establish n lunar bases as far apart from one another as possible.*

I.e., how can n points be arranged on a sphere so that the smallest distance between any pair of points is maximized? This problem is equivalent to that

of placing n equal, nonoverlapping circles on a sphere so that the radius of each circle is maximized [124]. The solution for the cases $n = 3, 4, 12$ appear in Figure 4.14 and all involve equilateral triangles. The solution for cases $2 \leq n \leq 12$ and $n = 24$ are known, otherwise the solution is unknown [124].

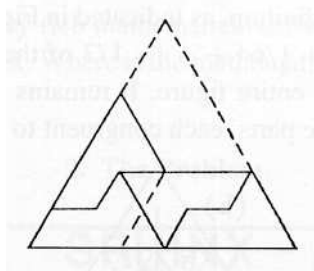

Figure 4.15: Rep-4 Pentagon: The Sphinx [146]

Recreation 15 (Replicating Figures: Rep-tiles [125]). *In 1964, S. W. Golomb gave the name “rep-tile” to a replicating figure that can be used to assemble a larger copy of itself or, alternatively, that can be dissected into smaller replicas of itself [146]. If four copies are required then this is abbreviated rep-4.*

Figure 4.15 contains a rep-4 pentagon, known as the Sphinx, which may be regarded as composed of six equilateral triangles or two-thirds of an equilateral triangle [146]. The Sphinx is the only known 5-sided rep-tile [296, p. 134]. Figure 4.16 contains three examples of rep-4 nonpolygonal figures composed of equilateral triangles: the Snail, the Lamp and the Carpenter’s Plane [125]. Each of these figures, shown at the left, is formed by adding to an equilateral triangle an endless sequence of smaller triangles, each one one-fourth the size of its predecessor. In each case, four of these figures will fit together to make a larger replica, as shown on the right. (There is a gap in each replica because the original figure cannot be drawn with an infinitely long sequence of triangles.)

Recreation 16 (Hexiamonds [126]). *Hexiamonds were invented by S. W. Golomb in 1954 and officially named by T. H. O’Beirne in 1961. Each hexiamond is composed of six equilateral triangles joined along their edges. Treating mirror images as identical, there are exactly 12 of them (Figure 4.17) [126].*

Much is known about the mathematical properties of hexiamonds. For example, the six-pointed star of Figure 4.18(a) is known to have the unique eight-piece solution of Figure 4.18(b) [126]. Sets of plastic hexiamonds were marketed in the late 1960’s, under various trade names, in England, Japan, and West Germany.

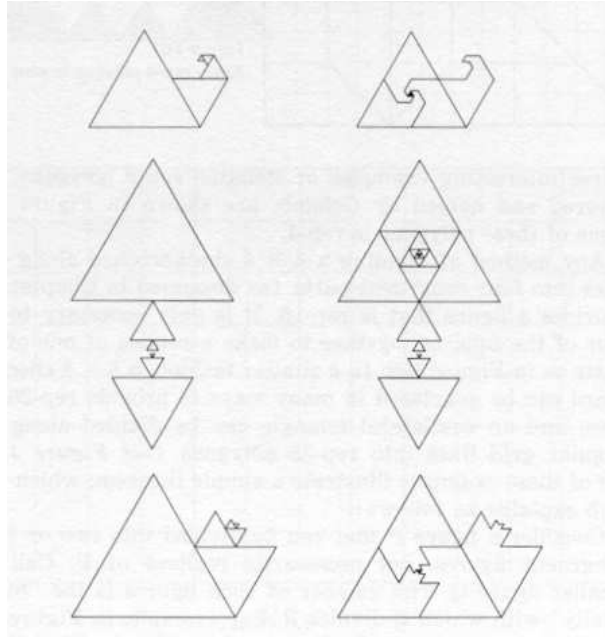

Figure 4.16: Rep-4 Non-Polygons: The Snail, The Lamp, and The Carpenter's Plane [125]

Recreation 17 (MacMahon's 24 Color Triangles [128]). *In 1921, Major Percy A. MacMahon, a noted combinatorialist, introduced a set of 24 color triangles [213], the edges of which are colored with one of four colors, that are pictured in Figure 4.19 [128]. (Rotations of triangles are not considered different but mirror-image pairs are considered distinct.) The pieces are to be fitted together with adjacent edges matching in color to form symmetrical polygons, the border of which must all be of the same color.*

It is known that all polygons so assembled from the 24 color triangles must have perimeters of 12, 14, or 16 unit edges. Also, only one polygon, the regular hexagon, has the minimum perimeter of 12. Its one-color border can be formed in six different ways, each with an unknown number of solutions. For each type of border, the hexagon can be solved with the three triangles of solid color (necessarily differing in color from the border) placed symmetrically around the center of the hexagon. Since each solid-color triangle must be surrounded by triangular segments of the same color, the result is three smaller regular hexagons of solid color situated symmetrically at the center of the larger hexagon. Figure 4.20 displays a hexagon solution for each of the six possible border patterns [128]. As previously noted, it is not known how many solutions there are of these six types although the total number of solutions has been estimated to be in the thousands.

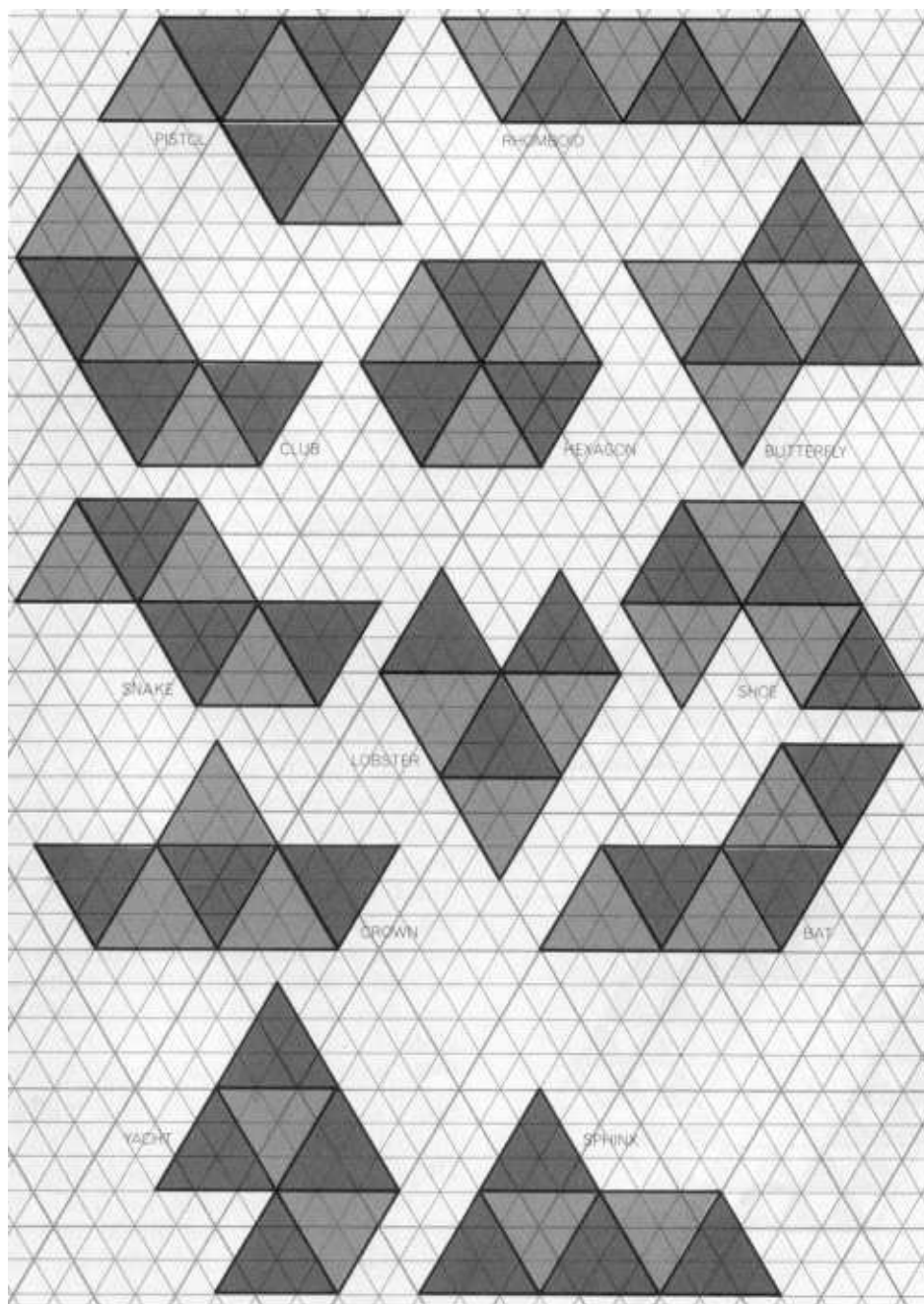
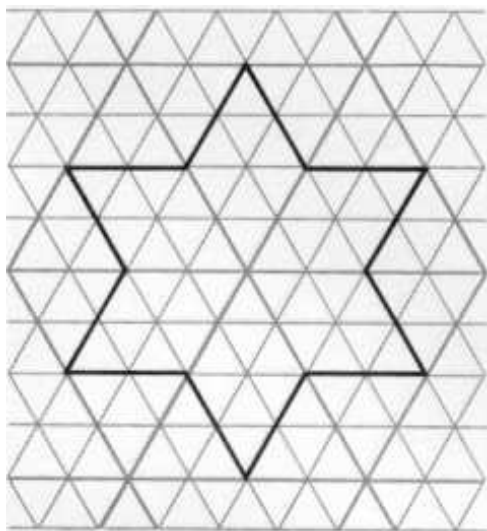
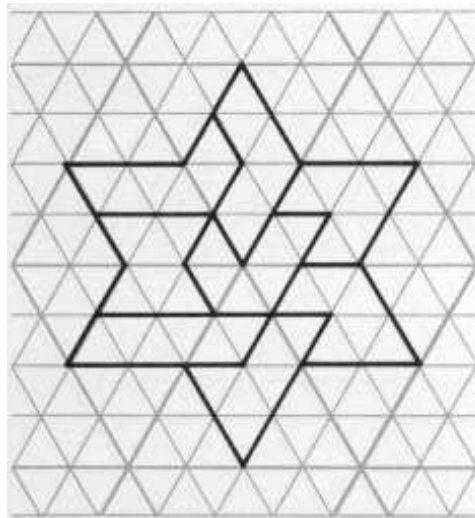

Figure 4.17: The 12 Hexiamonds [126]



(a)



(b)

Figure 4.18: Hexiamond Star: (a) Problem. (b) Solution. [126]

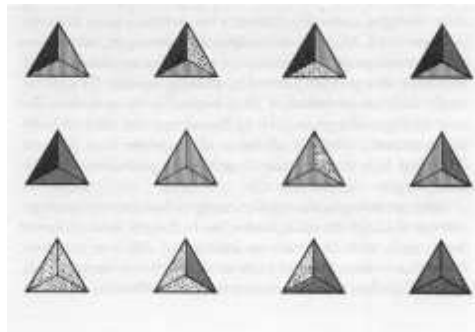
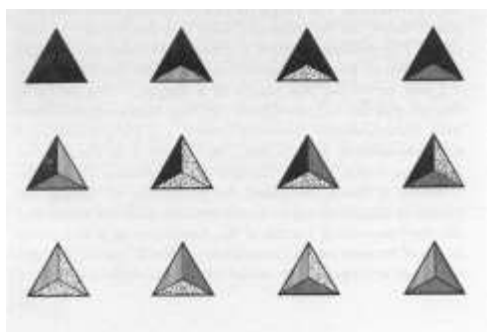

Figure 4.19: MacMahon's 24 Color Triangles [128]

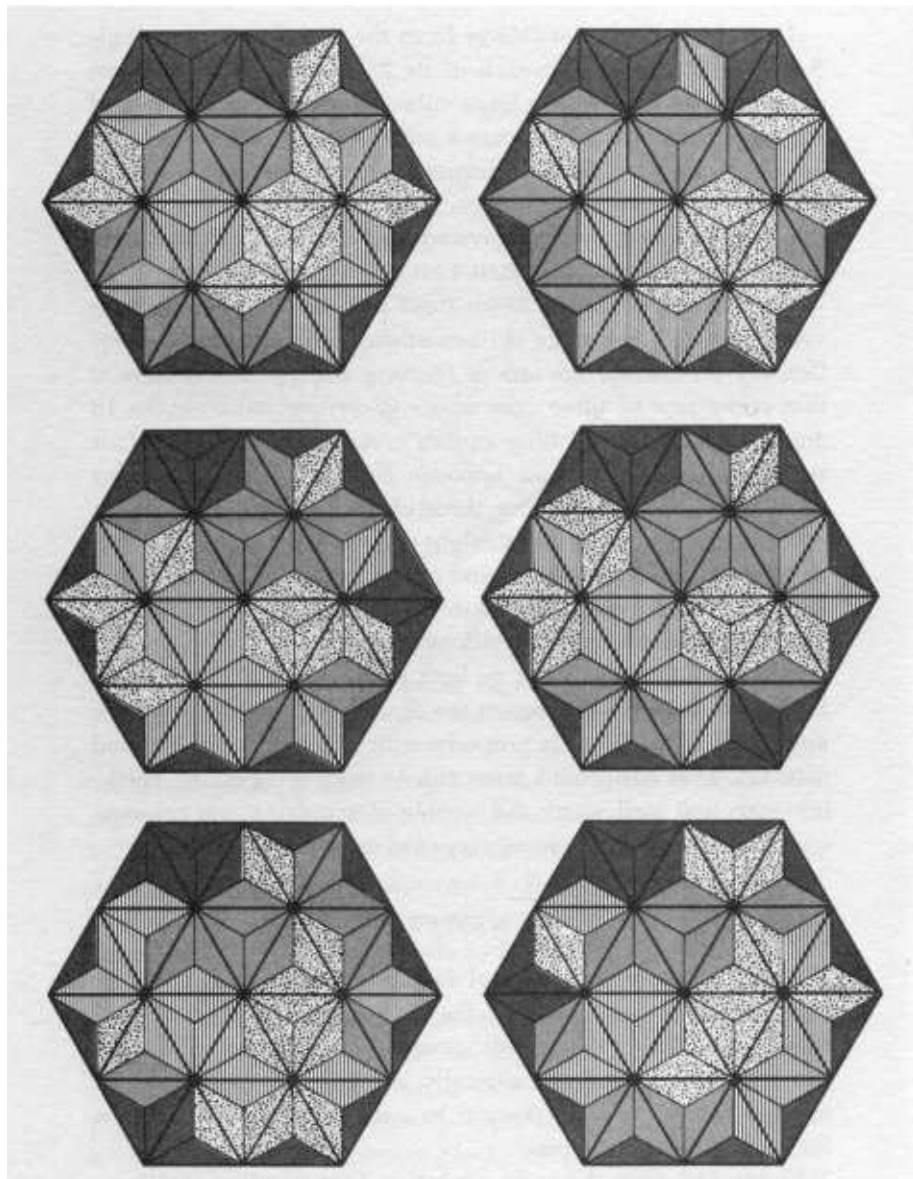

Figure 4.20: Six Solutions to the Hexagon Problem [128]

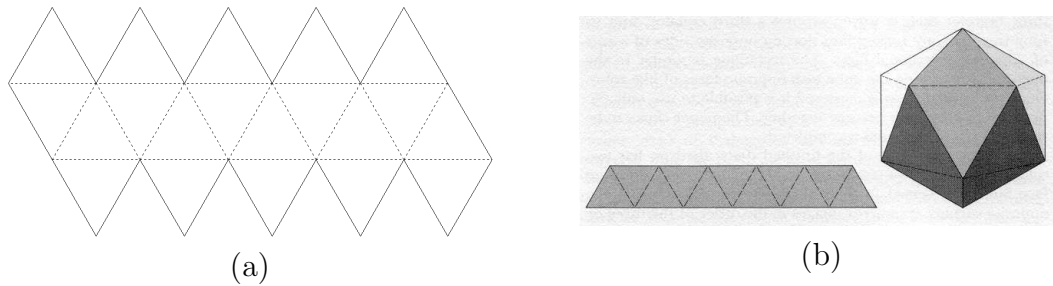

Figure 4.21: Icosahedron: (a) Icosahedron Net. (b) Five-Banded Icosahedron. [130]

Recreation 18 (Plaited Polyhedra [130]). *Traditionally [66], paper models of the five Platonic solids are constructed from “nets” like that shown in Figure 4.21(a) for the icosahedron. The net is cut out along the solid line, folded along the dotted lines, and the adjacent faces are then taped together. In 1973, Jean J. Pedersen of Santa Clara University discovered a method of weaving or braiding (“plaiting”) the Platonic solids from n congruent straight strips. Each strip is of a different color and each model has the properties that every edge is crossed at least once by a strip, i.e. no edge is an open slot, and every color has an equal area exposed on the model’s surface. (An equal number of faces will be the same color on all Platonic solids except the dodecahedron, which has bicolored faces when braided by this technique.) She has proved that if these two properties are satisfied then the number of necessary and sufficient bands for the tetrahedron, cube, octahedron, icosahedron and dodecahedron are two, three, four, five and six, respectively [130].*

With reference to Figure 4.21(b), the icosahedron is woven with five valley-creased strips. A visually appealing model can be constructed with each color on two pairs of adjacent faces, the pairs diametrically opposite each other. All five colors go in one direction around one corner and in the opposite direction, in the same order, around the diametrically opposite corner. Each band circles an “equator” of the icosahedron, its two end triangles closing the band by overlapping. In making the model, when the five overlapping pairs of ends surround a corner, all except the last pair can be held with paper clips, which are later removed. The last overlapping end then slides into the proper slot. Experts may dispense with the paper clips [130]. Previous techniques of polyhedral plaiting involved nets of serpentine shape [322].

Recreation 19 (Pool-Ball Triangles [133]). *Colonel George Sicherman of Buffalo asked while watching a game of pool: Is it possible to form a “difference triangle” in arranging the fifteen balls in the usual equilateral triangular configuration at the beginning of a game?*

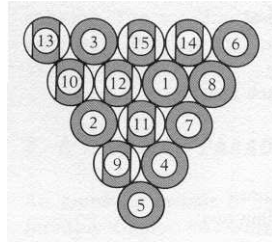

Figure 4.22: Pool-Ball Triangle [133]

In a difference triangle, the consecutive numbers are arranged so that each number below a pair of numbers is the positive difference between that pair. He easily found two solutions for three balls and four solutions each for six and ten balls. However, he was surprised to discover that, for all fifteen balls, there is only the single solution shown in Figure 4.22, up to reflection. Incidentally, it has been proved that no difference triangle can have six or more rows [295, p. 7].

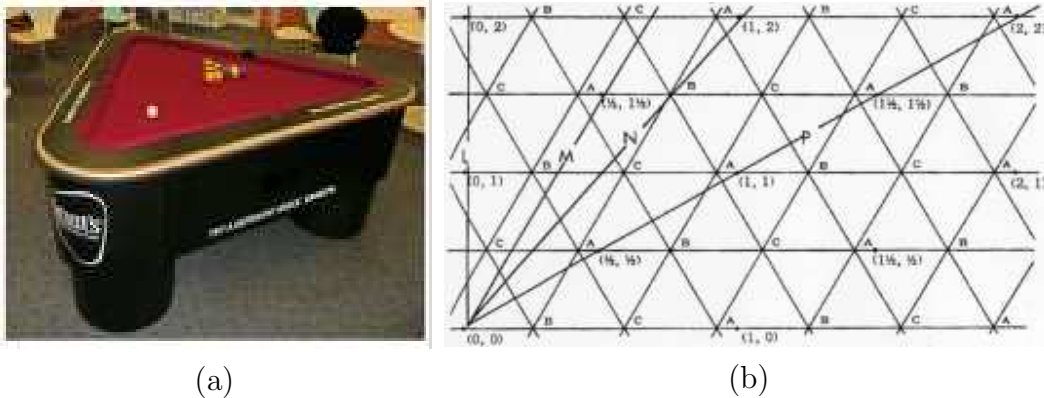

Figure 4.23: Equilateral Triangular Billiards: (a) Triangular Pool Table. (b) Unfolding Billiard Orbits. [198]

Recreation 20 (Equilateral Triangular Billiards [198]). In the “billiard ball problem”, one seeks periodic motions of a billiard ball on a convex billiard table, where the law of reflection at the boundary is that the angle of incidence equals the angle of reflection [24, pp. 169-179]. Even for triangular pool tables, the present state of our knowledge is very incomplete. For example, it is not known if every obtuse triangle possesses a periodic orbit and, for a general non-equilateral acute triangle, the only known periodic orbit is the Fagnano orbit consisting of the pedal triangle (see Figure 2.35 right) [158]. However, the equilateral triangular billiard table possesses infinitely many periodic orbits [16].

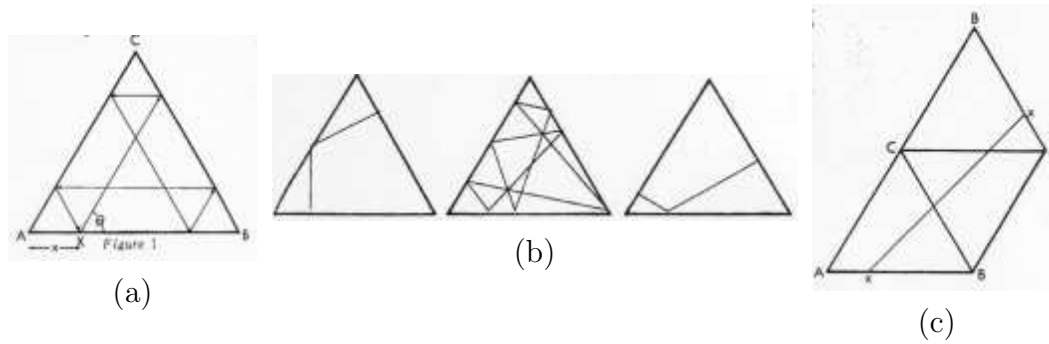

Figure 4.24: Triangular Billiards Redux: (a) Notation. (b) Some Orbits. (c) Gardner’s Gaffe. [198]

In his September 1963 “Mathematical Games” column in *Scientific American* [118], Martin Gardner put forth a flawed analysis of periodic orbits on an equilateral triangular billiards table. In 1964, this motivated D. E. Knuth to provide a correct, simple and comprehensive analysis of periodic billiard orbits on an equilateral triangular table (see Figure 4.23(a)) [198]. His analysis involves “unfolding” periodic orbits using the Schwarz reflection procedure previously alluded to in our prior treatment of Fagnano’s problem of the shortest inscribed triangle in Chapter 2 (Property 53). This results in the tiling of the plane by repeated reflections of the billiard table ABC shown in Figure 4.23(b). Straight lines superimposed on this figure, such as L, M, N, P , give paths in the original triangle satisfying the reflection law if the diagram is folded appropriately. Conversely, any infinite path satisfying the reflection law corresponds to a straight line in this diagram.

Turning our attention to Figure 4.24(a) where AB has unit length, $0 < x < 1$ is the point from which the billiard ball is launched at an angle θ and we wish to determine those launching angles which result in endlessly repeating periodic trajectories. The particular trajectory shown there corresponds to the important special case $\theta = 60^\circ$ and is associated with path M of Figure 4.23(b). If $x = 1/3$ then this would coincide with the closed light path of Figure 2.35. If $x = 1/2$ then this becomes the Fagnano orbit and we (usually) exclude this highly specialized orbit from further consideration in what follows. Two other special cases deserve attention: $\theta = 90^\circ$ (Figure 4.24(b)left and path L in Figure 4.23(b)) and $\theta = 30^\circ$ (Figure 4.24(b) right and path P in Figure 4.23(b)), which are unusual in that one half of the path retraces the other half in the opposite direction. A generic periodic orbit is shown in Figure 4.24(b) center which corresponds to path N in Figure 4.23(b).

Now that the Fagnano orbit has been effectively excluded, Knuth shows that periodic orbits correspond to lines in Figure 4.23(b) connecting the original x to one of its images on a horizontal line and these are labeled with coordinates (i, j) of two types, either (m, n) or $(m + 1/2, n + 1/2)$, where m

and n are integers. He then states and proves his main results:

Theorem 4.1. *A path is cyclic if and only if $\theta = 90^\circ$, or if $\tan \theta = r/\sqrt{3}$, where r is a nonzero rational number. Moreover,*

- *The length of the path traveled in each cycle may be determined as follows: Let $\tan \theta = p/(q\sqrt{3})$ where p and q are integers with no common factor, and where $p > 0$, $q \geq 0$. Then the length is $k\sqrt{3p^2 + 9q^2}$ where $k = 1/2$ if p and q are both odd, $k = 1$ otherwise; except when $\theta = 60^\circ$ and $x = 1/2$ (Fagnano orbit), when the length is $3/2$.*
- *If $x \neq 1/2$, the shortest path length is $\sqrt{3}$ and it occurs when $\theta = 30^\circ$ and $\theta = 90^\circ$.*
- *The number of bounces occurring in each cycle may be determined as follows (when the path leads into a corner, this is counted as three bounces, as can be justified by a limiting argument): With p, q, k as above, the number of bounces is $k[2p + \min(2p, 6q)]$; except when $\theta = 60^\circ$ and $x = 1/2$ (Fagnano orbit), when the number of bounces is 3.*
- *If $x \neq 1/2$, the least number of bounces per cycle is 4 and it occurs when $\theta = 30^\circ$ and $\theta = 90^\circ$. With the exception of the Fagnano orbit, the number of bounces is always even.*

Finally, Knuth takes up Gardner's gaffe where he claimed that the path obtained by folding Figure 4.24(c) yields a periodic orbit. However, unless $\theta = 60^\circ$ and $x = 1/2$, the angle of incidence is not equal to the angle of reflection at x . Knuth then shows that the extended path is cyclical if and only if x is rational. Baxter and Umble [16], evidently unaware of Knuth's earlier pathbreaking work on equilateral triangular billiards, provide an analysis of this problem *ab initio*. However, they introduce an equivalence relation on the set of all periodic orbits where equivalent periodic orbits share the same number of bounces, path length and incidence angles (up to permutation). They also count the number of equivalence classes of orbits with a specified (even) number of bounces.

Recreation 21 (Tartaglian Measuring Puzzles [62]). *The following liquid-pouring puzzle is due to the Renaissance Mathematician Niccolò Fontana, a.k.a. Tartaglia ("The Stammerer") [118]. An eight-pint vessel is filled with water. By means of two empty vessels that hold five and three pints respectively, divide the eight pints evenly between the two larger vessels by pouring water from one vessel into another. In any valid solution, you are not allowed to estimate quantities, so that you can only stop pouring when one of the vessels becomes either full or empty. In 1939, M. C. K. Tweedie [311] showed how to solve this and more general pouring problems by utilizing the trajectory of a bouncing ball upon an equilateral triangular lattice (Figure 4.25).*

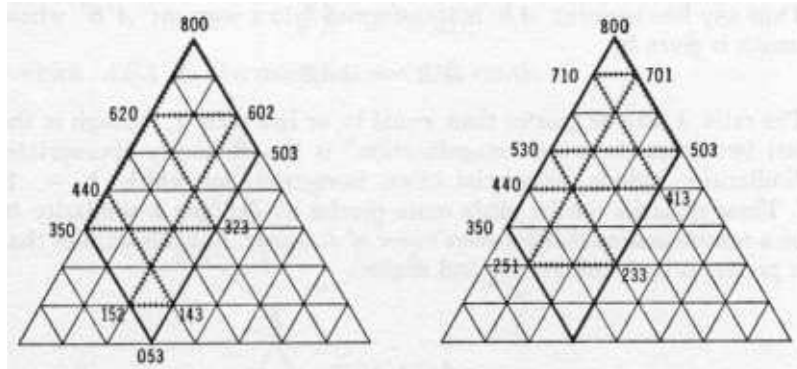

Figure 4.25: Tartaglian Measuring Puzzle [62]

In the ternary diagrams of Figure 4.25, the horizontal lines correspond to the contents of the the 8-pint vessel while the downward/upward slanting lines correspond to that of the 5/3-pint vessel, respectively. The closed highlighted parallelogram corresponds to the possible states of the vessels with those on the boundary corresponding to the states with one or more of the vessels either completely full or completely empty, i.e. the valid intermediate states in any proposed solution. The number triplets indicate how much each vessel holds at any stage of the solution process in the order (8-pint, 5-pint, 3-pint).

Starting at the apex marked by the initial state 800, the first move must be to fill either the 5-pint vessel (Figure 4.25 left) or the 3-pint vessel (Figure 4.25 right). Thereafter, we follow the path of a billiard ball bouncing on the indicated parallelogram until finally reaching the final state 440. The law of reflection is justified by the fact that each piece of the broken lines, shown hashed in Figure 4.25, are parallel to a side of the outer triangle of reference and so represent the act of pouring liquid from one vessel into another while the third remains untouched. Figure 4.25 left thereby yields the seven-step solution:

$$800 \rightarrow 350 \rightarrow 323 \rightarrow 620 \rightarrow 602 \rightarrow 152 \rightarrow 143 \rightarrow 440,$$

while Figure 4.25 right generates the eight-step solution:

$$800 \rightarrow 503 \rightarrow 530 \rightarrow 233 \rightarrow 251 \rightarrow 701 \rightarrow 710 \rightarrow 413 \rightarrow 440.$$

A more detailed study of this technique, especially as to its generalizations and limitations, is available in the literature [118, 229, 296]

Recreation 22 (Barrel Sharing [284]). *Barrel sharing problems have been common recreational problems since at least the Middle Ages [284]. In their simplest manifestation, N full, N half-full and N empty barrels are to be shared*

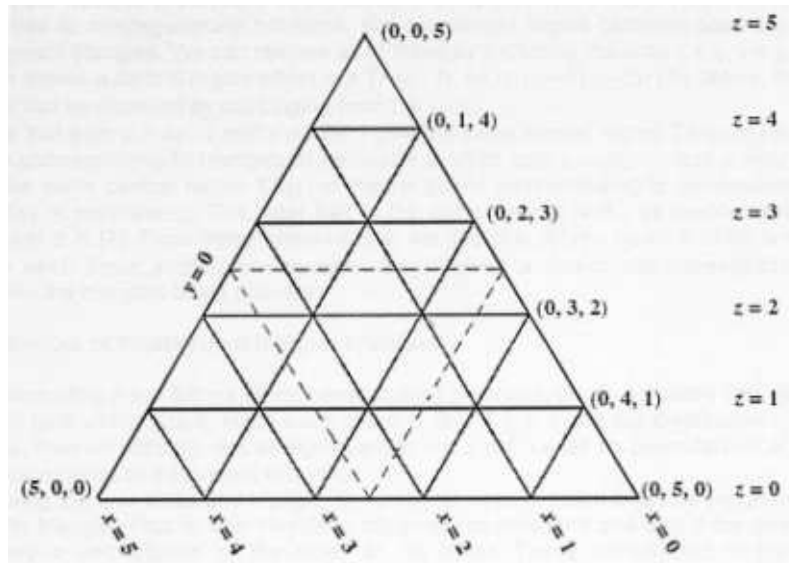
Figure 4.26: Barrel Sharing ($N = 5$) [284]

among three persons so that each receives the same amount of contents and the same number of barrels. Using equilateral triangular coordinates, D. Singmaster [284] has shown that the solutions of this problem correspond to triangles with integer sides and perimeter N .

Suppose that there are N barrels of each type (full, half-full and empty) and let f_i, h_i, e_i be the nonnegative integer number of these that the i th person receives ($i = 1, 2, 3$). Then, a fair sharing is defined as one satisfying the following conditions:

$$f_i + h_i + e_i = N, \quad f_i + \frac{h_i}{2} + \frac{N}{2} \quad (i = 1, 2, 3); \quad \sum_{i=1}^3 f_i = \sum_{i=1}^3 h_i = \sum_{i=1}^3 e_i = N.$$

In turn, these conditions lead to the equivalent conditions:

$$e_i = f_i, \quad h_i = N - 2f_i, \quad f_i \leq \frac{N}{2} \quad (i = 1, 2, 3); \quad \sum_{i=1}^3 f_i = N.$$

However, three nonnegative lengths x, y, z can form a triangle if and only if the three triangle inequalities hold:

$$x + y \geq z, \quad y + z \geq x, \quad z + x \geq y.$$

Setting $x + y + z = p$, this is equivalent to

$$x \leq \frac{p}{2}, \quad y \leq \frac{p}{2}, \quad z \leq \frac{p}{2}.$$

Hence, the solutions for sharing N barrels of each type are just the integral lengths that form a triangle of perimeter N . Consider a triangle of sides x, y, z and perimeter p . Since $x + y + z = p$, we can establish the ternary diagram of Figure 4.26 ($N = 5$) where the dashed central region corresponds to the inequalities: $x \leq p/2, y \leq p/2, z \leq p/2$. The three (equivalent) solutions contained in this region correspond to two persons receiving 2 full, 1 half-full and 2 empty barrels, and one person receiving 1 full, 3 half-full and 1 empty barrel. Singmaster [284] includes in his analysis a counting procedure for the number of non-equivalent solutions and considers more general barrel sharing problems.

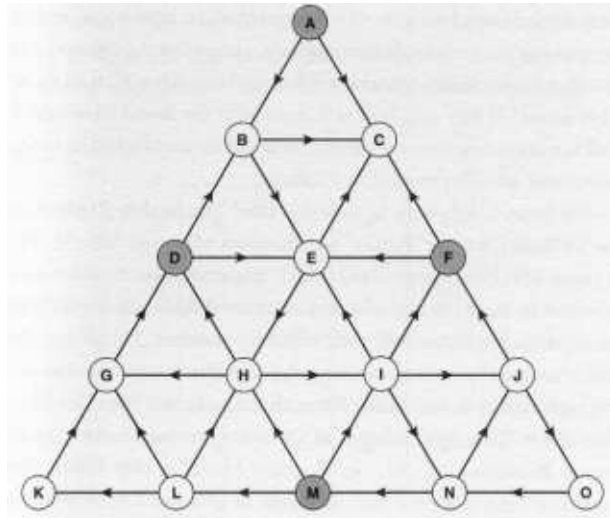

Figure 4.27: Fraenkel’s “Traffic Jam” Game [135]

Recreation 23 (“Traffic Jam” Game [135]). *A. S. Fraenkel, a mathematician at the Weizmann Institute of Science in Israel, invented the game “Traffic Jam” which is played on the directed graph shown in Figure 4.27 [135].*

A coin is placed on each of the four shaded spots A, D, F and M . Players take turns moving any one of the coins along one of the directed edges of the graph to an adjacent spot whether or not that spot is occupied. (Each spot can hold any number of coins.) Note that A is a source (all arrows point outwards) and C is a sink (all arrows point inwards). When all four coins are on sink C , the person whose turn it is to move has nowhere to move and so loses the game. J. H. Conway has proved that the first player can always win if and only if his first move is to from M to L . Otherwise, his opponent can force a win or a draw, assuming that both players always make their best moves.

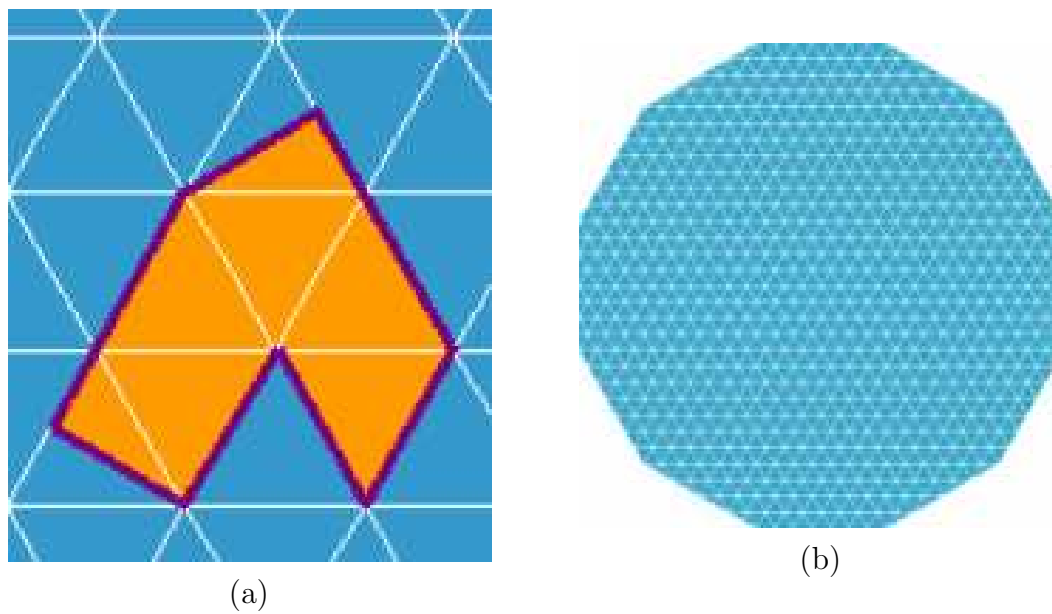

Figure 4.28: Eternity Puzzle: (a) Sample Piece. (b) Puzzle Board. [313]

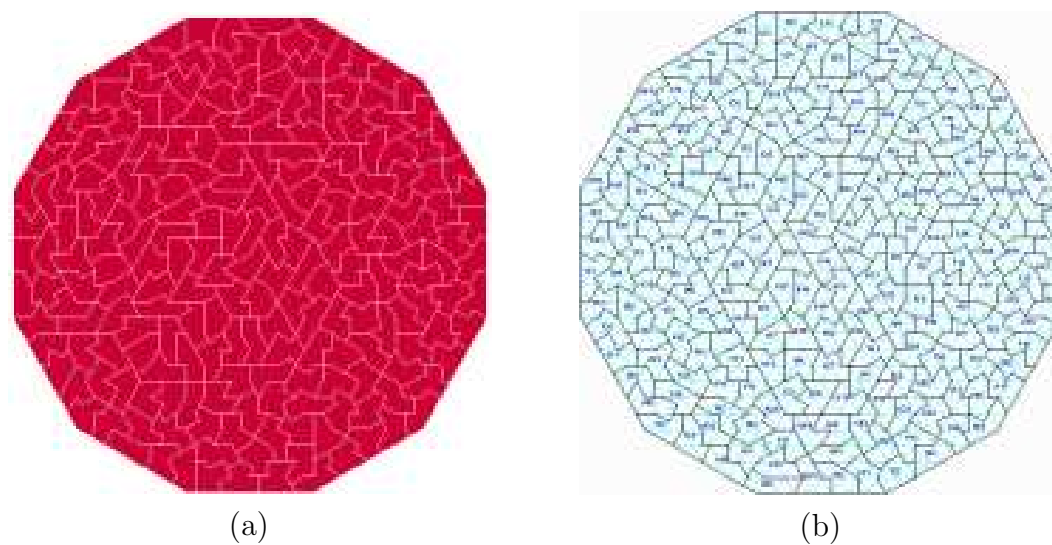

Figure 4.29: Eternity Puzzle Solutions: (a) Selby-Riordan. (b) Stertenbrink. [238]

Recreation 24 (Eternity Puzzle [242]). *The Eternity Puzzle [242] is a jigsaw puzzle comprised of 209 pieces constructed from 12 hemi-equilateral ($30^\circ - 60^\circ - 90^\circ$) triangles (Figure 4.28(a)). These pieces must be assembled into an almost-regular dodecagon on a game board with a triangular grid (Figure 4.28(b)).*

In June 1999, the inventor of the puzzle, Christopher Monckton, offered a £1M prize for its solution. In May 2000, two mathematicians, Alex Selby and Oliver Riordan, claimed the prize with their solution shown in Figure 4.29(a). In July 2000, Günter Stertenbrink presented the independent solution shown in Figure 4.29(b). As these two solutions do not conform to the six clues provided by Monckton, his solution, which remains unknown, is presumably different. This is not surprising since it is estimated that the Eternity Puzzle has on the order of 10^{95} solutions (it is estimated that there are approximately 8×10^{80} atoms in the observable universe), but these are the only two (three?) that have been found!

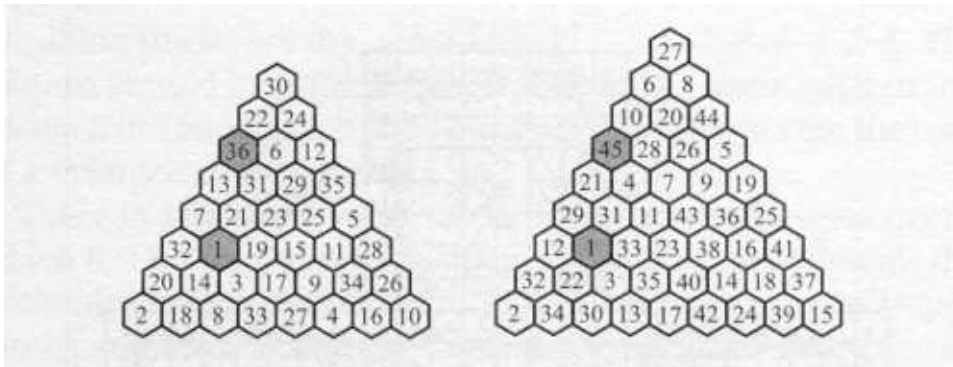

Figure 4.30: Knight's Tours on a Triangular Honeycomb [316]

Recreation 25 (Knight's Tours on a Triangular Honeycomb [316]). *The traditional 8×8 square chessboard may be replaced by using hexagons rather than squares and build chessboards, called triangular honeycombs by their inventor Heiko Harborth of the Technical University of Braunschweig, in the shape of equilateral triangles. Knight's Tours for boards of orders 8 and 9 are on display in Figure 4.30 [316].*

The subject of Knight's Tours on the traditional chessboard have a rich mathematical history [242]. The earliest recorded solution was provided by de Moivre which was subsequently "improved" by Legendre. Euler was the first to write a mathematical paper analyzing Knight's Tours.

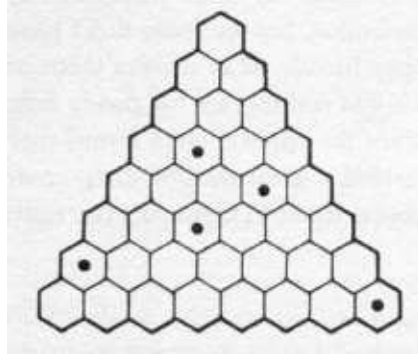

Figure 4.31: Nonattacking Rooks on a Triangular Honeycomb [136]

Recreation 26 (Nonattacking Rooks on a Triangular Honeycomb [136]). *The maximum number of nonattacking rooks that can be placed on a triangular honeycomb of order n is known for $1 \leq n \leq 13$: 1, 1, 2, 3, 3, 4, 5, 5, 6, 7, 7, 8, 9. Figure 4.31 shows such a configuration of 5 rooks on an order-8 board [136].*

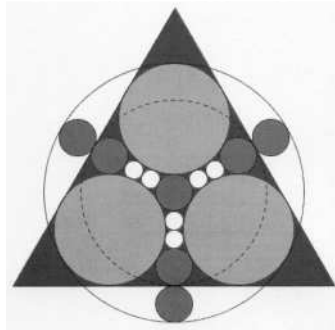

Figure 4.32: Sangaku Geometry [112]

Recreation 27 (Sangaku Geometry [112]). *Figure 4.32 portrays a Sangaku Geometry (“Japanese Temple Geometry”) problem: Express the radius, c , of the small white circles in terms of the radius, r , of the dashed circle. The solution is $c = r/10$ [112, p. 124].*

During Japan’s period of isolation from the West (roughly mid-Seventeenth to mid-Nineteenth Centuries A.D.) imposed by decree of the shogun [242], Sangaku arose which were colored puzzles in Euclidean geometry on wooden tablets that were hung under the roofs of Shinto temples and shrines.

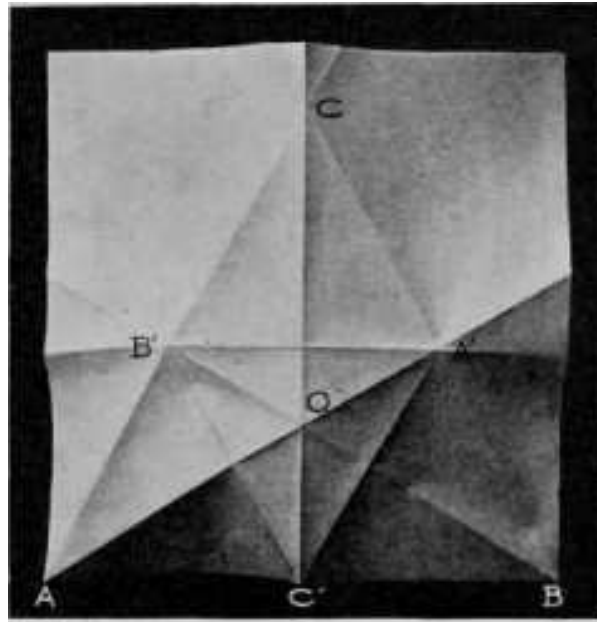

Figure 4.33: Paper Folding [258]

Recreation 28 (Paper Folding [258]). *Paper folding may be used as a pedagogical device to expose even preschoolers to elementary concepts of plane Euclidean geometry [258, p. 13]. Figure 4.33 displays an equilateral triangle so obtained, replete with altitudes, center and pedal triangle.*

Origami, the ancient Japanese art of paper folding, has traditionally focused on forming the shape of natural objects such as animals, birds and fish rather than polygons. Nonetheless, it has long held a particular fascination for many mathematicians such as Lewis Carroll (C. L. Dodgson) [120].



(a)



(b)



(c)

Figure 4.34: Spidrons: (a) Seahorse. (b) Tiling. (c) Polyhedron. [95]

Recreation 29 (Spidrons [242]). *To create a spidron, subdivide an equilateral triangle by connecting its center to its vertices and reflect one of the three resulting $30^\circ - 30^\circ - 120^\circ$ isosceles triangles (with area one-third of the original equilateral triangle) about one of its shorter sides. Now, construct an equilateral triangle on one of the shorter sides (also with area one-third of the original equilateral triangle) and repeat the process of subdivision-reflection-construction. This will produce a spiraling structure with increasingly small components. By deleting the original triangle we arrive at a semi-spidron and joining two of them together results in a spidron which is the seahorse shape of Figure 4.34(a).*

Note that, since $\frac{2}{3} + \frac{2}{9} + \frac{2}{27} + \dots = 2 \cdot \frac{1/3}{1-1/3} = 1$, the sum of the areas of the sequence of triangles following an equilateral triangle in a spidron is equal to the area of the equilateral triangle itself. In other words, an entire semi-spidron was lurking within the original equilateral triangle, waiting to be released! Systems of such spidrons are notable for their ability to generate beautiful tiling patterns in two dimensions (Figure 4.34(b)) and, when folded, splendidly complex polyhedral shapes in three dimensions (Figure 4.34(c)). They were invented in 1979 by graphic artist Dániel Erdély as part of a homework assignment for Ernő Rubik's (of Rubik's Cube fame) Theory of Form class at Budapest University of Art and Design. Possible practical applications of spidrons include acoustic tiles and shock absorbers for machinery. [242].

Chapter 5

Mathematical Competitions

As should be abundantly clear from the previous chapters, the equilateral triangle is a fertile source of mathematical material which requires neither elaborate mathematical technique nor heavy mathematical machinery. As such, it has provided grist for the mill of mathematical competitions such as the American Mathematics Competitions (AMC), USA Mathematical Olympiad (USAMO) and the International Mathematical Olympiad (IMO).

Problem 1 (AMC 1951). *An equilateral triangle is drawn with a side of length of a . A new equilateral triangle is formed by joining the midpoints of the sides of the first one, and so on forever. Show that the limit of the sum of the perimeters of all the triangles thus drawn is $6a$. [262, p. 12]*

Problem 2 (AMC 1952). *Show that the ratio of the perimeter of an equilateral triangle, having an altitude equal to the radius of a circle, to the perimeter of an equilateral triangle inscribed in the circle is $2 : 3$. [262, p. 20]*

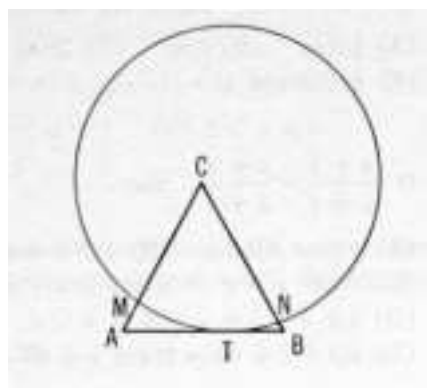

Figure 5.1: AMC 1964

Problem 3 (AMC 1964). In Figure 5.1, the radius of the circle is equal to the altitude of the equilateral triangle ABC . The circle is made to roll along the side AB , remaining tangent to it at a variable point T and intersecting sides AC and BC in variable points M and N , respectively. Let n be the number of degrees in arc MTN . Show that, for all permissible positions of the circle, n remains constant at 60° . [263, p. 36]

Problem 4 (AMC 1967). The side of an equilateral triangle is s . A circle is inscribed in the triangle and a square is inscribed in the circle. Show that the area of the square is $s^2/6$. [264, p. 15]

Problem 5 (AMC 1970). An equilateral triangle and a regular hexagon have equal perimeters. Show that if the area of the triangle is T then the area of the hexagon is $3T/2$. [264, p. 28]

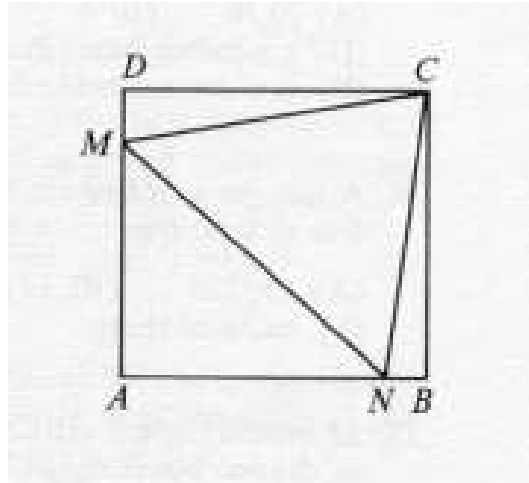

Figure 5.2: AMC 1974

Problem 6 (AMC 1974). In Figure 5.2, $ABCD$ is a unit square and CMN is an equilateral triangle. Show that the area of CMN is equal to $2\sqrt{3} - 3$ square units. [11, p. 11]

Problem 7 (AMC 1976). Given an equilateral triangle with side of length s , consider the locus of all points P in the plane of the triangle such that the sum of the squares of the distances from P to the vertices of the triangle is a fixed number a . Show that this locus is the empty set if $a < s^2$, a single point if $a = s^2$ and a circle if $a > s^2$. [11, p. 24]

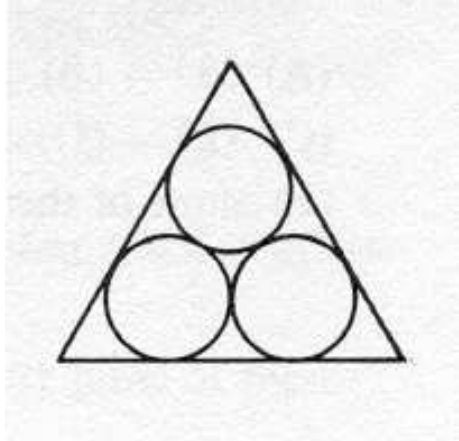

Figure 5.3: AMC 1977

Problem 8 (AMC 1977). *In Figure 5.3, each of the three circles is externally tangent to the other two, and each side of the triangle is tangent to two of the circles. If each circle has radius ρ then show that the perimeter of the triangle is $\rho \cdot (6 + 6\sqrt{3})$. [11, p. 29]*

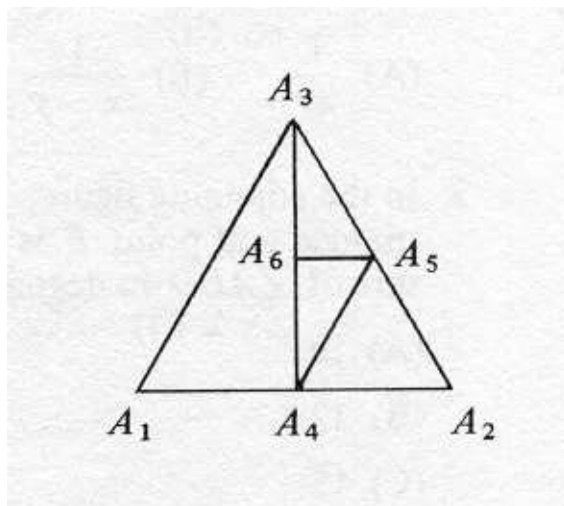

Figure 5.4: AMC 1978

Problem 9 (AMC 1978). *In Figure 5.4, if $\Delta A_1A_2A_3$ is equilateral and A_{n+3} is the midpoint of line segment A_nA_{n+1} for all positive integers n , then show that the measure of $\angle A_{44}A_{45}A_{43}$ equals 120° . [11, p. 39]*

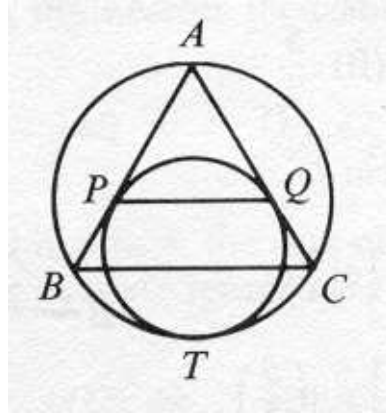

Figure 5.5: AMC 1981

Problem 10 (AMC 1981). In Figure 5.5, equilateral $\triangle ABC$ is inscribed in a circle. A second circle is tangent internally to the circumcircle at T and tangent to sides AB and AC at points P and Q , respectively. Show that the ratio of the length of PQ to the length of BC is $2 : 3$. [11, p. 56]

Problem 11 (AMC 1983). Segment AB is a diameter of a unit circle and a side of an equilateral triangle ABC . The circle also intersects AC and BC at points D and E , respectively. Show that the length of AE is equal to $\sqrt{3}$. [22, p. 2]

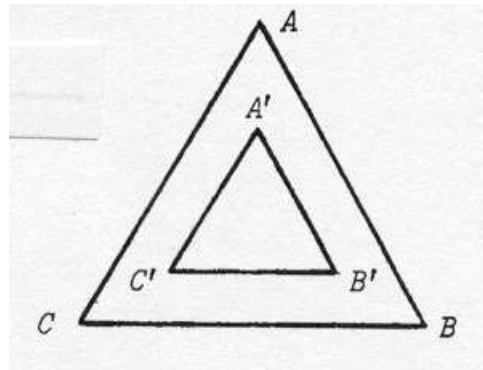

Figure 5.6: AMC 1988

Problem 12 (AMC 1988). In Figure 5.6, ABC and $A'B'C'$ are equilateral triangles with parallel sides and the same center. The distance between side BC and $B'C'$ is $\frac{1}{6}$ the altitude of $\triangle ABC$. Show that the ratio of the area of $\triangle A'B'C'$ to the area of $\triangle ABC$ is $1 : 4$. [22, p. 36]

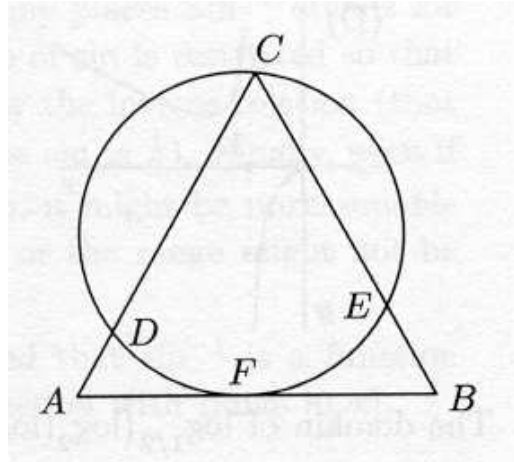

Figure 5.7: AMC 1988D

Problem 13 (AMC 1988D). In Figure 5.7, a circle passes through vertex C of equilateral triangle ABC and is tangent to side AB at point F between A and B . The circle meets AC and BC at D and E , respectively. If $AF/FB = p$ then show that $AD/BE = p^2$. [22, p. 48]

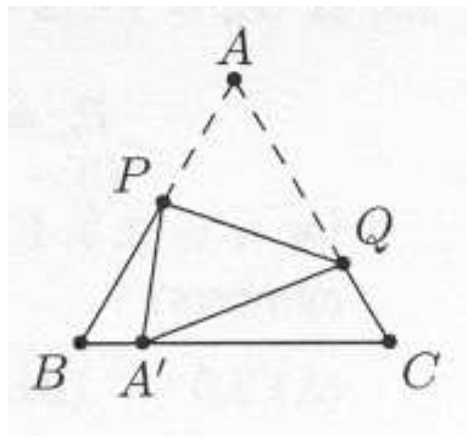

Figure 5.8: AMC 1991

Problem 14 (AMC 1991). In Figure 5.8, equilateral triangle ABC has been creased and folded so that vertex A now rests at A' on \overline{BC} . If $BA' = 1$ and $A'C = 2$ then show that $PQ = \frac{7\sqrt{21}}{20}$. [270, p. 22]

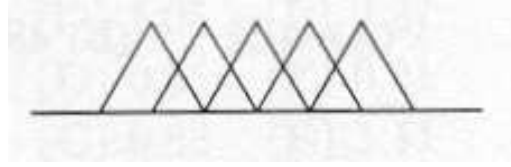

Figure 5.9: AMC 1992

Problem 15 (AMC 1992). In Figure 5.9, five equilateral triangles, each with side $2\sqrt{3}$, are arranged so they are all on the same side of a line containing one side of each. Along this line, the midpoint of the base of one triangle is a vertex of the next. Show that the area of the region of the plane that is covered by the union of the five triangular regions is equal to $12\sqrt{3}$. [270, p. 26]

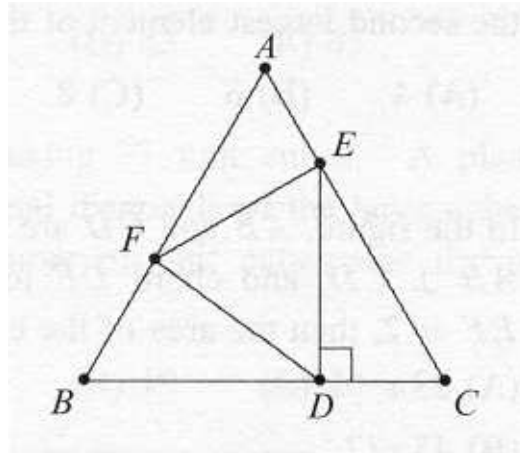

Figure 5.10: AMC 1995

Problem 16 (AMC 1995). In Figure 5.10, equilateral triangle DEF is inscribed in equilateral triangle ABC with $\overline{DE} \perp \overline{BC}$. Show that the ratio of the area of $\triangle DEF$ to the area of $\triangle ABC$ is $1 : 3$. [251, p. 5]

Problem 17 (AMC 1998). A regular hexagon and an equilateral triangle have equal areas. Show that the ratio of the length of a side of the triangle to the length of a side of the hexagon is $\sqrt{6} : 1$. [251, p. 27]

Problem 18 (AMC-10 2003). The number of inches in the perimeter of an equilateral triangle equals the number of square inches in the area of its circumscribed circle. Show that the radius of the circle is $3\sqrt{3}/\pi$. [99, p. 23]

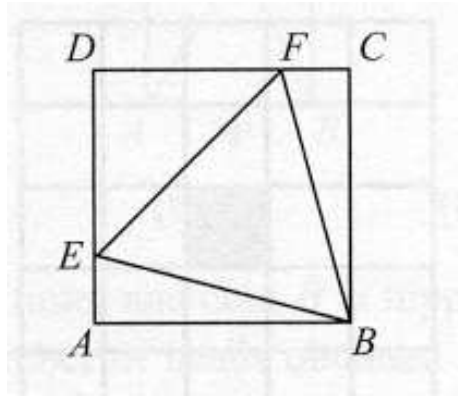

Figure 5.11: AMC-10 2004

Problem 19 (AMC-10 2004). In Figure 5.11, points E and F are located on square $ABCD$ so that $\triangle BEF$ is equilateral. Show that the ratio of the area of $\triangle DEF$ to that of $\triangle ABE$ is $2 : 1$. [99, p. 34]

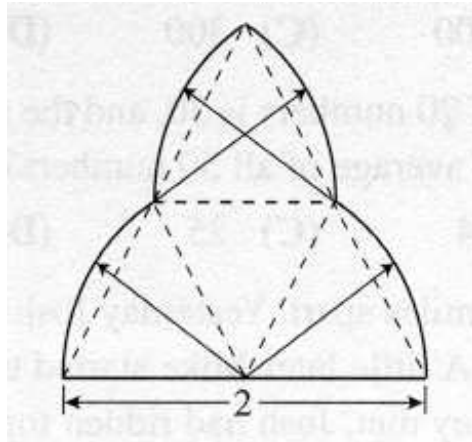

Figure 5.12: AMC-10 2005

Problem 20 (AMC-10 2005). The trefoil shown in Figure 5.12 is constructed by drawing circular sectors about sides of the congruent equilateral triangles. Show that if the horizontal base has length 2 then the area of the trefoil is $\frac{2\pi}{3}$. [99, p. 42]

Problem 21 (AMC-12 2003a). A square and an equilateral triangle have the same perimeter. Let A be the area of the circle circumscribed about the square and B be the area of the circle circumscribed about the triangle. Show that $\frac{A}{B} = \frac{27}{32}$. [323, p. 18]

Problem 22 (AMC-12 2003b). A point P is chosen at random in the interior of an equilateral triangle ABC . Show that the probability that $\triangle ABP$ has a greater area than each of $\triangle ACP$ and $\triangle BCP$ is equal to $\frac{1}{3}$. [323, p. 20]

Problem 23 (AMC-12 2005). All the vertices of an equilateral triangle lie on the parabola $y = x^2$, and one of its sides has a slope of 2. The x -coordinates of the three vertices has a sum of m/n , where m and n are relatively prime positive integers. Show that $m + n = 14$. [323, p. 46]

Problem 24 (AMC-12 2007a). Point P is inside equilateral $\triangle ABC$. Points Q , R and S are the feet of the perpendiculars from P to \overline{AB} , \overline{BC} and \overline{CA} , respectively. Given that $PQ = 1$, $PR = 2$ and $PS = 3$, show that $AB = 4\sqrt{3}$. [323, p. 63]

Problem 25 (AMC-12 2007b). Two particles move along the edges of equilateral $\triangle ABC$ in the direction $A \rightarrow B \rightarrow C \rightarrow A$, starting simultaneously and moving at the same speed. One starts at A and the other starts at the midpoint of \overline{BC} . The midpoint of the line segment joining the two particles traces out a path that encloses a region R . Show that the ratio of the area of R to the area of $\triangle ABC$ is $1 : 16$. [323, p. 64]

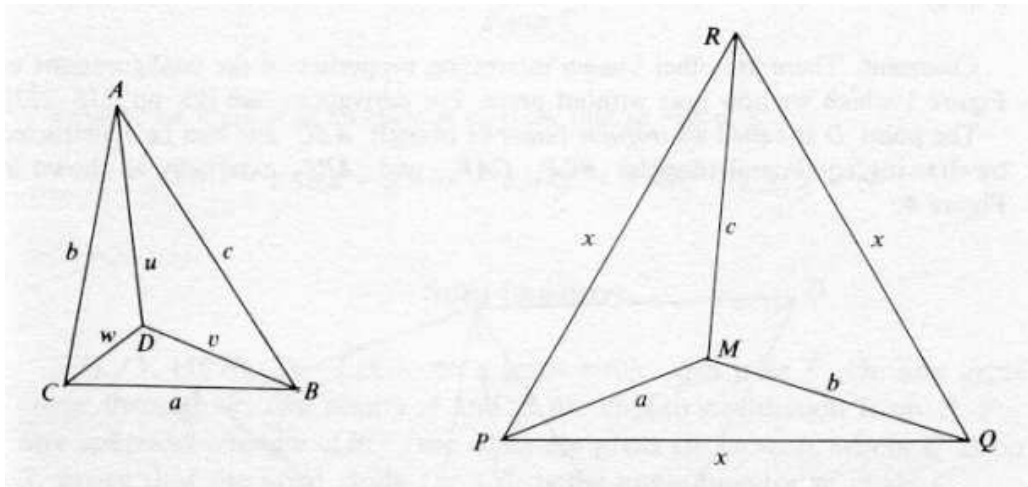

Figure 5.13: USAMO 1974

Problem 26 (USAMO 1974). Consider the two triangles $\triangle ABC$ and $\triangle PQR$ shown in Figure 5.13. In $\triangle ABC$, $\angle ADB = \angle BDC = \angle CDA = 120^\circ$. Prove that $x = u + v + w$. [196, p. 3]

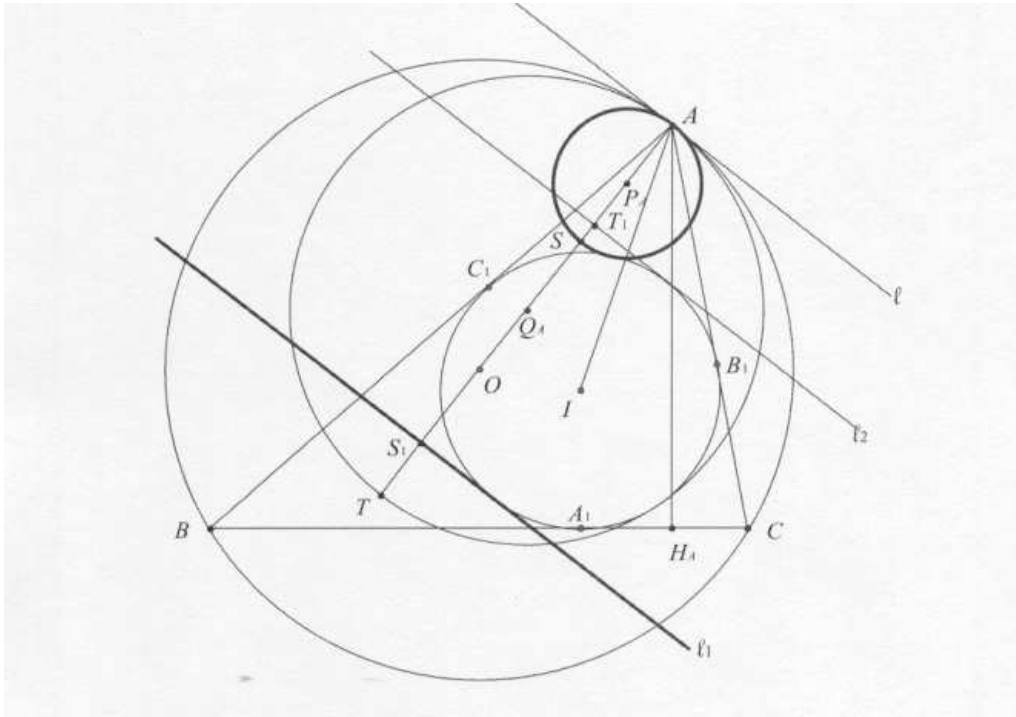

Figure 5.14: USAMO 2007

Problem 27 (USAMO 2007). Let ABC be an acute triangle with ω , Ω , and R being its incircle, circumcircle, and circumradius, respectively (Figure 5.14). Circle ω_A is tangent internally to Ω at A and tangent externally to ω . Circle Ω_A is tangent internally to Ω at A and tangent internally to ω . Let P_A and Q_A denote the centers of ω_A and Ω_A , respectively. Define points P_B, Q_B, P_C, Q_C analogously. Prove that

$$8P_AQ_A \cdot P_BQ_B \cdot P_CQ_C \leq R^3,$$

with equality if and only if triangle ABC is equilateral. [104, p. 28].

Problem 28 (IMO 1961). Let a, b, c be the sides of a triangle, and T its area. Prove: $a^2 + b^2 + c^2 \geq 4\sqrt{3}T$ and that equality holds if and only if the triangle is equilateral. [155, p. 3]

Problem 29 (IMO 1983). Let ABC be an equilateral triangle and \mathcal{E} the set of all points contained in the three segments AB, BC and CA (including A, B and C). Show that, for every partition of \mathcal{E} into two disjoint subsets, at least one of the two subsets contains the vertices of a right-angled triangle. [195, p. 6]

Problem 30 (IMO Supplemental). *Two equilateral triangles are inscribed in a circle with radius r . Let K be the area of the set consisting of all points interior to both triangles. Prove that $K \geq r^2\sqrt{3}/2$. [195, p. 13]*

Problem 31 (IMO 1986). *Given a triangle $A_1A_2A_3$ and a point P_0 in the plane, define $A_s = A_{s-3}$ for all $s \geq 4$. Construct a sequence of points P_1, P_2, P_3, \dots such that P_{k+1} is the image of P_k under rotation with center A_{k+1} through angle 120° clockwise (for $k = 0, 1, 2, \dots$). Prove that if $P_{1986} = P_0$ then the triangle $A_1A_2A_3$ is equilateral. [200, p. 1]*

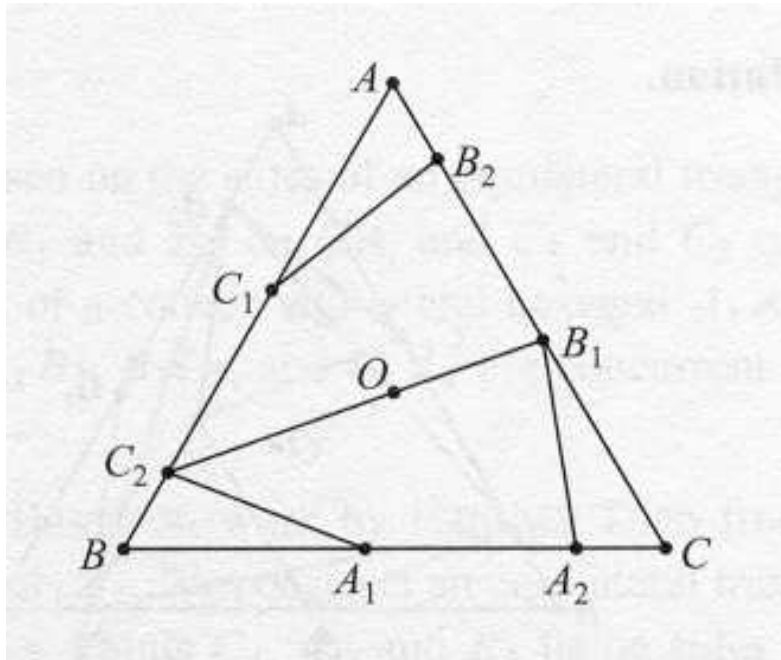

Figure 5.15: IMO 2005

Problem 32 (IMO 2005). *Six points are chosen on the sides of an equilateral triangle ABC : A_1 and A_2 on BC , B_1 and B_2 on CA , and C_1 and C_2 on AB (Figure 5.15). These points are the vertices of a convex equilateral hexagon $A_1A_2B_1B_2C_1C_2$. Prove that lines A_1B_2 , B_1C_2 , and C_1A_2 are concurrent (at the center of the triangle). [103, p. 5]*

Problem 33 (Austrian-Polish Mathematics Competition 1989). *If each point of the plane is colored either red or blue, prove that some equilateral triangle has all its vertices the same color. [182, p. 42]*

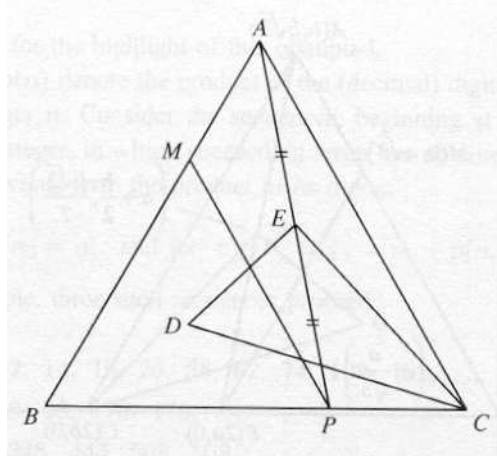

Figure 5.16: All-Union Russian Olympiad 1980

Problem 34 (All-Union Russian Olympiad 1980). *A line parallel to the side AC of equilateral triangle ABC intersects AB at M and BC at P , thus making $\triangle BMP$ equilateral as well (Figure 5.16). Let D be the center of $\triangle BMP$ and E be the midpoint of AP . Show that $\triangle CDE$ is a $30^\circ - 60^\circ - 90^\circ$ triangle. [182, p. 125]*

Problem 35 (Bulgarian Mathematical Olympiad 1998a). *On the sides of a non-obtuse triangle ABC are constructed externally a square, a regular n -gon and a regular m -gon ($m, n > 5$) whose centers form an equilateral triangle. Prove that $m = n = 6$, and find the angles of triangle ABC . (Answer: The angles are $90^\circ, 45^\circ, 45^\circ$.) [7, p. 9]*

Problem 36 (Bulgarian Mathematical Olympiad 1998b). *Let ABC be an equilateral triangle and $n > 1$ be a positive integer. Denote by S the set of $n - 1$ lines which are parallel to AB and divide triangle ABC into n parts of equal area, and by S' the set of $n - 1$ lines which are parallel to AB and divide triangle ABC into n parts of equal perimeter. Prove that S and S' do not share a common element. [7, p. 18]*

Problem 37 (Irish Mathematical Olympiad 1998). *Show that the area of an equilateral triangle containing in its interior a point P whose distances from the vertices are 3, 4, and 5 is equal to $9 + \frac{25\sqrt{3}}{4}$. [7, p. 74]*

Problem 38 (Korean Mathematical Olympiad 1998). *Let D, E, F be points on the sides BC, CA, AB , respectively, of triangle ABC . Let P, Q, R be the second intersections of AD, BE, CF , respectively, with the circumcircle of ABC . Show that $\frac{AD}{PD} + \frac{BE}{QE} + \frac{CF}{RF} \geq 9$, with equality if and only if ABC is equilateral. [7, p. 84]*

Problem 39 (Russian Mathematical Olympiad 1998). *A family S of equilateral triangles in the plane is given, all translates of each other, and any two having nonempty intersection. Prove that there exist three points such that every member of S contains one of the points. [7, p. 136]*

Problem 40 (Bulgarian Mathematical Olympiad 1999). *Each interior point of an equilateral triangle of side 1 lies in one of six congruent circles of radius r . Prove that $r \geq \frac{\sqrt{3}}{10}$. [8, p. 33]*

Problem 41 (French Mathematical Olympiad 1999). *For which acute-angled triangle is the ratio of the shortest side to the inradius maximal? (Answer: The maximum ratio of $2\sqrt{3}$ is attained with an equilateral triangle.) [8, p. 57]*

Problem 42 (Romanian Mathematical Olympiad 1999). *Let $SABC$ be a right pyramid with equilateral base ABC , let O be the center of ABC , and let M be the midpoint of BC . If $AM = 2SO$ and N is a point on edge SA such that $SA = 25SN$, prove that planes ABP and SBC are perpendicular, where P is the intersection of lines SO and MN . [8, p. 119]*

Problem 43 (Romanian IMO Selection Test 1999). *Let ABC be an acute triangle with angle bisectors BL and CM . Prove that $\angle A = 60^\circ$ if and only if there exists a point K on BC ($K \neq B, C$) such that triangle KLM is equilateral. [8, p. 127]*

Problem 44 (Russian Mathematical Olympiad 1999). *An equilateral triangle of side length n is drawn with sides along a triangular grid of side length 1. What is the maximum number of grid segments on or inside the triangle that can be marked so that no three marked segments form a triangle? (Answer: $n(n+1)$.) [8, p. 156]*

Problem 45 (Belarusan Mathematical Olympiad 2000). *In an equilateral triangle of $\frac{n(n+1)}{2}$ pennies, with n pennies along each side of the triangle, all but one penny shows heads. A “move” consists of choosing two adjacent pennies with centers A and B and flipping every penny on line AB . Determine all initial arrangements - the value of n and the position of the coin initially showing tails - from which one can make all the coins show tails after finitely many moves. (Answer: For any value of n , the desired initial arrangements are those in which the coin showing tails is in a corner.) [9, p. 1]*

Problem 46 (Romanian Mathematical Olympiad 2000). *Let $P_1P_2 \cdots P_n$ be a convex polygon in the plane. Assume that, for any pair of vertices P_i, P_j , there exists a vertex V of the polygon such that $\angle P_iVP_j = \pi/3$. Show that $n = 3$, i.e. show that the polygon is an equilateral triangle. [9, p. 96]*

Problem 47 (Turkish Mathematical Olympiad 2000). *Show that it is possible to cut any triangular prism of infinite length with a plane such that the resulting intersection is an equilateral triangle. [9, p. 147]*

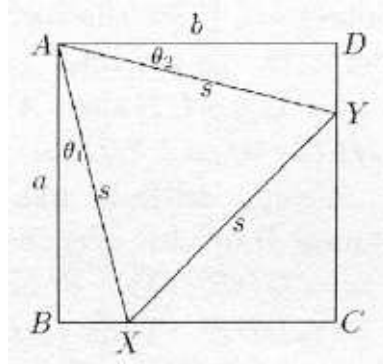

Figure 5.17: Hungarian National Olympiad 1987

Problem 48 (Hungarian National Olympiad 1987). *Cut the equilateral triangle AXY from rectangle $ABCD$ in such a way that the vertex X is on side BC and the vertex Y is on side CD (Figure 5.17). Prove that among the three remaining right triangles there are two, the sum of whose areas equals the area of the third. [306, p. 5]*

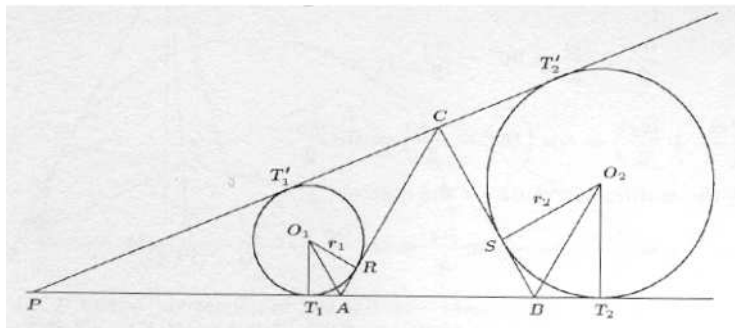

Figure 5.18: Austrian-Polish Mathematics Competition 1993

Problem 49 (Austrian-Polish Mathematics Competition 1993). *Let ΔABC be equilateral. On side AB produced, we choose a point P such that A lies between P and B . We now denote a as the length of sides of ΔABC ; r_1 as the radius of incircle of ΔPAC ; and r_2 as the exradius of ΔPBC with respect to side BC (Figure 5.18). Show that $r_1 + r_2 = \frac{a\sqrt{3}}{2}$. [306, p. 7]*

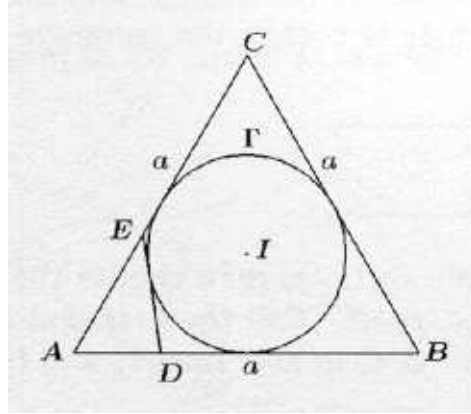

Figure 5.19: Iberoamerican Mathematical Olympiad (Mexico) 1993

Problem 50 (Iberoamerican Mathematical Olympiad (Mexico) 1993).

Let ABC be an equilateral triangle and Γ its incircle (Figure 5.19). If D and E are points of the sides AB and AC , respectively, such that DE is tangent to Γ , show that $\frac{AD}{DB} + \frac{AE}{EC} = 1$. [306, p. 9]

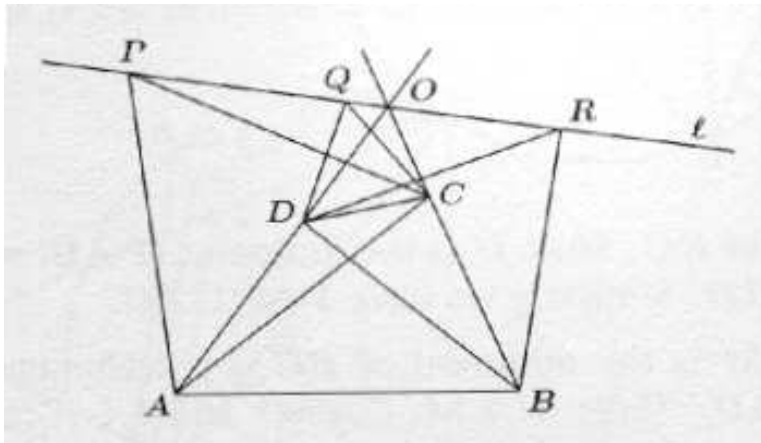

Figure 5.20: Mathematical Olympiad of the Republic of China 1994

Problem 51 (Mathematical Olympiad of the Republic of China 1994).

Let $ABCD$ be a quadrilateral with $AD = BC$ and let $\angle A + \angle B = 120^\circ$. Three equilateral triangles $\triangle ACP$, $\triangle DCQ$ and $\triangle DBR$ are drawn on AC , DC and DB , respectively, away from AB (Figure 5.20). Prove that the three new vertices P , Q and R are collinear. [306, p. 11]

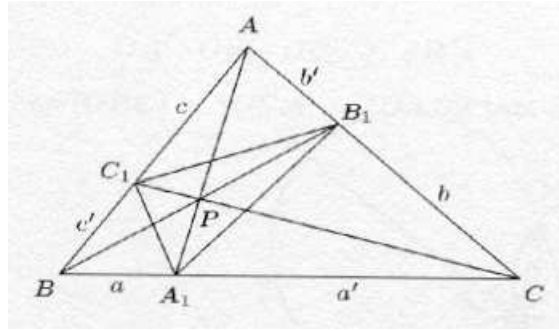

Figure 5.21: International Mathematical Olympiad (Shortlist) 1996a

Problem 52 (International Mathematical Olympiad (Shortlist) 1996a).

Let ABC be equilateral and let P be a point in its interior. Let the lines AP , BP , CP meet the sides BC , CA , AB in the points A_1 , B_1 , C_1 , respectively (Figure 5.21). Prove that

$$A_1B_1 \cdot B_1C_1 \cdot C_1A_1 \geq A_1B \cdot B_1C \cdot C_1A.$$

[306, p. 13]

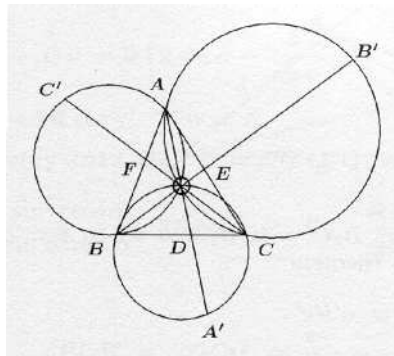

Figure 5.22: International Mathematical Olympiad (Shortlist) 1996b

Problem 53 (International Mathematical Olympiad (Shortlist) 1996b).

Let ABC be an acute-angled triangle with circumcenter O and circumradius R . Let AO meet the circle BOC again in A' , let BO meet the circle COA again in B' , and let CO meet the circle AOB again in C' (Figure 5.22). Prove that

$$OA' \cdot OB' \cdot OC' \geq 8R^3,$$

with equality if and only if ΔABC is equilateral. [306, p. 13]

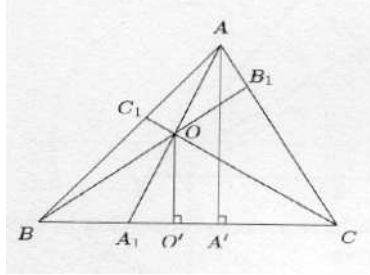

Figure 5.23: Nordic Mathematics Competition 1994

Problem 54 (Nordic Mathematics Competition 1994). Let O be a point in the interior of an equilateral triangle ABC with side length a . The lines AO , BO and CO intersect the sides of the triangle at the points A_1 , B_1 and C_1 , respectively (Figure 5.23). Prove that

$$|OA_1| + |OB_1| + |OC_1| < a.$$

[306, p. 15]

Problem 55 (Latvian Mathematical Olympiad 1997). An equilateral triangle of side 1 is dissected into n triangles. Prove that the sum of squares of all sides of all triangles is at least 3 and that there is equality if and only if the triangle can be dissected into n equilateral triangles. [306, p. 29]

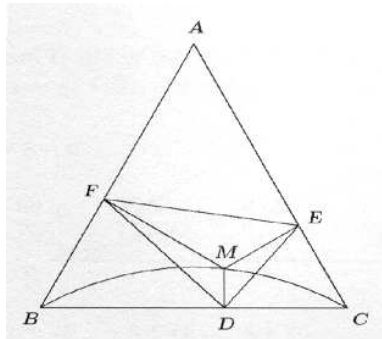

Figure 5.24: Irish Mathematical Olympiad 1997

Problem 56 (Irish Mathematical Olympiad 1997). Let ABC be an equilateral triangle. For a point M inside ABC , let D , E , F be the feet of the perpendiculars from M onto BC , CA , AB , respectively (Figure 5.24). Show that the locus of all such points M for which $\angle FDE$ is a right angle is the arc of the circle interior to $\triangle ABC$ subtending 150° on the line segment BC . [306, p. 31]

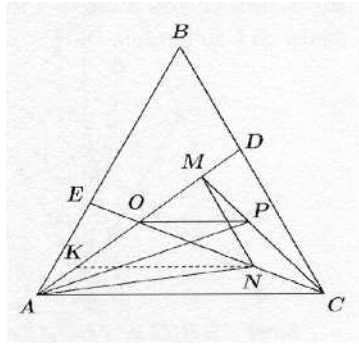

Figure 5.25: Mathematical Olympiad of Moldova 1999a

Problem 57 (Mathematical Olympiad of Moldova 1999a). *On the sides BC and AB of the equilateral triangle ABC , the points D and E , respectively, are taken such that $CD : DB = BE : EA = (\sqrt{5}+1)/2$. The straight lines AD and CE intersect in the point O . The points M and N are interior points of the segments OD and OC , respectively, such that $MN \parallel BC$ and $AN = 2OM$. The parallel to the straight line AC , drawn through the point O , intersects the segment MC in the point P (Figure 5.25). Prove that the half-line AP is the bisectrix of the angle MAN . (Note: This problem is ill-posed in that $AN = 2OM$ cannot be true if the other conditions are true!) [306, p. 44]*

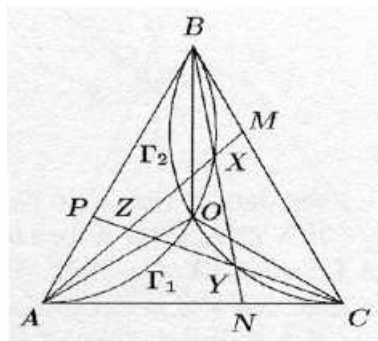

Figure 5.26: Mathematical Olympiad of Moldova 1999b

Problem 58 (Mathematical Olympiad of Moldova 1999b). *On the sides BC , AC and AB of the equilateral triangle ABC , consider the points M , N and P , respectively, such that $AP : PB = BM : MC = CN : NA = \lambda$ (Figure 5.26). Show that the circle with diameter AC covers the triangle bounded by the straight lines AM , BN and CP if and only if $\frac{1}{2} \leq \lambda \leq 2$. (In the case of concurrent straight lines, the triangle degenerates into a point.) [306, p. 44]*

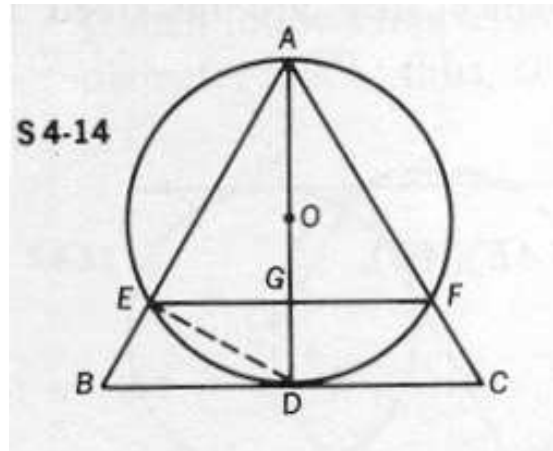

Figure 5.27: Miscellaneous #1

Problem 59 (Miscellaneous #1). *Altitude AD of equilateral $\triangle ABC$ is a diameter which intersects AB and AC at E and F , respectively, as in Figure 5.27. Show that the ratio $EF : BC = 3 : 4$ and that the ratio $EB : BD = 1 : 2$. [246, p. 17]*

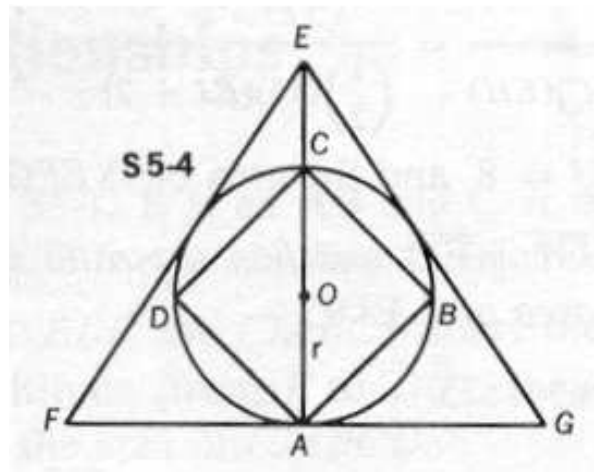

Figure 5.28: Miscellaneous #2

Problem 60 (Miscellaneous #2). *Show that the ratio between the area of a square inscribed in a circle and an equilateral triangle circumscribed about the same circle is equal to $\frac{2\sqrt{3}}{9}$ (Figure 5.28). Also, show that the ratio between the area of a square circumscribed about a circle and an equilateral triangle inscribed in the same circle is equal to $\frac{16\sqrt{3}}{9}$. [246, p. 24]*

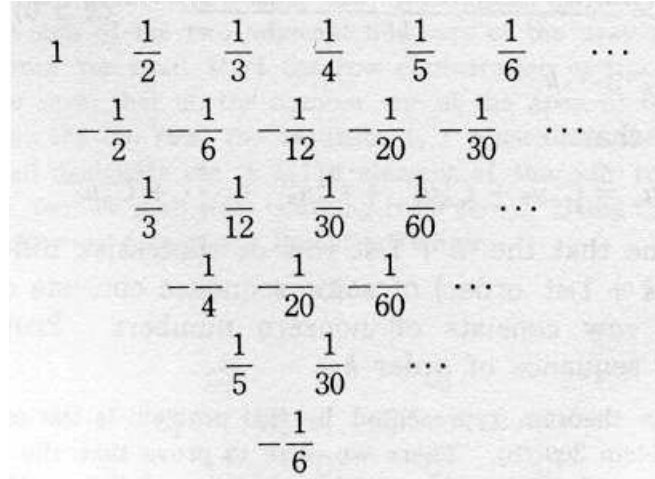

Figure 5.29: Miscellaneous #3

Problem 61 (Miscellaneous #3). Consider the sequence $1, \frac{1}{2}, \frac{1}{3}, \dots, \frac{1}{n}, \dots$ and construct the successive-difference triangle shown in Figure 5.29. Prove that Pascal's triangle results if we turn the displayed triangle 60° clockwise so that 1 appears at the apex, disregard minus signs, and divide through every row by its leading entry. [277, pp. 78-79]

Problem 62 (Curiosa #1). If four equilateral triangles be made the sides of a square pyramid: find the ratio which its volume has to that of a tetrahedron made of the same triangles. (Answer: Two.) [82, p. 11]

Problem 63 (Curiosa #2). Given two equal squares of side 2, in different horizontal planes, having their centers in the same vertical line, and so placed that the sides of each are parallel to the diagonals of the other, and at such a distance apart that, by joining neighboring vertices, 8 equilateral triangles are formed: find the volume of the solid thus enclosed. (Answer: $\frac{8\sqrt[4]{2}(\sqrt{2}+1)}{3}$.) [82, p. 15]

Chapter 6

Biographical Vignettes

In the last decades of the 17th Century, the notable British eccentric, John Aubrey [248], assembled a collection of short biographies [12] which were edited and published two centuries later by Andrew Clark (Figure 6.1). Included were mathematical luminaries such as Briggs, Descartes, Harriot, Oughtred, Pell and Wallis. In the spirit of Aubrey's *Brief Lives*, we conclude our deliberations on the equilateral triangle with a collection of biographical vignettes devoted to some of the remarkable characters that we have encountered along our way.

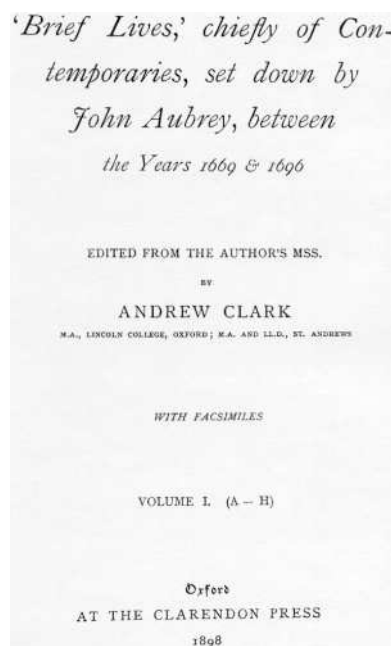

Figure 6.1: Aubrey's *Brief Lives*

Vignette 1 (Pythagoras of Samos: Circa 569-475 B.C.).

Aristotle attributed the motto “All is number.” to Pythagoras more than a century after the death of the latter. Since all of Pythagoras’ writings, if indeed there ever were any, have been lost to us, we have to rely on second-hand sources written much later for details of his life and teachings [148, 165, 233]. Thus, a grain of skepticism is in order when assessing the accuracy of these accounts. Pythagoras was born on the island of Samos off the coast of Ionia (Asia Minor). He had a vast golden birthmark on his thigh which the Greeks believed to be a sign of divinity. He studied Mathematics with Thales and Anaximander in the Ionian city of Miletus and traveled widely in his youth, visiting both Egypt and Babylon and absorbing their knowledge into his evolving philosophy. He eventually settled in Croton in southern Italy where he established a commune with his followers. The Pythagorean brotherhood believed that reality was mathematical in nature and practiced a numerical mysticism which included the tetraktys discussed in Chapter 1 as well as a numerical basis for both music and astronomy. Amongst their mathematical discoveries were irrational numbers, the fact that a polygon with n sides has sum of interior angles equal to $2n - 4$ right angles and sum of exterior angles equal to four right angles, and the five regular solids (although they knew how to construct only the tetrahedron, cube and octahedron). They also were the first to prove the so-called Pythagorean theorem which was known to the Babylonians 1000 years earlier. Due to political turmoil, the Pythagoreans were eventually driven from Croton but managed to set up colonies throughout the rest of Italy and Sicily. Pythagoras died, aged 94, after having returned to Croton.

Vignette 2 (Plato of Athens: 427-347 B.C.).

Plato was born in Athens and studied under Theodorus and Cratylus who was a student of Heraclitus [107, 166, 202]. He served in the military during the Peloponnesian War between Athens and Sparta. After his discharge, he originally desired a political career but had a change of heart after the execution of his mentor, Socrates, in 399 B.C. He then traveled widely visiting Egypt, Sicily and Italy, where he learned of the teachings of Pythagoras. After another stint in the military when he was decorated for bravery in battle, he returned to Athens at age 40 and established his Academy which was devoted to research and instruction in philosophy and science. Plato believed that young men so trained would make wiser political leaders. Counted among the Academy’s graduates were Theaetetus (solid geometry), Eudoxus (doctrine of proportion and method of exhaustion) and Aristotle (philosophy). Above the entrance to the Academy stood a sign “Let no one ignorant of Geometry enter here.”. Plato’s principal writings were his Socratic dialogues wherein he elaborated upon, among other topics, mathematical ideas such as his Theory of

Forms which gave rise to the mathematical philosophy we now call Platonism. Through his emphasis on proof, Plato strongly influenced the subsequent development of Hellenic Mathematics. It was in his *Timaeus* that he propounded a mathematical theory of the composition of the universe on the basis of the five Platonic solids (see Chapter 1). Plato's Academy flourished until 529 A.D. when it was closed by Christian Emperor Justinian as a pagan establishment. At over 900 years, it is the longest known surviving university. Plato died in Athens, aged 80. Source material for Plato is available in [42, 221].

Vignette 3 (Euclid of Alexandria: Circa 325-265 B.C.).

Little is known of the life of Euclid except that he taught at the Library of Alexandria in Egypt circa 300 B.C. [165]. When King Ptolemy asked him if there was an easy way to learn Mathematics, he reportedly replied "There is no royal road to Geometry!". It is likely that he studied in Plato's Academy in Athens since he was thoroughly familiar with the work of Eudoxus and Theaetetus which he incorporated into his masterpiece on geometry and number theory, *The Elements* [164]. This treatise begins with definitions, postulates and axioms and then proceeds to thirteen Books. Books one to six deal with plane geometry (beginning with the construction of the equilateral triangle, see opening of Chapter 1); Books seven to nine deal with number theory; Book ten deals with irrational numbers; and Books eleven through thirteen deal with three-dimensional geometry (ending with the construction of the regular polyhedra and the proof that there are precisely five of them). More than one thousand editions of *The Elements* have been published since it was first printed in 1482. The opening passages of Book I of the oldest extant manuscript of *The Elements* appear in the frontispiece. It was copied by Stephen the Clerk working in Constantinople in 888 A.D. and it now resides in the Bodleian Library of Oxford University. Euclid also wrote *Conics*, a lost work on conic sections that was later extended by Apollonius of Perga. Source material for Euclid is available in [164].

Vignette 4 (Archimedes of Syracuse: 287-212 B.C.).

Archimedes is considered by most, if not all, historians of Mathematics to be one of the greatest (pure or applied) Mathematicians of all time [80, 166]. (I am told that physicists also feel likewise about him.) He was born in Syracuse, Sicily, now part of Italy but then an important Greek city-state. As a young man, he studied with the successors of Euclid in Alexandria but returned to Syracuse for the remainder of his life. Among his many mathematical accomplishments were his use of infinitesimals (method of exhaustion) to calculate areas and volumes, a remarkably accurate approximation to π , and the discovery and proof that a sphere inscribed in a cylinder has two thirds of the volume and surface area of the cylinder. He regarded the latter as his greatest

accomplishment and had a corresponding figure commemorating this discovery placed upon his tomb. The Fields Medal in Mathematics bears both the portrait of Archimedes and the image of a sphere inscribed in a cylinder. His achievements in physics include the foundations of hydrostatics and statics, the explanation of the principle of the lever and the development of the compound pulley to move large weights. In his own lifetime, he was widely known, not for his Mathematics, but rather for his mechanical contrivances, especially his war-machines constructed for his relative, King Hieron of Syracuse. The Archimedes screw is still in use today for pumping liquids and granulated solids such as coal and grain. (There is one in downtown Flint, Michigan!) Many of Archimedes' greatest treatises are lost to us. For example, it is only through the writings of Pappus that we know of his investigation of the thirteen semi-regular polyhedra which now bear his name (see Chapter 1). In 1906, J. L. Heiberg discovered a 10th Century palimpsest containing seven of his treatises including the previously lost *The Method of Mechanical Theorems* wherein this master of antiquity shares with us his secret methods of discovery. The exciting story of the subsequent disappearance and reappearance of *The Archimedes Codex* is told in [226]. He died during the Second Punic War at the siege of Syracuse, aged 75. He reportedly was killed by a Roman soldier after Archimedes told him "Do not disturb my circles!". However, this and other legends surrounding Archimedes, such as his running naked through the streets of Syracuse shouting "Eureka!" after a flash of insight while bathing, must be taken with the proverbial grain of salt. Source material for Archimedes is available in [168].

Vignette 5 (Apollonius of Perga: Circa 262-190 B.C.).

Apollonius, known as 'The Great Geometer', was born in Perga which was a Greek city of great wealth and beauty located on the southwestern Mediterranean coast of modern-day Turkey [166, 167]. Very few details of his life are available but we do know that while still a young man he went to Alexandria to study under the followers of Euclid and later taught there. His works were influential in the subsequent development of Mathematics. For example, his *Conics* introduced the terminology of parabola, ellipse and hyperbola. *Conics* consists of eight books but only the first four, based on a lost work of Euclid, have survived in Greek while the first seven have survived in Arabic. The contents of Books five to seven are highly original and believed to be due primarily to Apollonius himself. Here, he came close to inventing analytic geometry 1800 years before Descartes. However, he failed to account for negative magnitudes and, while his equations were determined by curves, his curves were not determined by equations. Through Pappus, we know of six lost works by Apollonius. In one of these, *Tangencies*, he shows how to construct the circle which is tangent to three given circles (Problem of

Apollonius). Property 16 of Chapter 2 defines Apollonian circles and points. Ptolemy informs us that he was also one of the founders of Greek mathematical astronomy, where he used geometrical models to explain planetary motions. Source material for Apollonius is available in [167].

Vignette 6 (Pappus of Alexandria: Circa 290-350).

Pappus was the last of the great Greek geometers and we know little of his life except that he was born and taught in Alexandria [166]. The 4th Century A.D. was a period of general stagnation in mathematical development (“the Silver Age of Greek Mathematics”). This state of affairs makes Pappus’ accomplishments all the more remarkable. His great work in geometry was called *The Synagoge* or *The Collection* and it is a handbook to be read with the original works intended to revive the classical Greek geometry. It consists of eight Books each of which is preceded by a systematic introduction. Book I, which is lost, was concerned with arithmetic while Book II, which is partially lost, deals with Apollonius’ method for handling large numbers. Book III treats problems in plane and solid geometry including how to inscribe each of the five regular polyhedra in a sphere. Book IV contains properties of curves such as the spiral of Archimedes and the quadratrix of Hippias. Book V compares the areas of different plane figures all having the same perimeter and the volumes of different solids all with the same surface area. This Book also compares the five regular Platonic solids and reveals Archimedes’ lost work on the thirteen semi-regular polyhedra. Book VI is a synopsis and correction of some earlier astronomical works. The preface to Book VII contains Pappus’ Problem (a locus problem involving ratios of oblique distances of a point from a given collection of lines) which later occupied both Descartes and Newton, as well as Pappus’ Centroid Theorem (a pair of related results concerning the surface area and volume of surfaces and solids of revolution). Book VII itself contains Pappus’ Hexagon Theorem (basic to modern projective geometry) which states that three points formed by intersecting six lines connecting two sets of three collinear points are also collinear. It also discusses the lost works of Apollonius previously noted. Book VIII deals primarily with mechanics but intersperses some questions of pure geometry such as how to draw an ellipse through five given points. Overall, *The Collection* is a work of very great historical importance in the study of Greek geometry. Pappus also wrote commentaries on the works of Euclid and Ptolemy. Source material for Pappus is available in [221].

Vignette 7 (Leonardo of Pisa (Fibonacci): 1170-1250).

Leonardo of Pisa, a.k.a. Fibonacci, has been justifiably described as the most talented Western Mathematician of the Middle Ages [143]. Fibonacci was born in Pisa, Italy but was educated in North Africa where his father held

a diplomatic post. He traveled widely with his father and became thoroughly familiar with the Hindu-Arabic numerals and their arithmetic. He returned to Pisa and published his *Liber Abaci* (*Book of Calculation*) in 1202. This most famous of his works is based upon the arithmetic and algebra that he had accumulated in his travels and served to introduce the Hindu-Arabic place-valued decimal system, as well as their numerals, into Europe. An example from *Liber Abaci* involving the breeding of rabbits gave rise to the so-called Fibonacci numbers which he did not discover. (See Property 73 in Chapter 2.) Simultaneous linear equations are also studied in this work. It also contains problems involving perfect numbers, the Chinese Remainder Theorem, and the summation of arithmetic and geometric series. In 1220, he published *Practica geometriæ* which contains a large collection of geometry problems arranged into eight chapters together with theorems and proofs based upon the work of Euclid. This book also includes practical information for surveyors. The final chapter contains “geometrical subtleties” such as inscribing a rectangle and a square in an equilateral triangle! In 1225 he published his mathematically most sophisticated work, *Liber quadratorum*. This is a book on number theory and includes a treatment of Pythagorean triples as well as such gems as: “There are no x, y such that $x^2 + y^2$ and $x^2 - y^2$ are both squares” and “ $x^4 - y^4$ cannot be a square”. This book clearly establishes Fibonacci as the major contributor to number theory between Diophantus and Fermat. He died in Pisa, aged 80. Source material for Fibonacci is available in [42, 297].

Vignette 8 (Leonardo da Vinci: 1452-1519).

Leonardo da Vinci was born the illegitimate son of a wealthy Florentine notary in the Tuscan town of Vinci [44]. He grew up to become one of the greatest painters of all time and perhaps the most diversely talented person ever to have lived. A bona fide polymath, he was painter, sculptor, architect, musician, inventor, anatomist, geologist, cartographer, botanist, writer, engineer, scientist and Mathematician. In what follows, attention is focused on the strictly mathematical contributions dispersed amongst his legacy of more than 7,000 surviving manuscript pages. In Chapter 1, I have already described the circumstances surrounding his illustrations of the Platonic solids for Pacioli’s *De Divina Proportione*. The knowledge of the golden section which he gained through this collaboration is reflected through his paintings. His masterpiece on perspective, *Trattato della Pittura*, opens with the injunction “Let no one who is not a Mathematician read my works.”. This admonition seems more natural when considered together with the observations of Morris Kline: “It is no exaggeration to state that the Renaissance artist was the best practicing Mathematician and that in the fifteenth century he was also the most learned and accomplished theoretical Mathematician.” [197, p. 127]. Leonardo was engaged in rusty compass constructions [97, p. 174] and also gave an innovative congruency-by-subtraction proof of the Pythagorean Theorem [98, p. 29].

He discovered that if a triangle is moved so that one vertex moves along a line while another vertex moves along a second line then the third vertex describes an ellipse [322, p. 65] and this observation is the basis of a commercial instrument for drawing an ellipse using trammels [322, p. 66]. He observed that the angle between an emerging leaf and its predecessor, known as the divergence, is a constant and thereby explained the resulting logarithmic spiral arrangement [139, p. 4]. He was also the first to direct attention to “curves of pursuit” [41, p. 273]. His architectural studies led him to Leonardo’s Symmetry Theorem which states that all planar isometries are either rotations or reflections [327, pp. 66, 99]. The remainder of his mathematical discoveries concerned the areas of lunes, solids of equal volume, reflection in a sphere, inscription of regular polygons and centers of gravity [56, pp. 43-60]. His greatest contribution to geometry came in the latter area where he discovered that the lines joining the vertices of a tetrahedron with the center of gravity of the opposite faces all pass through a point, the centroid, which divides each of these medians in the ratio 3 : 1. These diverse and potent mathematical results have certainly earned Leonardo the title of Mathematician par excellence! He died at the castle of Cloux in Amboise, France, aged 67.

Vignette 9 (Niccolò Fontana (Tartaglia): 1499-1557).

Niccolò Fontana was a Mathematician, engineer, surveyor and bookkeeper who was born in Brescia in the Republic of Venice (now Italy) [144]. Brought up in dire poverty, he became known as Tartaglia (“The Stammerer”) as a result of horrific facial injuries which impeded his speech that he suffered in his youth at the hands of French soldiers. He was widely known during his lifetime for his participation in many public mathematical contests. He became a teacher of Mathematics at Verona in 1521 and moved to Venice in 1534 where he stayed for the rest of his life, except for an 18 month hiatus as Professor at Brescia beginning in 1548. He is best known for his solution to the cubic equation sans quadratic term (which first appeared in Cardano’s *Ars Magna*) but also is known for Tartaglia’s Formula for the volume of a tetrahedron. His first book, *Nuova scienza* (1551), dealt with the theory and practice of gunnery. His largest work, *Trattato generale di numeri e misure* (1556), is a comprehensive mathematical treatise on arithmetic, geometry, mensuration and algebra as far as quadratic equations. It is here that he treated the “three jugs problem” described in Recreation 21 of Chapter 4. He also published the first Italian translation of Euclid (1543) and the earliest Latin version from the Greek of some of the principal works of Archimedes (1543). He died at Venice, aged 58.

Vignette 10 (Johannes Kepler: 1571-1630).

Johannes Kepler was born in the Free Imperial City of Weil der Stadt which is now part of the Stuttgart Region in the German state of Baden-Württemberg

[105]. As a devout Lutheran, he enrolled at the University of Tübingen in 1589 as a student of theology but also studied mathematics and astronomy under Michael Mästlin, one of the leading astronomers of the time, who converted him to the Copernican view of the cosmos. At the end of his university studies in 1594, he abandoned his plans for ordination (in fact, he was excommunicated in 1612) and accepted a post teaching Mathematics in Graz. In 1596, he published *Mysterium cosmographicum* where he put forth a model of the solar system based upon inscribing and circumscribing each of the five Platonic solids by spherical orbs. On this basis, he moved to Prague in 1600 as Tycho Brahe's mathematical assistant and began work on compiling the Rudolphine Tables. In 1601, upon Tycho's death, he succeeded him as Imperial Mathematician and the next eleven years proved to be the most productive of his life. Kepler's primary obligations were to provide astrological advice to Emperor Rudolph II and to complete the Rudolphine Tables. In 1604, he published *Astronomiae pars optica* where he presented the inverse-square law governing the intensity of light, treated reflection by flat and curved mirrors and elucidated the principles of pinhole cameras (*camera obscura*), as well as considered the astronomical implications of optical phenomena such as parallax and the apparent sizes of heavenly bodies. He also considered the optics of the human eye, including the inverted images formed on the retina. That same year, he wrote of a "new star" which is today called Kepler's supernova. In 1609, he published *Astronomia nova* where he set out his first two laws of planetary motion based upon his observations of Mars. In 1611, he published *Dioptrice* where he studied the properties of lenses and presented a new telescope design using two convex lenses, now known as the Keplerian telescope. That same year, he moved to Linz to avoid religious persecution and, as a New Year's gift for his friend and sometimes patron Baron von Wackhenfels, published a short pamphlet, *Strena Seu de Nive Sexangula*, where he described the hexagonal symmetry of snowflakes and posed the Kepler Conjecture about the most efficient arrangement for packing spheres. Kepler's Conjecture was solved only after almost 400 years by Thomas Hales [301]! In 1615, he published a study of the volumes of solids of revolution to measure the contents of wine barrels, *Nova stereometria doliorum vinariorum*, which is viewed today as an ancestor of the infinitesimal calculus. In 1619, Kepler published his masterpiece, *Harmonice Mundi*, which not only contains Kepler's Third Law, but also includes the first systematic treatment of tessellations, a proof that there are only thirteen Archimedean solids (he provided the first known illustration of them as a set and gave them their modern names), and two new non-convex regular polyhedra (Kepler's solids). In 1624 and 1625, he published an explanation of how logarithms worked and he included eight-figure logarithmic tables with the Rudolphine Tables which were finally published in 1628. In that year, he left the service of the Emperor and became an advisor to General Wallenstein.

He fell ill while visiting Regensburg, Bavaria and died, aged 58. (His tomb was destroyed in the course of the Thirty Years' War.) *Somnium* (1634), which was published posthumously, aimed to show the feasibility of a non-geocentric system by describing what practicing astronomy would be like from the perspective of another planet. Kepler's work on regular and semiregular tilings of the plane was mentioned in Chapter 1 as was the likelihood that he was a Rosicrucian. Source material for Kepler is available in [42].

Vignette 11 (René Descartes: 1596-1650).

René Descartes, the Father of Modern Philosophy, was born in La Haye en Touraine (now renamed Descartes), Indre-et-Loire, France [3]. He was educated at the Jesuit College of La Flèche in Anjou until 1612. He received a law degree from the University of Poitiers in 1616 and then enlisted in the military school at Breda in the Dutch Republic. Here he met the Dutch scientist Isaac Beeckman with whom he began studying mechanics and Mathematics in 1618, then, in 1619, he joined the Bavarian army. From 1620 to 1628, he wandered throughout Europe, spending time in Bohemia (1620), Hungary (1621), Germany, Holland and France (1622-23). In 1623, he met Marin Mersenne in Paris, an important contact which kept him in touch with the scientific world for many years. From Paris, he travelled to Italy where he spent some time in Venice, then he returned to France again (1625). In 1628, he chose to settle down in Holland for the next twenty years. In 1637, he published a scientific treatise, *Discours de la méthode*, which included a treatment of the tangent line problem which was to provide the basis for the calculus of Newton and Leibniz. It also contained among its appendices his masterpiece on analytic geometry, *La Géométrie*, which includes Descartes' Rule of Signs for determining the number of positive and negative real roots of a polynomial. In another appendix, on optics, he independently discovered Snell's law of reflection. In 1644, he published *Principia Philosophiae* where he presented a mathematical foundation for mechanics that included a vortex theory as an alternative to action at a distance. In 1649, Queen Christina of Sweden persuaded him to move to Stockholm, where he died of pneumonia, aged 53. Descartes' proficiency at bare-knuckled brawling is revealed by his response to criticism of his work by Fermat: he asserted euphemistically that he was "full of shit" [169, p. 38]. Descartes' role in the discovery of the polyhedral formula was mentioned in Chapter 1 as was the likelihood that he was a Rosicrucian. Source material for Descartes is available in [42, 77, 221, 287, 297].

Vignette 12 (Pierre de Fermat: 1601-1665).

Pierre de Fermat, lawyer and Mathematician, was born in Beaumont-de-Lomagne, France [216]. He began his studies at the University of Toulouse

before moving to Bordeaux where he began his first serious mathematical researches. He received his law degree from the University of Orleans in 1631 and received the title of councillor at the High Court of Judicature in Toulouse, which he held for the rest of his life. For the remainder of his life, he lived in Toulouse while also working in his home town of Beaumont-de-Lomagne and the nearby town of Castres. Outside of his official duties, Fermat was preoccupied with Mathematics and he communicated his results in letters to his friends, especially Marin Mersenne, often with little or no proof of his theorems. He developed a method for determining maxima, minima and tangents to various curves that was equivalent to differentiation. He also developed a technique for finding centers of gravity of various plane and solid figures that led him to further work in quadrature. In number theory, he studied Pell's equation, perfect numbers (where he discovered Fermat's Little Theorem), amicable numbers and what would later become known as Fermat numbers. He invented Fermat's Factorization Method and the technique of infinite descent which he used to prove Fermat's Last Theorem for $n = 4$. (Fermat's Last Theorem [19] was finally resolved, after more than 350 years, by Andrew Wiles [283]!) He drew inspiration from Diophantus, but was interested only in integer solutions to Diophantine equations, and he looked for all possible solutions. Through his correspondence with Pascal, he helped lay the fundamental groundwork for the theory of probability. Fermat's Principle of Least Time (which he used to derive Snell's Law) was the first variational principle enunciated in more than 1,500 years. See Property 12 for a definition of the Fermat point and Property 39 for a discussion of Fermat's Polygonal Number Conjecture. He died in Castres, France, aged 57. Source material for Fermat is available in [42, 287, 297].

Vignette 13 (Evangelista Torricelli: 1608-1647).

Evangelista Torricelli was a physicist and Mathematician born in Faenza, part of the Papal States [144]. He went to Rome in 1627 to study science under the Benedictine Benedetto Castelli, Professor of Mathematics at the Collegio della Sapienza. He then served for nine years as secretary to Giovanni Ciampoli, a friend of Galileo. In 1641, Torricelli moved to Arcetri where Galileo was under house arrest and worked with him and Viviani for a few months prior to Galileo's death. He was then appointed to succeed Galileo as Court Mathematician to Grand Duke Ferdinando II de' Medici of Tuscany. He held this post until his death living in the ducal palace in Florence. In 1644, the *Opera geometrica* appeared, his only work to be published during his lifetime. He examined the three dimensional figures obtained by rotating a regular polygon about an axis of symmetry, computed the center of gravity of the cycloid and extended Cavalieri's (another pupil of Castelli) method of indivisibles. Torricelli was the first person to create a sustained vacuum or to

give the correct scientific explanation of the cause of the wind (differences of air temperature and density) and he discovered the principle of the mercury barometer. He was a skilled lens grinder and made excellent telescopes and microscopes. The Fermat-Torricelli Problem/Point has already been discussed at length in Property 12 of Chapter 2. (This problem was solved by Torricelli and Cavalieri for triangles of less than 120° and the general case was solved by Viviani.) Torricelli's Trumpet (Gabriel's Horn) is a figure with infinite surface area yet finite volume. Torricelli's Law/Theorem relates the speed of fluid flowing out of an opening to the height of the fluid above the opening ($v = \sqrt{2gh}$). Torricelli's Equation provides the final velocity of an object moving with constant acceleration without having a known time interval ($v_f^2 = v_i^2 + 2a\Delta d$). He died in Florence, aged 39, shortly after having contracted typhoid fever. Viviani agreed to prepare his unpublished materials for posthumous publication but he failed to accomplish this task, which was not completed until 1944 nearly 300 years after Torricelli's death. Source material for Torricelli is available in [297].

Vignette 14 (Vincenzo Viviani: 1622-1703).

Vincenzo Viviani, the last pupil of Galileo, was born in Florence, Italy [144]. His exceptional mathematical abilities brought him to the attention of Grand Duke Ferdinando II de' Medici of Tuscany in 1638 who introduced him to Galileo. In 1639, at the age of 17, he became Galileo's assistant at Arcetri until the latter's death in 1642. During this period, he met Torricelli and they later became collaborators on the development of the barometer. (He was Torricelli's junior colleague not his student although he collected and arranged his works after the latter's death.) The Grand Duke then appointed him Mathematics teacher at the ducal court and engaged him as an engineer with the Ufficiali dei Fiumi, a position he held for the rest of his life. From 1655 to 1656, he edited the first edition of Galileo's collected works and he also wrote the essay *Life of Galileo* which was not published in his lifetime. In 1660, he and Giovanni Alfonso Borelli conducted an experiment involving timing the difference between seeing the flash and hearing the sound of a cannon shot at a distance which provided an accurate determination of the speed of sound. In 1661, he experimented with rotation of pendula, 190 years before the famous demonstration by Foucault. In 1666, the Grand Duke appointed him Court Mathematician. Throughout his life, one of his main interests was ancient Greek Mathematics and he published reconstructions of lost works of Euclid and Apollonius and also translated a work of Archimedes into Italian. He calculated the tangent to the cycloid and also contributed to constructions involving angle trisection and duplication of the cube. Viviani's Theorem has been previously described in Property 8 of Chapter 2. Viviani's Curve is a space curve obtained by intersecting a sphere with a circular cylinder tangent

to the sphere and to one of its diameters, a sort of spherical figure eight [38]. Viviani proposed the architectural problem (“Florentine enigma”): Build on a hemispherical cupola four equal windows of such a size that the remaining surface can be exactly squared. The Viviani Window is a solution: The four windows are the intersections of a hemisphere of radius a with two circular cylinders of radius $\frac{a}{2}$ that have in common only a ruling containing a diameter of the hemisphere [38]. He provided the complete solution to the Fermat-Torricelli Problem (see Property 12 in Chapter 2). In 1687, he published a book on engineering, *Discorso* and, upon his death in Florence, aged 81, he left an almost completed work on the resistance of solids which was subsequently completed and published by Luigi Guido Grandi.

Vignette 15 (Blaise Pascal: 1623-1662).

Blaise Pascal, philosopher, physicist and Mathematician, was born in Clermont, Auvergne, France [25, 40]. At age 14, he began to accompany his father to Mersenne’s meetings of intellectuals which included Roberval and Desargues. Except for this influence, he was essentially self-taught. At one such meeting, at the age of sixteen, he presented a number of theorems in projective geometry, including Pascal’s Mystic Hexagram Theorem. In 1639, he and his family moved to Rouen and, in 1640, Pascal published his first work, *Essay on Conic Sections*. Pascal invented the first digital calculator, the Pascaline, to help his father with his work collecting taxes. In 1647, he published *New Experiments Concerning Vacuums* where he argued for the existence of a pure vacuum and observed that atmospheric pressure decreases with height thereby deducing that a vacuum existed above the atmosphere. In 1653, he published *Treatise on the Equilibrium of Liquids* in which he introduced what is now known as Pascal’s Law of Pressure. (He also invented the hydraulic press and the syringe.) In a lost work (we know of its contents because Leibniz and Tschirnhaus had made notes from it), *The Generation of Conic Sections*, he presented important theorems in projective geometry. His 1653 work, *Treatise on the Arithmetical Triangle*, was to lead Newton to his discovery of the generalized binomial theorem for fractional and negative powers. (Pascal’s triangle is described in more detail in Property 61 of Chapter 2.) In the summer of 1654, he exchanged letters with Fermat where they laid the foundations of the theory of probability. In the fall of the same year, he had a near-death experience which led him to devote his remaining years to religious pursuits, specifically Jansenism. (At which time, he devised Pascal’s Wager.) Thus, with the exception of a 1658 study of the quadrature of the cycloid, his scientific and mathematical investigations were concluded, at age 31. The SI unit of pressure and a programming language are named after him. He died in intense pain, aged 39, in Paris, France, after a malignant growth in his stomach spread to his brain. Source material for Pascal is available in [42, 287, 297].

Vignette 16 (Isaac Newton: 1643-1727).

Isaac Newton was born in the manor house of Woolsthorpe, near Grantham in Lincolnshire, England [298, 324, 328]. Because England had not yet adopted the Gregorian calendar, his birth was recorded as Christmas Day, 25 December 1642. While he showed some mechanical ability as a young man, his mathematical precocity did not appear until he was a student at Trinity College, Cambridge where he enrolled in 1661. He was elected a scholar in 1664 and received his bachelor's degree in 1665. When the University closed in the summer of 1665 due to the plague, Newton returned to Woolsthorpe for the next two years, during which time he developed calculus, performed optical experiments and discovered the universal law of gravitation. When the University opened again in 1667, he was elected to a minor fellowship at Trinity College but, after being awarded his master's degree, he was elected to a major fellowship in 1668. In 1669, Isaac Barrow, the Lucasian Professor of Mathematics, began to circulate Newton's tract on infinite series, *De Analysi*, so that, when he stepped down that same year, Newton was chosen to fill the Lucasian Chair. Newton then turned his attention to optics and constructed a reflecting telescope which led to his election as a Fellow of the Royal Society. In 1672, he published his first scientific paper on light and colour where he proposed a corpuscular theory. This received heavy criticism by Hooke and Huyghens who favored a wave theory. Because of the ensuing controversy, Newton became very reluctant to publish his later discoveries. However, in 1687, Halley convinced him to publish his greatest work *Philosophiæ naturalis principia mathematica*. *Principia* contained his three laws of motion and the inverse square law of gravitation, as well as their application to orbiting bodies, projectiles, pendula, free-fall near the Earth, the eccentric orbits of comets, the tides and their variations, the precession of the Earth's axis, and the motion of the Moon as perturbed by the gravity of the Sun. It has rightfully been called the greatest scientific treatise ever written! His other mathematical contributions include the generalized binomial theorem, Newton's method for approximating the roots of a function, Newton's identities relating the roots and coefficients of polynomials, the classification of cubic curves, the theory of finite differences and the Newton form of the interpolating polynomial. His other contributions to physics include the formulation of his law of cooling and a study of the speed of sound. However, to maintain a proper perspective, one must bear in mind that Newton wrote much more on Biblical and alchemical topics than he ever did in physics and Mathematics! In 1693, he left Cambridge to become first Warden and then Master of the Mint. In 1703 he was elected President of the Royal Society and was re-elected each year until his death. In 1705, he was knighted by Queen Anne (the first scientist to be so honored). In his later years, he was embroiled in a bitter feud with Leibniz over priority for the invention of calculus [169]. He died in his sleep in London, aged 84, and

was buried in Westminster Abbey. Chapter 1 noted how Newton patterned his *Principia* after Euclid's *The Elements* and alluded to his alchemical activities. Source material for Newton is available in [42, 221, 227, 287, 297].

Vignette 17 (Leonhard Euler: 1707-1783).

Leonhard Euler was born in Basel, Switzerland and entered the University of Basel at age 14 where he received private instruction in Mathematics from the eminent Mathematician Johann Bernoulli [102]. He received his Master of Philosophy in 1723 with a dissertation comparing the philosophies of Descartes and Newton. In 1726, he completed his Ph.D. with a dissertation on the propagation of sound and published his first paper on isochronous curves in a resisting medium. In 1727, he published another paper on reciprocal trajectories [265, pp. 6-7] and he also won second place in the Grand Prize competition of the Paris Academy for his essay on the optimal placement of masts on a ship. He subsequently won first prize twelve times in his career. Also in 1727, he wrote a classic paper in acoustics and accepted a position in the mathematical-physical section of the St. Petersburg Academy of Sciences where he was a colleague of Daniel Bernoulli, son of Euler's teacher in Basel. During this first period in St. Petersburg, his research was focused on number theory, differential equations, calculus of variations and rational mechanics. In 1736-37, he published his book *Mechanica* which presented Newtonian dynamics in the form of mathematical analysis and, in 1739, he laid a mathematical foundation for music. In 1741, he moved to the Berlin Academy. During the twenty five years that he spent in Berlin, he wrote 380 articles and published books on calculus of variations, the calculation of planetary orbits, artillery and ballistics, analysis, shipbuilding and navigation, the motion of the moon, lectures on differential calculus and a popular scientific publication, *Letters to a Princess of Germany*. In 1766, he returned to St. Petersburg where he spent the rest of his life. Although he lost his sight, more than half of his total works date to this period, primarily in optics, algebra and lunar motion, and also an important work on insurance. To Euler, we owe the notation $f(x)$, e , i , π , Σ for sums and $\Delta^n y$ for finite differences. He solved the Basel Problem $\Sigma(1/n^2) = \pi^2/6$, proved the connection between the zeta function and the sequence of prime numbers, proved Fermat's Last Theorem for $n = 3$, and gave the formula $e^{i\theta} = \cos \theta + i \cdot \sin \theta$ together with its special case $e^{i\pi} + 1 = 0$. The list of his important discoveries that I have not included is even longer! As Laplace advised, "Read Euler, read Euler, he is the master of us all.". Euler was the most prolific Mathematician of all time with his collected works filling between 60-80 quarto volumes. See Chapter 1 for a description of Euler's role in the discovery of the Polyhedral Formula, Property 28 for the definition of the Euler line, Property 47 for the statement of Euler's inequality and Recreation 25 for his investigation of the Knight's Tour. He has been featured on the

Swiss 10-franc banknote and on numerous Swiss, German and Russian stamps. As part of their Tercentenary Euler Celebration, the Mathematical Association of America published a five volume tribute [265, 89, 266, 27, 32]. He died in St. Petersburg, Russia, aged 76. Source material for Euler is available in [42, 287, 297].

Vignette 18 (Gian Francesco Malfatti: 1731-1807).

Gian Francesco Malfatti was born in Ala, Trento, Italy but studied at the College of San Francesco Saverio in Bologna under Francesco Maria Zanotti, Gabriele Manfredi and Vincenzo Riccati (Father of Hyperbolic Functions) [144]. He then went to Ferrara in 1754, where he founded a school of Mathematics and physics. In 1771, when the University of Ferrara was reestablished, he was appointed Professor of Mathematics, a position he held for approximately thirty years. In 1770, he worked on the solution of the quintic equation where he introduced the Malfatti resolvent. In 1781, he demonstrated that the lemniscate has the property that a point mass moving on it under gravity goes along any arc of the curve in the same time as it traverses the subtending chord. In 1802 he gave the first, brilliant solution of the problem which bears his name: Describe in a triangle three circles that are mutually tangent, each of which touches two sides of the triangle (see Property 70 in Chapter 2). He also made fundamental contributions to probability, mechanics, combinatorial analysis and to the theory of finite difference equations. He died in Ferrara, aged 76.

Vignette 19 (Joseph-Louis Lagrange: 1736-1813).

Joseph-Louis Lagrange was born in Turin, Italy and educated at the College of Turin where he showed little interest in Mathematics until reading, at age seventeen, a paper by Edmond Halley on the use of algebra in optics [151]. He then devoted himself to the study of Mathematics. Although he was essentially self-taught and did not have the benefit of studying with leading Mathematicians, he was made a Professor of Mathematics at the Royal Artillery School in Turin at age nineteen. His first major work was on the tautochrone (the curve on which a particle will always arrive at a fixed point in the same time independent of its initial position) where he discovered a method for extremizing functionals which became one of the cornerstones of calculus of variations. In 1757, Lagrange was one of the founding members of what was to become the Royal Academy of Sciences in Turin. Over the next few years, he published diverse papers in its transactions on calculus of variations (including Lagrange multipliers), calculus of probabilities and foundations of mechanics based upon the Principle of Least Action. He made a major study of the propagation of sound where he investigated the vibrating string using a discrete mass model with the number of masses approaching

infinity. He also studied the integration of differential equations and fluid mechanics where he introduced the Lagrangian function. In 1764, he submitted a prize essay to the French Academy of Sciences on the libration of the moon containing an explanation as to why the same face is always turned towards Earth which utilized the Principle of Virtual Work and the idea of generalized equations of motion. In 1766, Lagrange succeeded Euler as the Director of Mathematics at the Berlin Academy where he stayed until 1787. During the intervening 20 years, he published a steady stream of top quality papers and regularly won the prize from the Académie des Sciences in Paris. These papers covered astronomy, stability of the solar system, mechanics, dynamics, fluid mechanics, probability and the foundation of calculus. His work on number theory in Berlin included the Four Squares Theorem and Wilson's Theorem (n is prime if and only if $(n - 1)! + 1$ is divisible by n). He also made a fundamental investigation of why equations of degree up to 4 can be solved by radicals and studied permutations of their roots which was a first step in the development of group theory. However, his greatest achievement in Berlin was the preparation of his monumental work *Traité de mécanique analytique* (1788) which presented from a unified perspective the various principles of mechanics, demonstrating their connections and mutual dependence. This work transformed mechanics into a branch of mathematical analysis. In 1787, he left Berlin to accept a non-teaching post at the Académie des Sciences in Paris where he stayed for the rest of his career. He was a member of the committee to standardize weights and measures that recommended the adoption of the metric system and served on the Bureau des Longitudes which was charged with the improvement of navigation, the standardization of time-keeping, geodesy and astronomical observation. His move to Paris signalled a marked decline in his mathematical productivity with his single notable achievement being his work on polynomial interpolation. See Property 39 for a description of his contribution to the Polygonal Number Theorem and Applications 7&8 for a summary of his research on the Three-Body Problem. He died and was buried in the Panthéon in Paris, aged 77, before he could finish a thorough revision of *Mécanique analytique*. Source material for Lagrange is available in [23, 42, 297].

Vignette 20 (Johann Karl Friedrich Gauss: 1777-1855).

Karl Friedrich Gauss, *Princeps mathematicorum*, was born to poor working-class parents in Braunschweig in the Electorate of Brunswick-Lüneburg of the Holy Roman Empire now part of Lower Saxony, Germany [36, 90, 160]. He was a child prodigy, correcting his father's financial calculations at age 3 and discovering the sum of an arithmetic series in primary school. His intellectual abilities attracted the attention and financial support of the Duke of Braunschweig, who sent him to the Collegium Carolinum (now Technische Univer-

sität Braunschweig), which he attended from 1792 to 1795, and to the University of Göttingen from 1795 to 1798. His first great breakthrough came in 1796 when he showed that any regular polygon with a number of sides which is a Fermat prime can be constructed by compass and straightedge. This achievement led Gauss to choose Mathematics, which he termed the Queen of the Sciences, as his life's vocation. Gauss was so enthused by this discovery that he requested that a regular heptadecagon (17 sided polygon) be inscribed on his tombstone, a request that was not fulfilled because of the technical challenge which it posed. He returned to Braunschweig in 1798 without a degree but received his doctorate in absentia from the University of Helmstedt in 1799 with a dissertation on the Fundamental Theorem of Algebra under the nominal supervision of J. F. Pfaff. With the Duke's stipend to support him, he published, in 1801, his magnum opus *Disquisitiones Arithmeticae*, a work which he had completed in 1798 at age 21. *Disquisitiones Arithmeticae* summarized previous work in a systematic way, resolved some of the most difficult outstanding questions, and formulated concepts and questions that set the pattern of research for a century and that still have significance today. It is here that he introduced modular arithmetic and proved the law of quadratic reciprocity as well as appended his work on constructions with compass and straightedge. In this same year, 1801, he predicted the orbit of Ceres with great accuracy using the method of least squares, a feat which brought him wide recognition. With the Duke's death, he left Braunschweig in 1807 to take up the position of director of the Göttingen observatory, a post which he held for the rest of his life. In 1809, he published *Theoria motus corporum coelestium*, his two volume treatise on the motion of celestial bodies. His involvement with the geodetic survey of the state of Hanover (when he invented the heliotrope) led to his interest in differential geometry. Here, he contributed the notion of Gaussian curvature and the *Theorema Egregium* which informally states that the curvature of a surface can be determined entirely by measuring angles and distances on the surface, i.e. curvature of a two-dimensional surface does not depend on how the surface is embedded in three-dimensional space. With Wilhelm Weber, he investigated terrestrial magnetism, discovered the laws of electric circuits, developed potential theory and invented the electromechanical telegraph. His work for the Göttingen University widows' fund is considered part of the foundation of actuarial science. Property 38 describes the equilateral triangle in the Gauss plane and Property 39 states Gauss' Theorem on Triangular Numbers. Although not enamored with teaching, he counted amongst his students such luminaries as Bessel, Dedekind and Riemann. The CGS unit of magnetic induction is named for him and his image was featured on the German Deutschmark as well as on three stamps. Gauss was not a prolific writer, which is reflected in his motto *Pauca sed matura* ("Few, but ripe"). What he did publish may best be described as terse, in keeping with his belief

that a skilled artisan should always remove the scaffolding after a masterpiece is finished. His personal diaries contain several important mathematical discoveries, such as non-Euclidean geometry, that he had made years or decades before his contemporaries published them. He died, aged 77, in Göttingen in the Kingdom of Hanover. His brain was preserved and was studied by Rudolf Wagner who found highly developed convolutions present, perhaps accounting for his titanic intellect. His body is interred in the Albanifriedhof cemetery [304, p. 59] and, in 1995, the present author made a pilgrimage there and was only too glad to remove the soda pop cans littering this holy shrine of Mathematics! Source material for Gauss is available in [23, 42, 221, 287, 297].

Vignette 21 (Jakob Steiner: 1796-1863).

Jacob Steiner, considered by many to have been the greatest pure geometer since Apollonius of Perga, was born in the village of Utzenstorf just north of Bern, Switzerland [144]. At age 18, he left home to attend J. H. Pestalozzi's school at Yverdon where the educational methods were child-centered and based upon individual learner differences, sense perception and the student's self-activity. In 1818, he went to Heidelberg where he attended lectures on combinatorial analysis, differential and integral calculus and algebra, and earned his living giving private Mathematics lessons. In 1821, he traveled to Berlin where he first supported himself through private tutoring before obtaining a license to teach Mathematics at a Gymnasium. In 1834, he was appointed Extraordinary Professor of Mathematics at the University of Berlin, a post he held until his death. In Berlin, he made the acquaintance of Niels Abel, Carl Jacobi and August Crelle. Steiner became an early contributor to Crelle's Journal, which was the first journal entirely devoted to Mathematics. In 1826, the premier issue contained a long paper by Steiner (the first of 62 which were to appear in Crelle's Journal) that introduced the power of a point with respect to a circle, the points of similitude of circles and his principle of inversion. This paper also considers the problem: What is the maximum number of parts into which a space can be divided by n planes? (Answer: $\frac{n^3+5n+6}{6}$.) In 1832, Steiner published his first book, *Systematische Entwicklung der Abhängigkeit geometrischer Gestalten voneinander*, where he gives explicit expression to his approach to Mathematics: "The present work is an attempt to discover the organism through which the most varied spatial phenomena are linked with one another. There exist a limited number of very simple fundamental relationships that together constitute the schema by means of which the remaining theorems can be developed logically and without difficulty. Through the proper adoption of the few basic relations one becomes master of the entire field.". He was one of the greatest contributors to projective geometry (Steiner surface and Steiner Theorem). Then, there is the beautiful Poncelet-Steiner Theorem which shows that only one given circle and a straightedge are required

for Euclidean constructions. He also considered the problem: Of all ellipses that can be circumscribed about (inscribed in) a given triangle, which one has the smallest (largest) area? (Today, these ellipses are called the Steiner ellipses.) Steiner disliked algebra and analysis and advocated an exclusively synthetic approach to geometry. See Property 70 of Chapter 2 for his role in solving Malfatti's Problem and Application 20 of Chapter 3 for the application of Steiner triple-systems to error-correcting codes. He died in Bern, aged 67. Source material for Steiner is available in [287].

Vignette 22 (Joseph Bertrand: 1822-1900).

Joseph Bertrand was a child prodigy who was born in Paris, France and whose early career was guided by his uncle, the famed physicist and Mathematician Duhamel [144]. (He also had familial connections to Hermite, Picard and Appell.) He began attending lectures at l'École Polytechnique at age eleven and was awarded his doctorate at age 17 for a thesis in thermodynamics. At this same time, he published his first paper on the mathematical theory of electricity. In 1842, he was badly injured in a train crash and suffered a crushed nose and facial scars which he retained throughout his life. Early in his career, he published widely in mathematical physics, mathematical analysis and differential geometry. He taught at a number of institutions in France until becoming Professor of Analysis at Collège de France in 1862. In 1845, he conjectured that there is at least one prime between n and $2n - 2$ for every $n > 3$. This conjecture was proved by Chebyshev in 1850. In 1845, he made a major contribution to group theory involving subgroups of low index in the symmetric group. He was famed as the author of textbooks on arithmetic, algebra, calculus, thermodynamics and electricity. His book *Calcul des probabilités* (1888) contains Bertrand's Paradox which was described in Recreation 11 of Chapter 4. This treatise greatly influenced Poincaré's work on this same topic. Bertrand was elected a member of the Paris Academy of Sciences in 1856 and served as its Permanent Secretary from 1874 to the end of his life. He died in Paris, aged 78.

Vignette 23 (Georg Friedrich Bernhard Riemann: 1826-1866).

Bernhard Riemann was born in Breselenz, a village near Dannenberg in the Kingdom of Hanover in what is today the Federal Republic of Germany [203]. He exhibited exceptional mathematical skills, such as fantastic calculation abilities, from an early age. His teachers were amazed by his adept ability to perform complicated mathematical operations, in which he often outstripped his instructor's knowledge. While still a student at the Gymnasium in Lüneberg, he read and absorbed Legendre's 900 page book on number theory in six days. In 1846, he enrolled at the University of Göttingen and took courses from Gauss. In 1847 he moved to the University of Berlin to

study under Steiner, Jacobi, Dirichlet and Eisenstein. In 1849, he returned to Göttingen and submitted his thesis, supervised by Gauss, in 1851. This thesis applied topological methods to complex function theory and introduced Riemann surfaces to study the geometric properties of analytic functions, conformal mappings and the connectivity of surfaces. (A fundamental theorem on Riemann surfaces appears in Property 41 of Chapter 2.) In order to become a Lecturer, he had to work on his Habilitation. In addition to another thesis (on trigonometric series including a study of Riemann integrability), this required a public lecture which Gauss chose to be on geometry. The resulting *On the hypotheses that lie at the foundations of geometry* of 1854 is considered a classic of Mathematics. In it, he gave the definition of n -dimensional Riemannian space and introduced the Riemannian curvature tensor. For the case of a surface, this reduces to a scalar, the constant non-zero cases corresponding to the known non-Euclidean geometries. He showed that, in four dimensions, a collection of ten numbers at each point describe the properties of a manifold, i.e. a Riemannian metric, no matter how distorted. This provided the mathematical framework for Einstein's General Theory of Relativity sixty years later. This allowed him to begin lecturing at Göttingen, but he was not appointed Professor until 1857. In 1857, he published another of his masterpieces, *Theory of abelian functions* which further developed the idea of Riemann surfaces and their topological properties. In 1859, he succeeded Dirichlet as Chair of Mathematics at Göttingen and was elected to the Berlin Academy of Sciences. A newly elected member was expected to report on their most recent research and Riemann sent them *On the number of primes less than a given magnitude*. This great masterpiece, his only paper on number theory, introduced the Riemann zeta function and presented a number of conjectures concerning it, most notably the Riemann Hypothesis, the greatest unsolved problem in Mathematics [76] (Hilbert's Eighth Problem [332] and one of the \$1M Millenium Prize Problems [78]) ! It conjectures that, except for a few trivial exceptions, the roots of the zeta function all have a real part of $1/2$ in the complex plane. The Riemann Hypothesis implies results about the distribution of prime numbers that are in some ways as good as possible. His work on monodromy and the hypergeometric function in the complex domain established a basic way of working with functions by consideration of only their singularities. He died from tuberculosis, aged 39, in Salasca, Italy, where he was seeking the health benefits of the warmer climate. Source material for Riemann is available in [23, 42, 287].

Vignette 24 (James Clerk Maxwell: 1831-1879).

James Clerk Maxwell, physicist and Mathematician, was born in Edinburgh, Scotland [43, 215, 307]. He attended the prestigious Edinburgh Academy and, at age 14, wrote a paper on ovals where he generalized the definition of an

ellipse by defining the locus of a point where the sum of m times the distance from one fixed point plus n times the distance from a second fixed point is constant. ($m = n = 1$ corresponds to an ellipse.) He also defined curves where there were more than two foci. This first paper, *On the description of oval curves, and those having a plurality of foci*, was read to the Royal Society of Edinburgh in 1846. At age 16, he entered the University of Edinburgh and, although he could have attended Cambridge after his first term, he instead completed the full course of undergraduate studies at Edinburgh. At age 18, he contributed two papers to the *Transactions of the Royal Society of Edinburgh*. In 1850, he moved to Cambridge University, first to Peterhouse and then to Trinity where he felt his chances for a fellowship were greater. He was elected to the secret Society of Apostles, was Second Wrangler and tied for Smith's Prizeman. He obtained his fellowship and graduated with a degree in Mathematics in 1854. Immediately after taking his degree, he read to the Cambridge Philosophical Society the purely mathematical memoir *On the transformation of surfaces by bending*. In 1855, he presented *Experiments on colour* to the Royal Society of Edinburgh where he laid out the principles of colour combination based upon his observations of colored spinning tops (Maxwell discs). (Application 14 concerns the related Maxwell Color Triangle.) In 1855 and 1856, he read his two part paper *On Faraday's lines of force* to the Cambridge Philosophical Society where he showed that a few simple mathematical equations could express the behavior of electric and magnetic fields and their interaction. In 1856, Maxwell took up an appointment at Marischal College in Aberdeen. He spent the next two years working on the nature of Saturn's rings and, in 1859, he was awarded the Adams Prize of St. John's College, Cambridge for his paper *On the stability of Saturn's rings* where he showed that stability could only be achieved if the rings consisted of numerous small solid particles, an explanation finally confirmed by the Voyager spacecrafts in the 1980's! In 1860, he was appointed to the vacant chair of Natural Philosophy at King's College in London. He performed his most important experimental work during the six years that he spent there. He was awarded the Royal Society's Rumford medal in 1860 for his work on color which included the world's first color photograph, and was elected to the Society in 1861. He also developed his ideas on the viscosity of gases (Maxwell-Boltzmann kinetic theory of gases), and proposed the basics of dimensional analysis. This time is especially known for the advances he made in electromagnetism: electromagnetic induction, displacement current and the identification of light as an electromagnetic phenomenon. In 1865, he left King's College and returned to his Scottish estate of Glenlair until 1871 when he became the first Cavendish Professor of Physics at Cambridge. He designed the Cavendish laboratory and helped set it up. The four partial differential equations now known as Maxwell's equations first appeared in fully developed form in *A Treatise on*

Electricity and Magnetism (1873) although most of this work was done at Glenlair. It took until 1886 for Heinrich Hertz to produce the electromagnetic waves mathematically predicted by Maxwell's equations. Maxwell's legacy to us also includes the Maxwell distribution, Maxwell materials, Maxwell's theorem, the generalized Maxwell model and Maxwell's demon. He died of abdominal cancer at Cambridge, aged 48.

Vignette 25 (Charles Lutwidge Dodgson/Lewis Carroll:1832-1898).

C. L. Dodgson, a.k.a. Lewis Carroll, was born in Daresbury, Cheshire, England [52]. He matriculated at Christ Church, Oxford, graduating in 1854 and becoming Master of Arts there three years later. In 1852, while still an undergraduate, he won a Fellowship (allowing him to live in Christ Church College provided that he took Holy Orders and remained unmarried, both of which he did) and, in 1855, he was appointed Lecturer in Mathematics at his alma mater, where he stayed in various capacities until his death. His mathematical contributions included *Elementary Treatise on Determinants* (1867), *A Discussion of the Various Procedures in Conducting Elections* (1873), *Euclid and His Modern Rivals* (1879), *The Game of Logic* (1887), *Curiosa Mathematica* (1888/1893) and *Symbolic Logic* (1896). Despite these many and varied publications, he is best remembered for his children's stories *Alice's Adventures in Wonderland* (1865) and *Through the Looking Glass* (1872). Incidentally, Martin Gardner's most commercially successful books were his annotations of these children's classics. Even more interesting is that he was asked to undertake this publication venture only after the publishers could not get their first choice - Bertrand Russell! Dodgson/Carroll's predilection for paper folding was alluded to in Recreation 28. He died suddenly from what began as a minor cold in Guildford, Surrey, England, aged 65.

Vignette 26 (Hermann Amandus Schwarz: 1843-1921).

Hermann Schwarz was born in Hermsdorf, Silesia (now part of Poland) [144]. Initially, he studied chemistry at the Technical University of Berlin but switched to Mathematics, receiving his doctorate in 1864 for a thesis in algebraic geometry written under Weierstrass and examined by Kummer (his eventual father-in-law). He then taught at University of Halle and ETH-Zurich until accepting the Chair of Mathematics at Göttingen in 1875. In 1892, he returned to University of Berlin as Professor of Mathematics. His greatest strength lay in his geometric intuition as is evidenced by his first publication, an elementary proof of the chief theorem of axonometry (a method for mapping three-dimensional images onto the plane). He made important contributions to conformal mappings and minimal surfaces. His legacy to Mathematics is vast: Schwarz alternating method, Schwarzian derivative, Schwarz' lemma, Schwarz minimal surface, Schwarz-Christoffel formula, Cauchy-Schwarz inequality and

Schwarz reflection principle. The latter has previously been described in the context of Fagnano's Problem (Property 53) and Triangular Billiards (Recreation 20). He died in Berlin, aged 78. Source material for Schwarz is available in [23].

Vignette 27 (Jules Henri Poincaré: 1854-1912).

Henri Poincaré, described by many as The Last Universalist in Mathematics, was born into an upper middle class family in Nancy, France [67]. He was not the only distinguished member of his family. His cousin, Raymond Poincaré, was several times Prime Minister of France and President of the French Republic during World War I. In 1862, Henri entered the Lycée in Nancy (now renamed after him) and spent eleven years there as one of the top students in every subject. He won first prizes in the *concours général*, a competition between the top students from all across France. In 1873, he entered l'École Polytechnique, graduating in 1875. After graduation, he continued his studies at l'École des Mines after which he spent a short time working as a mining engineer while completing his doctoral work. In 1879, he received his doctorate under Charles Hermite at the University of Paris with a thesis on differential equations where he introduced the qualitative geometric theory which was to become so influential. He then was appointed to teach mathematical analysis at the University of Caen. In 1881, he became a Professor at the University of Paris and also at l'École Polytechnique, holding both posts for the rest of his life. The breadth and depth of his mathematical contributions is truly staggering. He won a mathematical competition based on his work on the three-body problem which used invariant integrals, introduced homoclinic points and gave the first mathematical description of chaotic motion. He also made fundamental contributions to number theory, automorphic functions and the theory of analytic functions of several complex variables. His work in algebraic topology was especially noteworthy where he created homotopy theory and introduced the notion of the fundamental group as well as formulated the celebrated Poincaré Conjecture which has only recently been settled in the affirmative by Grigory Perelman [141]. In Applied Mathematics, he made advances in fluid mechanics, optics, electricity, telegraphy, capillarity, elasticity, thermodynamics, potential theory, quantum theory, theory of relativity and celestial mechanics, the latter culminating in his masterpiece *Les Méthodes nouvelles de la mécanique céleste* in three volumes published between 1892 and 1899. See Property 84 of Chapter 2 for a description of the Poincaré disk model of the hyperbolic plane. His name has been enshrined in the Poincaré-Bendixson Theorem, the Poincaré Group, the Poincaré-Linstedt Method, the Poincaré Inequality, the Poincaré Metric and the Poincaré Map, to mention but a few. Poincaré's popular works included *Science and Hypothesis* (1901), *The Value of Science* (1905) and *Science and Method* (1908). He was the only

member of the French Academy of Sciences to be elected to every one of its five sections and he served as its President. In addition, he received many medals and honors. He died from complications following prostate surgery in Paris, France, aged 58. Source material for Poincaré is available in [23, 42].

Vignette 28 (Percy Alexander MacMahon: 1854-1929).

Percy MacMahon was born into a military family in Sliema, Malta [144]. In 1871, he entered the Royal Military Academy at Woolwich and studied under the renowned teacher of physics and Mathematics, Alfred George Greenhill. He was posted to India in 1873 until he was sent home to England in 1878 to recover his health. He was appointed Instructor of Mathematics at the Royal Military Academy in 1882 and held that post until he became Assistant Inspector at the Arsenal in 1888. In 1891, he took up a new post as Military Instructor in Electricity at the Royal Artillery College, Woolwich where he stayed until his retirement from the Army in 1898. He worked on invariants of binary quadratic forms and his interest in symmetric functions led him to study partitions of integers and Latin squares. In 1915/1916, he published his two volume *Combinatory Analysis* which was the first major book in enumerative combinatorics and is now considered a classic. The shorter *Introduction to Combinatory Analysis* was published in 1920. He also did pioneering work in Recreational Mathematics and patented several puzzles. His *New Mathematical Pastimes* (1921) contains the 24 color triangles introduced in Recreation 17. He was a Fellow of the Royal Society and served as President of the London Mathematical Society, Section A of the British Association and the Royal Astronomical Society. He was also the recipient of the Royal Medal, the Sylvester Medal and the Morgan Medal. He died in Bognor Regis, England, aged 75.

Vignette 29 (Frank Morley: 1860-1937).

Frank Morley was born into a Quaker family in Woodbridge, Suffolk, England [230, 330]. He studied with Sir George Airy at King's College, Cambridge, earning his B.A. in 1884. He then took a job as a school master, teaching Mathematics at Bath College until 1887. At that time he moved to Haverford College in Pennsylvania where he taught until 1900, when he became Chairman of the Mathematics Department at the Johns Hopkins University in Baltimore, Maryland. He spent the remainder of his career there, supervising 48 doctoral students. He published the book *A Treatise on the Theory of Functions* (1893) which was later revised as *Introduction to the Theory of Analytic Functions* (1898). He is best known for Morley's Theorem (see Property 11), which though discovered in 1899 was not published by him until 1929, but also loved posing mathematical problems. Over a period of 50 years, he published more than 60 such problems in *Educational Times*. Most were of a geometric nature: "Show that on a chessboard the number of visible squares is 204 while

the number of visible rectangles (including squares) is 1,296; and that, on a similar board with n squares on a side, the number of squares is the sum of the first n square numbers while the number of rectangles (including squares) is the sum of the first n cube numbers.” He was President of the American Mathematical Society and Editor of *American Journal of Mathematics* (where he finally published Morley’s Theorem). He was also an exceptional chess player, having defeated fellow Mathematician Emmanuel Lasker while the latter was still reigning World Champion! His three sons became Rhodes Scholars: Christopher became a famous novelist, Felix became Editor of *The Washington Post* and also President of Haverford College, and Frank became director of the publishing firm Faber and Faber but was also a Mathematician who published *Inversive Geometry* with his father in 1933. He died in Baltimore, aged 77.

Vignette 30 (Hermann Minkowski: 1864-1909).

Hermann Minkowski was born of German parents in Alexotas, a suburb of Kaunas, Lithuania which was then part of the Russian Empire [144]. The family returned to Germany and settled in Königsberg when he was eight years old. He received his higher education at the University of Königsberg where he became a lifelong friend of David Hilbert, his fellow student, and Adolf Hurwitz, his slightly older teacher. In 1883, while still a student at Königsberg, he was awarded the Mathematics Prize from the French Academy of Sciences for his manuscript on the theory of quadratic forms. His 1885 doctoral thesis at Königsberg was a continuation of this prize winning work. In 1887 he moved to the University of Bonn where he taught until 1894, then he returned to Königsberg for two years before becoming a colleague of Hurwitz at ETH, Zurich in 1896 where Einstein was his student. In 1896, he presented his *Geometry of Numbers*, a geometrical method for solving problems in number theory. In 1902, he joined the Mathematics Department of the University of Göttingen where he was reunited with Hilbert (who had arranged to have the chair created specifically for Minkowski) and he stayed there for the rest of his life. It is of great historical interest that it was in fact Minkowski who suggested to Hilbert the subject of his famous 1900 lecture in Paris on “the Hilbert Problems” [332]. In 1907, he realized that Einstein’s Special Theory of Relativity could best be understood in a non-Euclidean four-dimensional space now called *Minkowski spacetime* in which time and space are not separate entities but instead are intermingled. This space-time continuum provided the framework for all later mathematical work in this area, including Einstein’s General Theory of Relativity. In 1907, he published his *Diophantische Approximationen* which gave an elementary account of his work on the geometry of numbers and of its application to Diophantine approximation and algebraic numbers. His subsequent work on the geometry of numbers led him to investigate convex bodies and packing problems. His *Geometrie der Zahlen* was

published posthumously in 1910. M-matrices were named for him by Alexander Ostrowski. See Property 85 of Chapter 2 for a result on the Minkowski plane with a regular dodecagon as unit circle. He died suddenly of appendicitis in Göttingen, aged 44.

Vignette 31 (Helge von Koch: 1870-1924).

Helge von Koch was born into a family of Swedish nobility in Stockholm [144]. In 1892, he earned his doctorate under Gösta Mittag-Leffler at Stockholm University. Between the years 1893 and 1905, von Koch had several appointments as Assistant Professor of Mathematics until he was appointed to the Chair of Pure Mathematics at the Royal Institute of Technology in 1905, succeeding Ivar Bendixson. In 1911, he succeeded Mittag-Leffler as Professor of Mathematics at Stockholm University. Von Koch is known principally for his work in the theory of infinitely many linear equations and the study of the matrices derived from such infinite systems. He also did work in differential equations and the theory of numbers. One of his results was a 1901 theorem proving that the Riemann Hypothesis is equivalent to a stronger form of the Prime Number Theorem. He invented the Koch Snowflake (see Property 60) in his 1904 paper titled “On a continuous curve without tangents constructible from elementary geometry”. He died in Stockholm, aged 54.

Vignette 32 (Bertrand Russell: 1872-1970).

Bertrand Russell, 3rd Earl Russell, was born into a liberal family of the British aristocracy in Trelleck, Monmouthshire, Wales [51]. Due to the death of his parents, he was raised by his paternal grandparents. He was educated at home by a series of tutors before entering Trinity College, Cambridge as a scholar in 1890. There, he was elected to the Apostles where he met Alfred North Whitehead, then a mathematical lecturer at Cambridge. He earned his B.A. in 1893 and added a fellowship in 1895 for his thesis, *An Essay on the Foundations of Geometry*, which was published in 1897. Despite his previously noted criticism of *The Elements* (see opening paragraph of Chapter 1), it was his exposure to Euclid through his older brother Frank that set his life’s path of work in Mathematical Logic! Over a long and varied career, he made ground-breaking contributions to the foundations of Mathematics, the development of formal logic, as well as to analytic philosophy. His mathematical contributions include the discovery of Russell’s Paradox, the development of logicism (i.e. that Mathematics is reducible to formal logic), introduction of the theory of types and the refinement of the first-order predicate calculus. His other mathematical publications include *Principles of Mathematics* (1903), *Principia Mathematica* with Whitehead (1910, 1912, 1913) and *Introduction to Mathematical Philosophy* (1919). Although elected to the Royal Society in 1908, he was convicted and fined in 1916 for his anti-war activities and, as

a consequence, dismissed from Trinity. Two years later, he was convicted a second time and served six months in prison (where he wrote *Introduction to Mathematical Philosophy*). He did not return to Trinity until 1944. He was married four times and was notorious for his many affairs. Together with his second wife, he opened and ran an experimental school during the late 1920's and early 1930's. He became the third Earl Russell upon the death of his brother in 1931. While teaching in the United States in the late 1930's, he was offered a teaching appointment at City College of New York but the appointment was revoked following a large number of public protests and a judicial decision in 1940 which stated that he was morally unfit to teach youth. He was awarded the Order of Merit in 1949 and the Nobel Prize for Literature in 1950. In 1961, he was once again imprisoned in connection with anti-nuclear protests. He died in Penrhyndeudraeth, Merioneth, Wales, aged 97.

Vignette 33 (Henri Lebesgue: 1875-1941).

Henri Lebesgue was born in Beauvais, France and studied at l'École Normale Supérieure from 1894 to 1897, at which time he was awarded his teaching diploma in Mathematics [144]. He spent the next two years working in its library studying the works of René Baire on discontinuous functions. In 1898, he published his first paper on polynomial approximation where he introduced the Lebesgue constant. From 1899 to 1902, while teaching at the Lycée Centrale in Nancy, he developed the ideas that he presented in 1902 as his doctoral thesis, "Intégrale, longueur, aire", written under the supervision of Émile Borel at the Sorbonne. This thesis, considered to be one of the finest ever written by a Mathematician, introduced the pivotal concepts of Lebesgue measure and the Lebesgue integral. He then taught at Rennes (1902-1906) and Poitiers (1906-1910) before returning to the Sorbonne in 1910. In 1921, he was named Professor of Mathematics at the Collège de France, a position he held until his death. He is also remembered for the Riemann-Lebesgue lemma, Lebesgue's dominated convergence theorem, the Lebesgue-Stieltjes integral, the Lebesgue number and Lebesgue covering dimension in topology and the Lebesgue spine in potential theory. Property 56 of Chapter 2 contains a statement of the Blaschke-Lebesgue Theorem on curves of constant breadth. He was a member of the French Academy of Sciences, the Royal Society, the Royal Academy of Science and Letters of Belgium, the Academy of Bologna, the Accademia dei Lincei, the Royal Danish Academy of Sciences, the Romanian Academy and the Kraków Academy of Science and Letters. He was a recipient of the Prix Houlléville, the Prix Poncelet, the Prix Saintour and the Prix Petit d'Ormy. He died in Paris, France, aged 66.

Vignette 34 (Waclaw Sierpinski: 1882-1969).

Waclaw Sierpinski was born in Warsaw which at that time was part of the Russian Empire [144]. He enrolled in the Department of Mathematics and

Physics of the University of Warsaw. After his graduation in 1904, he worked as a school teacher in Warsaw before enrolling for graduate study at the Jagiellonian University in Kraków. He received his doctorate in 1906 under S. Zaremba and G. F. Voronoi and was appointed to the University of Lvov in 1908. He spent the years of World War I in Moscow working with Nikolai Luzin and returned to Lvov afterwards. Shortly thereafter, he accepted a post at the University of Warsaw where he spent the rest of his life. He made many outstanding contributions to set theory, number theory, theory of functions and topology. He published over 700 papers and 50 books. Three well-known fractals are named after him: the Sierpinski gasket (see Properties 60-62 and Application 24), the Sierpinski carpet and the Sierpinski curve. In number theory, a Sierpinski number is an odd natural number k such that all integers of the form $k \cdot 2^n + 1$ are composite for all natural numbers n . In 1960, he proved that there are infinitely many such numbers and the Sierpinski Problem, which is still open to this day, is to find the smallest one. He was intimately involved in the development of Mathematics in Poland, serving as Dean of the Faculty at the University of Warsaw and Chairman of the Polish Mathematical Society. He was a founder of the influential mathematical journal *Fundamenta Mathematica* and Editor-in-Chief of *Acta Arithmetica*. He was a member of the Bulgarian Academy of Sciences, the Accademia dei Lincei of Rome, the German Academy of Sciences, the U.S. National Academy of Sciences, the Paris Academy, the Royal Dutch Academy, the Romanian Academy and the Papal Academy of Sciences. In 1949 he was awarded Poland's Scientific Prize, First Class. He died in Warsaw, Poland, aged 87.

Vignette 35 (Wilhelm Blaschke: 1885-1962).

Wilhelm Blaschke was born in Graz, Austria, son of Professor of Descriptive Geometry Josef Blaschke [144]. Through his father's influence, he became a devotee of Steiner's concrete geometric approach to Mathematics. He studied architectural engineering for two years at the Technische Hochschule in Graz before going to the University of Vienna where he earned his doctorate under W. Wirtinger in 1908. He then visited different universities (Pisa, Göttingen, Bonn, Breifswald) to study with the leading geometers of the day. He next spent two years at Prague and two more years at Leipzig where he published *Kreis und Kugel* (1916) in which he investigated isoperimetric properties of convex figures in the style of Steiner. He then went to Königsberg for two years, briefly went to Tübingen, until finally being appointed to a chair at the University of Hamburg where he stayed (with frequent visits to universities around the world) for the remainder of his career. At Hamburg, he built an impressive department by hiring Hecke, Artin and Hasse. During World War II, he joined the Nazi Party, a decision that was to haunt him afterwards. He wrote an important book, *Vorlesungen über Differentialgeometrie* (1921-1929), which was a major three volume work. He also initiated the study of

topological differential geometry. See Property 27 for Blaschke's Theorem and Property 56 for the Blaschke-Lebesgue Theorem. He died in Hamburg, aged 76.

Vignette 36 (Richard Buckminster Fuller, Jr.: 1895-1983).

R. Buckminster Fuller was a famed architect, engineer and Mathematician born in Milton, Massachusetts [279]. Bucky, as he was known, holds the dubious distinction of having been expelled from Harvard - twice! Business disasters and the death of his four year old daughter brought him to the brink of suicide, but instead he shifted the course of his life to showing that technology could be beneficial to mankind if properly used. He developed a vectorial system of geometry, Synergetics [113], based upon the tetrahedron which provides maximum strength with minimum structure. He coined the term *Spaceship Earth* to emphasize his belief that we must work together globally as a crew if we are to survive. He is best known for his Dymaxion House, Dymaxion Car, Dymaxion Map (see Application 29) and geodesic dome (see Application 30). More than 200,000 of the latter have been built, the most famous being the United States Pavillion at the 1967 International Exhibition in Montreal. He has been immortalized in fullerenes which are molecules composed entirely of carbon in the form of a hollow sphere (*buckyball*), ellipsoid or tube. Specifically, C_{60} was the first to be discovered and is named buckminsterfullerene. He eventually became a Professor at Southern Illinois University until his retirement in 1975. He died in Los Angeles, California, aged 87.

Vignette 37 (Harold Scott MacDonald Coxeter: 1907-2003).

Donald Coxeter was born in London and educated at University of Cambridge [254]. He received his B.A. in 1929 and his doctorate in 1931 with the thesis *Some Contributions to the Theory of Regular Polytopes* written under the supervision of H. F. Baker. He then became a Fellow at Cambridge and spent two years as a research visitor at Princeton University. He then joined the faculty at University of Toronto in 1936 where he stayed for the remaining 67 years of his life. His research was focused on geometry where he made major contributions to the theory of polytopes (Coxeter polytopes), non-Euclidean geometry, group theory (Coxeter groups) and combinatorics. In 1938, he revised and updated Rouse Ball's *Mathematical Recreations and Essays*, first published in 1892 and still widely read today. He wrote a number of widely cited geometry books including *The Real Projective Plane* (1955), *Introduction to Geometry* (1961), *Regular Polytopes* (1963), *Non-Euclidean Geometry* (1965) and *Geometry Revisited* (1967). He also published 167 research articles. He was deeply interested in music and art: at one point he pondered becoming a composer and was a close friend of M. C. Escher. Another of his friends, R. Buckminster Fuller utilized his geometric ideas in his architecture. His role

in popularizing the mathematical work of the institutionalized artist George Odom has already been described in Chapter 1 and Property 74. He was a Fellow of the Royal Societies of London and Canada as well as a Companion of the Order of Canada, their highest honor. He died in Toronto, aged 96, and attributed his longevity to strict vegetarianism as well as an exercise regimen which included 50 daily push-ups.

Vignette 38 (Paul Erdős: 1913-1996).

Paul Erdős was born in Budapest, Hungary to Jewish parents both of whom were Mathematics teachers [175, 269]. His fascination with Mathematics developed early as is evidenced by his ability, at age three, to calculate how many seconds a person had lived. In 1934, at age 21, he was awarded a doctorate in Mathematics from Eötvös Loránd University for the thesis *Über die Primzahlen gewisser arithmetischer Reihen* written under the supervision of L. Fejér. Due to a rising tide of anti-Semitism, he immediately accepted the position of Guest Lecturer in Mathematics at Manchester University in England and, in 1938, he accepted a Fellowship at Princeton University. He then held a number of part-time and temporary positions which eventually led to an itinerant existence. To describe Erdős as peripatetic would be to risk the mother of all understatements. He spent most of his adult life living out of a single suitcase (sometimes traveling with his mother), had no checking account and rarely stayed consecutively in one place for more than a month. Friends and collaborators such as Ron Graham (see below) helped him with the mundane details of modern life. He was so eccentric that even his close friend, Stan Ulam, described him thusly: “His peculiarities are so numerous that it is impossible to describe them all.” He had his own idiosyncratic vocabulary including *The Book* which referred to an imaginary book in which God (whom he called the “Supreme Fascist”) had written down the most elegant proofs of mathematical theorems. He foreswore any sexual relations and regularly abused amphetamines. Mathematically, he was a problem solver and not a theory builder, frequently offering cash prizes for solutions to his favorite problems. He worked primarily on problems in combinatorics, graph theory, number theory, classical analysis, approximation theory, set theory and probability theory. His most famous result is the discovery, along with Atle Selberg, of an elementary proof of the Prime Number Theorem. See Properties 48 and 55 and Recreation 13 for a further discussion of his contributions. He published more papers (approximately 1475) than any other Mathematician in history with 511 coauthors. (Euler published more pages.) This prolific output led to the concept of the Erdős number which measures the collaborative distance between him and other Mathematicians. He was the recipient of the Cole and Wolf Prizes and was an Honorary Member of the London Mathematical Society. He died, aged 86, while attending, naturally enough, a Mathematics conference in Warsaw, Poland.

Vignette 39 (Solomon Wolf Golomb: 1932-).

Solomon W. Golomb, Mathematician and engineer, was born in Baltimore, Maryland [330]. He received his B.A. from Johns Hopkins in 1951 and his M.A. (1953) and Ph.D. (1957) in Mathematics from Harvard, where he wrote the thesis *Problems in the Distribution of Prime Numbers* under the supervision of D. V. Widder. He has worked at the Glenn L. Martin Company, where he became interested in communications theory and began working on shift register sequences, and the Jet Propulsion Laboratory at Caltech. In 1963, he joined the faculty of University of Southern California, where he remains today, with a joint appointment in the Departments of Electrical Engineering and Mathematics. His research has been specialized in combinatorial analysis, number theory, coding theory and communications. Today, millions of cordless and cellular phones rely upon his fundamental work on shift register sequences. However, he is best known as the inventor of Polyominoes (1953), the inspiration for the computer game *Tetris*. His other contributions to Recreational Mathematics include the theory of Rep-tiles (Recreation 15) and Hexiamonds (Recreation 16). He has been a regular columnist in *Scientific American*, *IEEE Information Society Newsletter* and *Johns Hopkins Magazine*. He has been the recipient of the NSA Research Medal, the Lomonosov and Kapitsa Medals of the Russian Academy of Sciences and the Richard W. Hamming Medal of the IEEE. He is also a Fellow of both IEEE and AAAS as well as a member of the National Academy of Engineering.

Vignette 40 (Ronald Lewis Graham: 1935-).

Ron Graham was born in Taft, California and spent his childhood moving back and forth between there and Georgia, eventually settling in Florida [230]. He then entered University of Chicago on a three year Ford Foundation scholarship at age 15 without graduating from high school. It is here that he learnt gymnastics and became proficient at juggling and the trampoline. Without graduating, he spent the next year at University of California at Berkeley studying electrical engineering before enlisting for four years in the Air Force. During these years of service, he earned a B.S. in Physics from University of Alaska. After his discharge, he returned to UC-Berkeley where he completed his Ph.D. under D.H. Lehmer in 1962 with the thesis *On Finite Sums of Rational Numbers*. He then joined the technical staff of Bell Telephone Laboratories where he worked on problems in Discrete Mathematics, specifically scheduling theory, computational geometry, Ramsey theory and quasi-randomness. (Here, he became Bell Labs and New Jersey ping-pong champion.) In 1963, he began his long collaboration with Paul Erdős which eventually led to 30 joint publications and his invention of the “Erdős number”. His contributions to partitioning an equilateral triangle have been described in Property 80 of Chapter 2. In 1977, he entered the *Guinness Book of Records* for what is now

known as Graham's number, the largest number ever used in a mathematical proof. He has also appeared in *Ripley's Believe It or Not* for not only being one of the world's foremost Mathematicians but also a highly skilled trampolinist and juggler. In fact, he has served as President of the American Mathematical Society, Mathematical Association of America and the International Jugglers' Association!. In 1999, he left his position as Director of Information Sciences at Bell Labs to accept a Chaired Professorship at University of California at San Diego which he still holds. He has been the recipient of the Pólya Prize, the Allendoerfer Award, the Lester R. Ford Award, the Euler Medal and the Steele Award. He is a member of the National Academy of Sciences, the American Academy of Arts and Sciences, the Hungarian Academy of Sciences, Fellow of the Association of Computing Machinery and the recipient of numerous honorary degrees. He has published approximately 320 papers (77 of which are coauthored with his wife, Fan Chung) and five books.

Vignette 41 (John Horton Conway: 1937-).

John Conway, perhaps the world's most untidy Mathematician, was born in Liverpool and educated at Gonville and Caius College, Cambridge [230]. After completing his B.A. in 1959, he commenced research in number theory under the guidance of Harold Davenport. During his studies at Cambridge, he developed his interest in games and spent hours playing backgammon in the common room. He earned his doctorate in 1964, was appointed Lecturer in Pure Mathematics at Cambridge and began working in mathematical logic. However, his first major result came in finite group theory when, in 1968, he unearthed a previously undiscovered finite simple group, of order 8,315,553,613,086,720,000 with many interesting subgroups, in his study of the Leech lattice of sphere packing in 24 dimensions! He became widely known outside of Mathematics proper with the appearance of Martin Gardner's October 1970 *Scientific American* article describing his *Game of Life*. It has been claimed that, since that time, more computer time has been devoted to it than to any other single activity. More importantly, it opened up the new mathematical field of cellular automata. Also in 1970, he was elected to a fellowship at Gonville and Caius and, three years later, he was promoted from Lecturer to Reader in Pure Mathematics and Mathematical Statistics at Cambridge. In his analysis of the game of Go, he discovered a new system of numbers, the surreal numbers. He has also analyzed many other puzzles and games such as the Soma cube and peg solitaire and invented many others such as Conway's Soldiers and the Angels and Devils Game. He is the inventor of the Doomsday algorithm for calculating the day of the week and, with S. B. Kochen, proved the Free Will Theorem of Quantum Mechanics whereby "If experimenters have free will then so do elementary particles." A better appreciation of the wide swath cut by his mathematical contributions can be gained by perusing Property 22

and Recreation 23. In 1983, he was appointed Professor of Mathematics at Cambridge and, in 1986, he left Cambridge to accept the John von Neumann Chair of Mathematics at Princeton which he currently holds. He has been the recipient of the Berwick Prize, the Pólya Prize, the Nemmers Prize, the Steele Prize and is a Fellow of the Royal Society. His many remarkable books include *Winning Ways for Your Mathematical Plays*, *The Book of Numbers* and *The Symmetries of Things*. The mathematical world anxiously awaits his forthcoming *The Triangle Book* which reportedly will be shaped like a triangle and will provide the definitive treatment of all things triangular!

Vignette 42 (Donald Ervin Knuth: 1938-).

Donald Knuth was born in Milwaukee, Wisconsin and was originally attracted more to Music than to Mathematics [230]. (He plays the organ, saxophone and tuba.) His first brush with notoriety came in high school when he entered a contest with the aim of finding how many words could be formed from “Ziegler’s Giant Bar”. He won top prize by forming 4500 words (without using the apostrophe)! He earned a scholarship to Case Institute of Technology to study physics but switched to Mathematics after one year. While at Case, he was hired to write compilers for various computers and wrote a computer program to evaluate the performance of the basketball team which he managed. This latter activity garnered him press coverage by both Newsweek and Walter Cronkite’s CBS Evening News. He earned his B.S. in 1960 and, in a unique gesture, Case awarded him an M.S. at the same time. That same year, he published his first two papers. He then moved on to graduate study at California Institute of Technology where he was awarded his Ph.D. in 1963 for his thesis *Finite Semifields and Projective Planes* written under the supervision of Marshall Hall, Jr. While still a doctoral candidate, Addison-Wesley approached him about writing a text on compilers which eventually grew to become the multi-volume mammoth *The Art of Computer Programming*. In 1963, he became an Assistant Professor of Mathematics at Caltech and was promoted to Associate Professor in 1966. It is during this period that he published his insightful analysis of triangular billiards that was described in detail in Recreation 20 of Chapter 4. In 1968, he was appointed Professor of Computer Science at Stanford University, where he is today Professor Emeritus. In 1974, he published the mathematical novelette *Surreal Numbers* describing Conway’s set theory construction of an alternative system of numbers. Starting in 1976, he took a ten year hiatus and invented *TeX*, a language for typesetting mathematics, and *METAFONT*, a computer system for alphabet design. These two contributions have literally revolutionized the field of scientific publication. He is also widely recognized as the Father of Analysis of Algorithms. He has been the recipient of the Grace Murray Hopper Award, the Alan M. Turing Award, the Lester R. Ford Award, the IEEE Computer

Pioneer Award, the National Medal of Science, the Steele Prize, the Franklin Medal, the Adelskold Medal, the John von Neumann Medal, the Kyoto Prize, the Harvey Prize and the Katayanagi Prize. He is a Fellow of the American Academy of Arts and Science and a member of the National Academy of Sciences, the National Academy of Engineering, Académie des Sciences, the Royal Society of London and the Russian Academy of Sciences, as well as an Honorary Member of the IEEE. In 1990, he gave up his e-mail address so that he might concentrate more fully on his work and, since 2006, he has waged a (thus far) successful battle against prostate cancer.

Vignette 43 (Samuel Loyd, Sr.: 1841-1911).

Sam Loyd has been described by Martin Gardner as “America’s greatest puzzlist and an authentic American genius” [119]. His most famous work is *Cyclopedia of Puzzles* (1914) [210] which was published posthumously by his son. The more mathematical puzzles from this magnum opus were selected and edited by Martin Gardner [211, 212]. He was born in Philadelphia and raised in Brooklyn, New York. Rather than attending college, he supported himself by composing and publishing chess problems. At age 16, he became problem editor of *Chess Monthly* and later wrote a weekly chess page for *Scientific American Supplement*. (Many of his contributions appeared under such monikers as W. King, A. Knight and W. K. Bishop.) Most of these columns were collected in his book *Chess Strategy* (1878). In 1987, he was inducted into the U.S. Chess Hall of Fame for his chess compositions. After 1870, the focus of his work shifted toward mathematical puzzles, some of which were published in newspapers and magazines while others were manufactured and marketed. His Greek Symbol Puzzle is considered in Recreation 1 of Chapter 4. He died at his home on Halsey Street in Brooklyn, aged 70.

Vignette 44 (Henry Ernest Dudeney: 1857-1930).

Henry Ernest Dudeney has been described by Martin Gardner as “England’s greatest inventor of puzzles; indeed, he may well have been the greatest puzzlist who ever lived” [120]. His most famous works are *The Canterbury Puzzles* (1907) [85], *Amusements in Mathematics* (1917) [86], *Modern Puzzles* (1926) and *Puzzles and Curious Problems* (1931). The last two were combined and edited by Martin Gardner [87]. He was born in the English village of Mayfield, East Sussex and, like Loyd, entered a life of puzzling through a fascination with chess problems. His lifelong involvement with puzzles (often published in newspapers and magazines under the pseudonym of “Sphinx”) was done against the backdrop of a career in the Civil Service. For twenty years, he wrote the successful column “Perplexities” in *The Strand* magazine (of Sherlock Holmes fame!). For a time, he engaged in an active correspondence with Loyd (they even collaborated on a series of articles without ever

meeting) but broke it off, accusing Loyd of plagiarism. His hobbies, other than puzzling, included billiards, bowling and, especially, croquet, and he was a skilled pianist and organist. A selection of his puzzles are considered in Recreations 2-5 of Chapter 4. He died at his home in Lewes, Sussex, aged 73.

Vignette 45 (Martin Gardner: 1914-2010).

For 25 years Martin Gardner wrote “Mathematical Games and Recreations”, a monthly column for *Scientific American* magazine. (An anthology of these columns is available in [137].) He was the author of more than 70 books, the vast majority of which deal with mathematical topics. He was born and grew up in Tulsa, Oklahoma. He earned a degree in philosophy from University of Chicago and also began graduate studies there. He served in the U.S. Navy during World War II as ship’s secretary aboard the destroyer escort USS Pope. For many years, he lived in Hastings-on-Hudson, New York (on Euclid Avenue!) and earned his living as a freelance writer, although in the early 1950’s he was editor of *Humpty Dumpty Magazine*. In 1979, he semi-retired and moved to Henderson, North Carolina. In 2002, he returned home to Norman, Oklahoma. Some of his more notable contributions to Recreational Mathematics are discussed in Property 22 of Chapter 2 and Recreation 20 of Chapter 4. Despite not being a “professional” mathematician, the American Mathematical Society awarded him the Steele Prize in 1987, in recognition of the generations of mathematicians inspired by his writings. The Mathematical Association of America has honored him for his contributions by holding a special session on Mathematics related to his work at its annual meeting in 1982 and by making him an Honorary Member of the Association. He was also an amateur magician thereby making him a bona fide Mathemagician! He died at a retirement home in Norman, aged 95.



Figure 6.2: Pythagoras

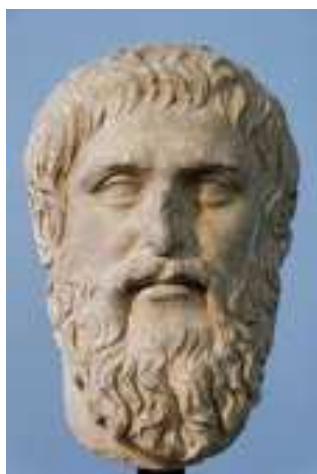

Figure 6.3: Plato



Figure 6.4: Euclid

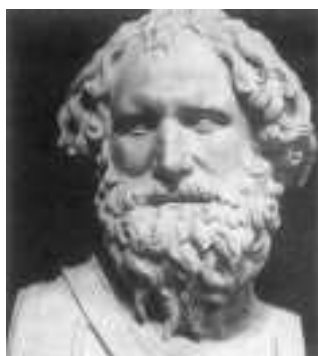

Figure 6.5: Archimedes



Figure 6.6: Apollonius



Figure 6.7: Pappus



Figure 6.8: Fibonacci



Figure 6.9: Da Vinci



Figure 6.10: Tartaglia



Figure 6.11: Kepler



Figure 6.12: Descartes



Figure 6.13: Fermat



Figure 6.14: Torricelli



Figure 6.15: Viviani



Figure 6.16: Pascal



Figure 6.17: Newton



Figure 6.18: Euler



Figure 6.19: Malfatti



Figure 6.20: Lagrange



Figure 6.21: Gauss



Figure 6.22: Steiner



Figure 6.23: Bertrand



Figure 6.24: Riemann



Figure 6.25: Maxwell



Figure 6.26: Dodgson



Figure 6.27: Schwarz



Figure 6.28: Poincaré



Figure 6.29: MacMahon



Figure 6.30: Morley



Figure 6.31: Minkowski



Figure 6.32: Von Koch



Figure 6.33: Russell



Figure 6.34: Lebesgue



Figure 6.35: Sierpinski



Figure 6.36: Blaschke



Figure 6.37: Fuller

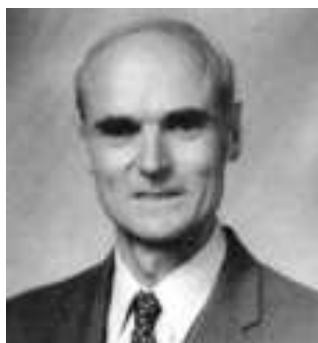

Figure 6.38: Coxeter



Figure 6.39: Erdős



Figure 6.40: Golomb



Figure 6.41: Graham



Figure 6.42: Conway



Figure 6.43: Knuth



Figure 6.44: Loyd

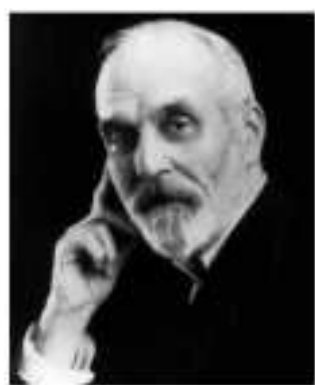

Figure 6.45: Dudeney

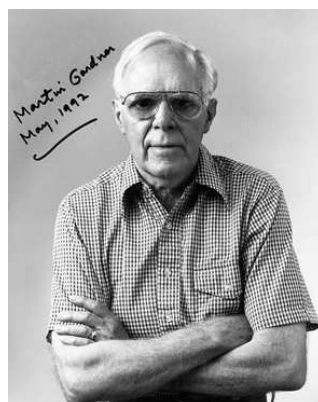

Figure 6.46: Gardner

Appendix A

Gallery of Equilateral Triangles

Equilateral triangles appear throughout the Natural and Man-made worlds. This appendix includes a pictorial panorama of such equilateral delicacies.

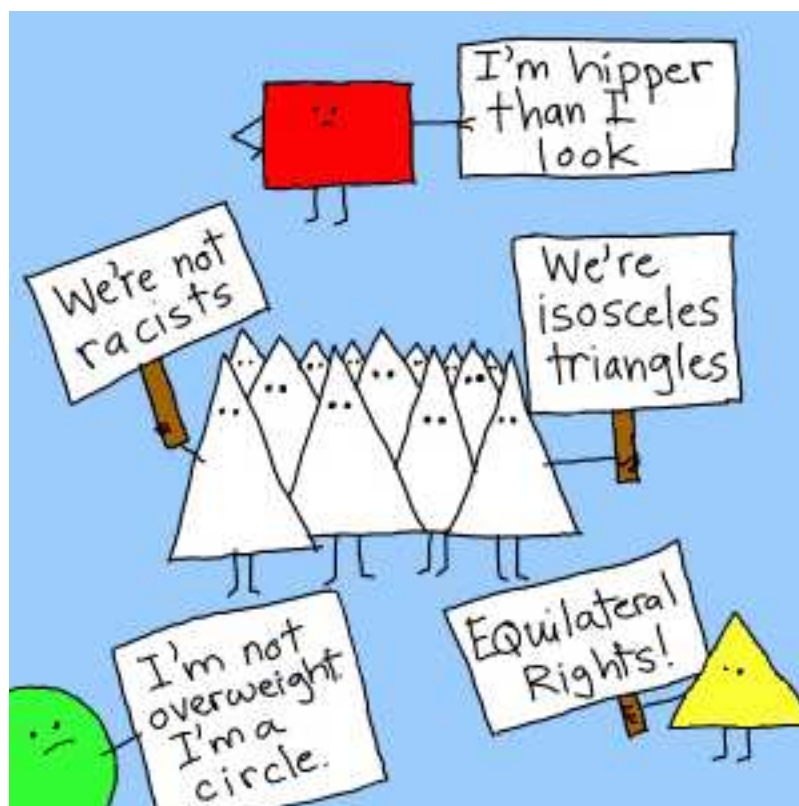

Figure A.1: Equilateral Triangular (ET) Humor



Figure A.2: ET Cat



Figure A.3: ET Ducks



Figure A.4: ET Geese



Figure A.5: ET Fighters



Figure A.6: ET Tulip



Figure A.7: ET Bombers



Figure A.8: ET Wing



Figure A.9: ET Moth



Figure A.10: ET UFO



Figure A.11: Winter ET

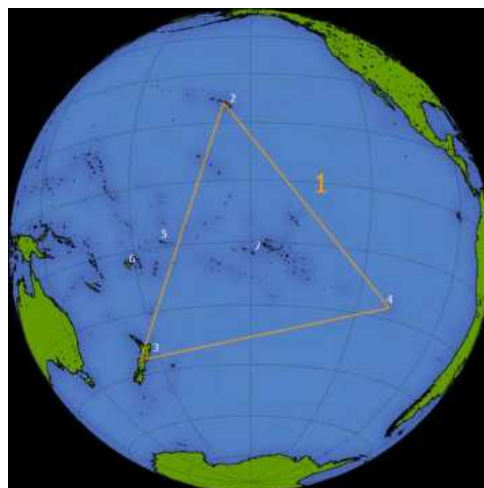

Figure A.12: Tahiti ET

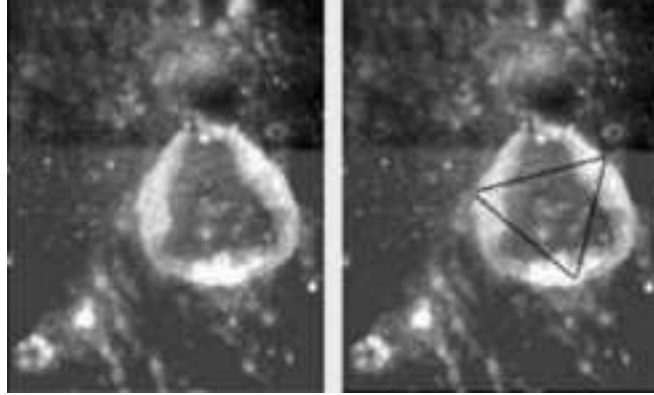

Figure A.13: ET Lunar Crater



Figure A.14: ET Rock Formation



Figure A.15: ET Stone



Figure A.16: ET Gem [21]



Figure A.17: ET Crystals [163]



Figure A.18: ET Bowling



Figure A.19: ET Pool Balls



Figure A.20: ET Die



Figure A.21: ET Game



Figure A.22: Musical ET



Figure A.23: ET Philately



Figure A.24: Sweet ETs



Figure A.25: ET Hat



Figure A.26: ET Flag (Philippines)



Figure A.27: Scary ETs



Figure A.28: ET Escher [268]



Figure A.29: ET Möbius Band [240]



Figure A.30: ET Shawl [18]



Figure A.31: ET Quilt [225]



Figure A.32: ET Playscape



Figure A.33: ET Dome



Figure A.34: ET Chair



Figure A.35: ET Danger



Figure A.36: ET Street Signs



Figure A.37: ET Fallout Shelter



Figure A.38: Impossible ET

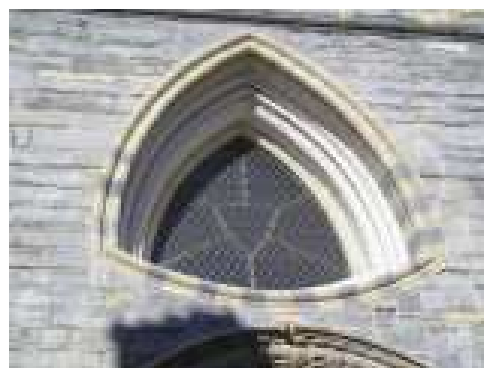

Figure A.39: ET Window



Figure A.40: Sacred ETs



Figure A.41: Secular ETs



Figure A.42: ET House



Figure A.43: ET Lodge [68]



Figure A.44: ET Tragedy (Triangle Waist Co., New York: March 25, 1911)

Bibliography

- [1] R. Abraham and J. E. Marsden, *Foundations of Mechanics*, Second Edition, AMS Chelsea, Providence, RI, 2008.
- [2] D. Acheson, *1089 and All That: A Journey into Mathematics*, Oxford University Press, Oxford, 2002.
- [3] A. D. Aczel, *Descartes' Secret Notebook*, Random House, New York, NY, 2005.
- [4] C. Adams, F. Morgan and J. M. Sullivan, "When Soap Bubbles Collide", *American Mathematical Monthly*, Vol. 114, No. 4 (2007), pp. 329-337.
- [5] G. A. Agoston, *Color Theory and Its Application in Art and Design*, Springer-Verlag, Berlin, 1987.
- [6] N. Altshiller-Court, *College Geometry: An Introduction to the Modern Geometry of the Triangle and the Circle*, Barnes & Noble, New York, NY, 1952.
- [7] T. Andreescu and Z. Feng, *Mathematical Olympiads: Problems and Solutions from Around the World 1998-1999*, Mathematical Association of America, Washington, DC, 2000.
- [8] T. Andreescu and Z. Feng, *Mathematical Olympiads: Problems and Solutions from Around the World 1999-2000*, Mathematical Association of America, Washington, DC, 2000.
- [9] T. Andreescu, Z. Feng, and G. Lee Jr., *Mathematical Olympiads: Problems and Solutions from Around the World 2000-2001*, Mathematical Association of America, Washington, DC, 2003.
- [10] W. Apel, *Harvard Dictionary of Music*, Second Edition, Revised and Enlarged, Belnap/Harvard University Press, Cambridge, MA, 1972.
- [11] R. A. Artino, A. M. Gaglione and N. Shell, *The Contest Problem Book IV: 1973-1982*, Mathematical Association of America, Washington, DC, 1982.

- [12] J. Aubrey, *Brief Lives and Other Selected Writings*, Scribners, New York, NY, 1949.
- [13] R. Avizienis, A. Freed, P. Kassakian, and D. Wessel, “A Compact 120 Independent Element Spherical Loudspeaker Array with Programmable Radiation Patterns”, *Audio Engineering Society 120th Convention*, Paris, France (2006), Paper No. 6783.
- [14] W. W. R. Ball, *Mathematical Recreations & Essays*, Eleventh Edition, Macmillan, New York, NY, 1944.
- [15] M. Barber, *The New Knighthood: A History of the Order of the Temple*, Cambridge University Press, Cambridge, 1994.
- [16] A. M. Baxter and R. Umble, “Periodic Orbits for Billiards on an Equilateral Triangle”, *American Mathematical Monthly*, Vol. 115, No. 6 (June-July 2008), pp. 479-491.
- [17] M. J. Beeson, “Triangles with Vertices on Lattice Points”, *American Mathematical Monthly*, Vol. 99, No. 3 (March 1992), pp. 243-252.
- [18] S.-M. Belcastro and C. Yackel, *Making Mathematics with Needlework*, A. K. Peters, Wellesly, MA, 2008.
- [19] E. T. Bell, *The Last Problem*, Simon and Schuster, New York, NY, 1961.
- [20] C. D. Bennett, B. Mellor, and P. D. Shanahan, “Drawing a Triangle on the Thurston Model of Hyperbolic Space”, *Mathematics Magazine*, Vol. 83, No. 2 (2010), pp. 83-99.
- [21] D. Bergamini, *Mathematics (Life Science Library)*, Time, New York, NY, 1963.
- [22] G. Berzsenyi and S. B. Maurer, *The Contest Problem Book V: 1983-1988*, Mathematical Association of America, Washington, DC, 1997.
- [23] G. Birkhoff, *A Source Book in Classical Analysis*, Harvard University Press, Cambridge, MA, 1973.
- [24] G. D. Birkhoff, *Dynamical Systems*, American Mathematical Society Colloquium Publications, Volume IX, Providence, RI, 1927.
- [25] M. Bishop, *Pascal: The Life of Genius*, Bell, London, 1937.
- [26] W. J. Blundon, “Inequalities Associated with the Triangle”, *Canadian Mathematical Bulletin*, Vol. 8 (1965), pp. 615-626.

- [27] N. N. Bogolyubov, G. K. Mikhailov and A. P. Yushkevich (Editors), *Euler and Modern Science*, Mathematical Association of America, Washington, DC, 2007.
- [28] A. Bogomolny, “Euler Line Cuts Off Equilateral Triangle” from *Interactive Mathematics Miscellany and Puzzles*, <http://www.cut-the-knot.org/Curriculum/Geometry/Euler60.shtml>, Accessed 02 April 2010.
- [29] L. Bosman, *Mysteries of the Triangle*, Kessinger, Whitefish, MT, 2003.
- [30] A. Bowes, “The Equilateral Triangle in Gothic Architecture”, *Ars Quatuor Coronatorum*, Vol. XIX (1906), pp. 165-170.
- [31] C. B. Boyer, *A History of Mathematics*, Wiley, New York, NY, 1968.
- [32] R. E. Bradley, L. A. D’Antonio and C. E. Sandifer (Editors), *Euler at 300*, Mathematical Association of America, Washington, DC, 2007.
- [33] D. A. Brannan, M. F. Esplen and J. J. Gray, *Geometry*, Cambridge University Press, Cambridge, 1999.
- [34] C. B. Breed and G. L. Hosmer, *The Principles and Practice of Surveying*, Fourth Edition, Wiley, London, 1917.
- [35] E. Buchman, “The Impossibility of Tiling a Convex Region with Unequal Equilateral Triangles”, *American Mathematical Monthly*, Vol. 88, No. 10, (December 1981), pp. 748-753.
- [36] W. K. Bühler, *Gauss: A Biographical Study*, Springer-Verlag, New York, 1981.
- [37] H. Burgiel, D. S. Franzblau and K. R. Gutschera, “The Mystery of the Linked Triangles”, *Mathematics Magazine*, Vol. 69, No. 2 (April 1996), pp. 94-102.
- [38] R. Caddeo, S. Montaldo and P. Piu, “The Möbius Strip and Viviani’s Windows”, *Mathematical Intelligencer*, Vol. 23, No. 3 (2001), pp. 36-40.
- [39] J. H. Cadwell, *Topics in Recreational Mathematics*, Cambridge University Press, Cambridge, 1966.
- [40] E. Cailliet, *Pascal: The Emergence of Genius*, Harper Torchbook, New York, NY, 1961.
- [41] F. Cajori, *History of Mathematics*, Chelsea, New York, NY, 1985.

- [42] R. Calinger, *Classics of Mathematics*, Prentice Hall, Upper Saddle River, NJ, 1982.
- [43] L. Campbell and W. Garnett, *The Life of James Clerk Maxwell*, Macmillan, London, 1884.
- [44] F. Capra, *The Science of Leonardo*, Doubleday, New York, NY, 2007.
- [45] E. P. Carter, C. P. Richter and C. H. Greene, “A Graphic Application of the Principle of the Equilateral Triangle for Determining the Direction of the Electrical Axis of the Heart in the Human Electrocardiogram”, *Bulletin of the Johns Hopkins Hospital*, Vol. XXX, No. 340 (June 1919), pp. 162-167.
- [46] J. Casey, *A Treatise on the Analytical Geometry of the Point, Line, Circle, and Conic Sections*, Dublin University Press, Dublin, 1893.
- [47] G. Chang and T. W. Sederberg, *Over and Over Again*, Mathematical Association of America, Washington, DC, 1997.
- [48] Z. Chen and T. Liang, “The Converse of Viviani’s Theorem”, *College Mathematics Journal*, Vol. 37, No. 5 (2006), pp. 390-391.
- [49] P. Christian, *The History and Practice of Magic*, Citadel Press, Secaucus, NJ, 1963.
- [50] T. Churton, *The Invisible History of the Rosicrucians: The World’s Most Mysterious Secret Society*, Inner Traditions, Rochester, VT, 2009.
- [51] R. W. Clark, *The Life of Bertrand Russell*, Knopf, New York, NY, 1975.
- [52] M. N. Cohen, *Lewis Carroll: A Biography*, Vintage, New York, NY, 1995.
- [53] G. M. Cole, “The Beginnings of Satellite Geodesy”, *Professional Surveyor Magazine*, Vol. 30, No. 1 (January 2010), *History Corner*.
- [54] S. Colman, *Harmonic Proportion and Form in Nature, Art and Architecture*, Dover, Mineola, NY, 2003.
- [55] J. H. Conway and R. K. Guy, *The Book of Numbers*, Copernicus, New York, NY, 1996.
- [56] J. L. Coolidge, *The Mathematics of Great Amateurs*, Dover, New York, NY, 1963.
- [57] R. Courant and H. Robbins, *What Is Mathematics?*, Oxford University Press, New York, NY, 1941.

- [58] H. S. M. Coxeter, *Introduction to Geometry*, Second Edition, Wiley, New York, NY, 1969.
- [59] H. S. M. Coxeter, "Virus Macromolecules and Geodesic Domes", in *A Spectrum of Mathematics (Essays Presented to H. G. Forder)*, J. C. Butcher (Editor), Auckland University Press, Auckland, 1971, pp. 98-107.
- [60] H. S. M. Coxeter, *Regular Polytopes*, Third Edition, Dover, New York, NY, 1973.
- [61] H. S. M. Coxeter, "Symmetrical Combinations of Three or Four Hollow Triangles", *Mathematical Intelligencer*, Vol. 16, No. 3 (1994), pp. 25-30.
- [62] H. S. M. Coxeter and S. L. Greitzer, *Geometry Revisited*, Mathematical Association of America, Washington, DC, 1967.
- [63] T. Crilly, *50 Mathematical Ideas You Really Need to Know*, Quercus, London, 2007.
- [64] H. T. Croft, K. J. Falconer and R. K. Guy, *Unsolved Problems in Geometry*, Springer-Verlag, New York, NY, 1991.
- [65] J. F. Crow and M. Kimura, *An Introduction to Population Genetics Theory*, Blackburn, Caldwell, NJ, 1970.
- [66] H. M. Cundy and A. P. Rollett, *Mathematical Models*, Oxford University Press, Oxford, 1951.
- [67] T. Dantzig, *Henri Poincaré*, Scribners, New York, NY, 1954.
- [68] D. Darling, *The Universal Book of Mathematics: From Abracadabra to Zeno's Paradoxes*, Castle, Edison, NJ, 2007.
- [69] P. J. Davis, *The Schwarz Function and Its Applications*, Mathematical Association of America, Washington, DC, 1974.
- [70] P. J. Davis, "The Rise, Fall, and Possible Transfiguration of Triangle Geometry: A Mini-History", *American Mathematical Monthly*, Vol. 102, No. 3 (1995), pp. 204-214.
- [71] P. J. Davis, *Mathematical Encounters of the Second Kind*, Birkhäuser, Boston, MA, 1997.
- [72] R. O. E. Davis and H. H. Bennett, "Grouping of Soils on the Basis of Mechanical Analysis", *USDA Departmental Circulation*, No. 419 (1927).
- [73] D. Dekov, "Equilateral Triangles", *Journal of Computer-Generated Euclidean Geometry*, Vol. 2007, No. 41 (December 2007), pp. 1-9.

- [74] J.-P. Delahaye, *Le Fascinant Nombre π* , Belin·Pour La Science, Paris, 1997.
- [75] E. D. Demaine, M. L. Demaine, J. Iacono and S. Langerman, “Wrapping Spheres with Flat Paper”, *Computational Geometry: Theory and Applications*, Vol. 42, No. 8 (2009), pp. 748-757.
- [76] J. Derbyshire, *Prime Obsession*, Joseph Henry Press, Washington, DC, 2003.
- [77] R. Descartes, *La Géométrie*, Dover, New York, NY, 1954.
- [78] K. Devlin, *The Millenium Problems*, Basic Books, New York, NY, 2002.
- [79] W. R. Dickinson and C. A. Suczek, “Plate Tectonics and Sandstone Compositions”, *American Association of Petroleum Geologists Bulletin*, Vol. 63, No. 12 (December 1979), pp. 2164-2182.
- [80] E. J. Dijksterhuis, *Archimedes*, Princeton University Press, Princeton, NJ, 1987.
- [81] C. W. Dodge, *Euclidean Geometry and Transformations*, Dover, Mineola, NY, 2004.
- [82] C. L. Dodgson, *Curiosa Mathematica, Part 2: Pillow Problems*, Third Edition, Macmillan, London, 1894.
- [83] E. P. Doolan, “A Sacred Geometry of the Equilateral Triangle”, *International Journal of Mathematical Education in Science and Technology*, Vol. 39, No. 5 (2008), pp. 601-629.
- [84] H. Dörrie, *100 Great Problems of Elementary Mathematics: Their History and Solution*, Dover, New York, NY, 1965.
- [85] H. E. Dudeney, *The Canterbury Puzzles*, Dover, Mineola, NY, 1958.
- [86] H. E. Dudeney, *Amusements in Mathematics*, Dover, Mineola, NY, 1958.
- [87] H. E. Dudeney, *536 Puzzles & Curious Problems*, M. Gardner (Editor), Scribner, New York, NY, 1967.
- [88] C. Dumontier, *Clinical Examination of the Elbow*, http://www.maitrise-orthop.com/corpusmaitri/orthopaedic/mo77_dumontier/index_us.shtml.
- [89] W. Dunham (Editor), *The Genius of Euler: Reflections on his Life and Work*, Mathematical Association of America, Washington, DC, 2007.

- [90] G. W. Dunnington, *Gauss: Titan of Science*, The Mathematical Association of America, Washington, DC, 2004.
- [91] D. S. Dye, *Chinese Lattice Designs*, Harvard-Yenching Institute Monograph Series 5-6, Dover, Mineola, NY, 1974.
- [92] A. W. F. Edwards, *Foundations of Mathematical Genetics*, Second Edition, Cambridge University Press, Cambridge, 2000.
- [93] A. W. F. Edwards, *Pascal's Arithmetical Triangle: The Story of a Mathematical Idea*, The Johns Hopkins University Press, Baltimore, MD, 2002.
- [94] H. G. Eggleston, *Problems in Euclidean Space: Application of Convexity*, Dover, Mineola, NY, 2007.
- [95] D. Erdély, *Spidron System*, <http://edan.szhaz.org/SpidroNew/>.
- [96] P. Erdős and J. Surányi, *Topics in the Theory of Numbers*, Springer, New York, NY, 2003.
- [97] H. Eves, *A Survey of Geometry*, Revised Edition, Allyn and Bacon, Boston, MA, 1972.
- [98] H. Eves, *Great Moments in Mathematics (Before 1650)*, Mathematical Association of America, Washington, DC, 1983.
- [99] J. D. Faires and D. Wells, *The Contest Problem Book VIII (AMC 10): 2000-2007*, Mathematical Association of America, Washington, DC, 2008.
- [100] K. Falconer, *Fractal Geometry: Mathematical Foundations and Applications*, Wiley, Chichester, 1990.
- [101] H. Fantel, "Major de Seversky's Ion-Propelled Aircraft", *Popular Mechanics*, Vol. 122, No. 2 (August 1964), pp. 58-61, p. 194, p. 196.
- [102] E. A. Fellmann, *Leonhard Euler*, Birkhäuser, Basel, 2007.
- [103] Z. Feng, M. M. Wood, and C. Rousseau, *USA and International Mathematical Olympiads 2005*, Mathematical Association of America, Washington, DC, 2006.
- [104] Z. Feng, and Y. Zhao, *USA and International Mathematical Olympiads 2006-2007*, Mathematical Association of America, Washington, DC, 2008.
- [105] K. Ferguson, *Tycho & Kepler*, Walker, New York, NY, 2002.

- [106] J. A. Flint, “A Biomimetic Antenna in the Shape of a Bat’s Ear”, *IEEE Antennas and Wireless Propagation Letters*, Vol. 5, Issue 1 (Dec. 2006), pp. 145-147.
- [107] D. H. Fowler, *The Mathematics of Plato’s Academy: A New Reconstruction*, Oxford University Press, Oxford, 1987.
- [108] J. B. Fraleigh, *A First Course in Abstract Algebra*, Addison-Wesley, Reading, MA, 1967.
- [109] G. N. Frederickson, *Dissections: Plane & Fancy*, Cambridge University Press, Cambridge, 1997.
- [110] E. Friedman, *Erich’s Packing Center*, <http://www2.stetson.edu/~efriedma/packing.html>, 2010.
- [111] H. Fukagawa and D. Pedoe, *Japanese Temple Geometry Problems*, Charles Babbage Research Center, Winnipeg, 1989.
- [112] H. Fukagawa and T. Rothman, *Sacred Mathematics: Japanese Temple Geometry*, Princeton University Press, Princeton, NJ, 2008.
- [113] R. B. Fuller, *Synergetics: Explorations in the Geometry of Thinking*, Macmillan, New York, NY, 1975.
- [114] Z. Füredi and J. E. Wetzel, “The Smallest Convex Cover for Triangles of Perimeter Two”, *Geometriae Dedicata*, Vol. 81, No. 3 (July 2000), pp. 285-293.
- [115] D. Furlong, *The Keys to the Temple*, Piatkus, London, 1997.
- [116] W. Gallatly, *The Modern Geometry of the Triangle*, Second Edition, Hodgson, London, 1929.
- [117] A. F. Garcia Marin, G. Heinzel and K. Danzmann, “Interferometry for LISA and LISA Pathfinder”, *Journal of Physics: Conference Series*, Vol. 66, No. 012052 (2007), pp. 1-5.
- [118] M. Gardner, “Mathematical Games: How to solve puzzles by graphing the rebounds of a bouncing ball”, *Scientific American*, Vol. 209, No. 3 (September 1963), pp. 248-266.
- [119] M. Gardner, *Hexagons, Probability Paradoxes, and the Tower of Hanoi*, Cambridge University Press, New York, NY, 2008.
- [120] M. Gardner, *Origami, Eleusis, and the Soma Cube*, Cambridge University Press, New York, NY, 2008.

- [121] M. Gardner, *The Scientific American Book of Mathematical Puzzles & Diversions*, Dover, Mineola, NY, 1959.
- [122] M. Gardner, *The 2nd Scientific American Book of Mathematical Puzzles & Diversions*, Dover, Mineola, NY, 1961.
- [123] M. Gardner, *New Mathematical Diversions from Scientific American*, Simon and Schuster, New York, NY, 1966.
- [124] M. Gardner, *The Incredible Dr. Matrix*, Scribner's, New York, NY, 1967.
- [125] M. Gardner, *The Unexpected Hanging and Other Mathematical Diversions*, Simon and Schuster, New York, NY, 1969.
- [126] M. Gardner, *Sixth Book of Mathematical Games from Scientific American*, W. H. Freeman, San Francisco, CA, 1971.
- [127] M. Gardner, *Mathematical Carnival*, Random House, New York, NY, 1975.
- [128] M. Gardner, *Mathematical Magic Show*, Knopf, New York, NY, 1977.
- [129] M. Gardner, *Mathematical Circus*, Knopf, New York, NY, 1979.
- [130] M. Gardner, *Wheels, Life and Other Mathematical Amusements*, Freeman, New York, NY, 1983.
- [131] M. Gardner, *Knotted Doughnuts and Other Mathematical Entertainments*, Freeman, New York, NY, 1986.
- [132] M. Gardner, *Time Travel and Other Mathematical Bewilderments*, Freeman, New York, NY, 1988.
- [133] M. Gardner, *Penrose Tiles to Trapdoor Ciphers ...and The Return of Dr. Matrix*, Freeman, New York, NY, 1989.
- [134] M. Gardner, *Fractal Music, Hypercards and More ...: Mathematical Recreations from Scientific American Magazine*, Freeman, New York, NY, 1992.
- [135] M. Gardner, *The Last Recreations: Hydras, Eggs, and Other Mathematical Mystifications*, Copernicus, New York, NY, 1997.
- [136] M. Gardner, *Riddles of the Sphinx And Other Mathematical Puzzle Tales*, Mathematical Association of America, Washington, DC, 1987.
- [137] M. Gardner, *The Colossal Book of Mathematics*, Norton, New York, NY, 2001.

- [138] M. Gardner, *Gardner's Workout: Training the Mind and Entertaining the Spirit*, A K Peters, Natick, MA, 2001.
- [139] M. J. Gazalé, *Gnomon: From Pharaohs to Fractals*, Princeton University Press, Princeton, NJ, 1999.
- [140] P. Gerdes, *Geometry from Africa: Mathematical and Educational Explorations*, Mathematical Association of America, Washington, DC, 1999.
- [141] M. Gessen, *Perfect Rigor*, Houghton Mifflin Harcourt, New York, NY, 2009.
- [142] M. Ghyka, *The Geometry of Art and Life*, Dover, New York, NY, 1977.
- [143] J. Gies and F. Gies, *Leonard of Pisa and the New Mathematics of the Middle Ages*, Crowell, New York, NY, 1969.
- [144] C. C. Gillispie, *Biographical Dictionary of Mathematicians, Volumes 1-4*, Charles Scribners' Sons, New York, NY, 1970-1991.
- [145] J. W. von Goethe, *Theory of Colours*, MIT, Cambridge, MA, 1970.
- [146] S. W. Golomb, "Replicating Figures in the Plane" in *The Changing Shape of Geometry*, C. Pritchard (Editor), Cambridge University Press, Cambridge, 2003, pp. 367-370.
- [147] J. M. Gordon, A. M. Goldman, J. Maps, D. Costello, R. Tiberio, and B. Whitehead, "Superconducting-Normal Phase Boundary of a Fractal Network in a Magnetic Field", *Physical Review Letters*, Vol. 56, No. 21 (1986), pp. 2280-2283.
- [148] P. Gorman, *Pythagoras: A Life*, Routledge & Kegan Paul, London, 1979.
- [149] R. L. Graham, "On Partitions of an Equilateral Triangle", *Canadian Journal of Mathematics*, Vol. XIX, No. 2 (1967), pp. 394-409.
- [150] R. L. Graham and B. D. Lubachevsky, "Dense Packings of Equal Disks in an Equilateral Triangle: From 22 to 34 and Beyond", *Electronic Journal of Combinatorics*, Vol. 2, No. 1, A1 (1995), pp. 1-39.
- [151] I. Grattan-Guinness, *Convolutions in French Mathematics, 1800-1840*, Birkhäuser Verlag, Basel, 1990.
- [152] J. E. Graver, *Counting on Frameworks: Mathematics to Aid the Design of Rigid Structures*, Mathematical Association of America, Washington, DC, 2001.

- [153] C. Green, *Triangular Philatelics: A Guide for Beginning to Advanced Collectors*, Krause Publications, Iola, WI, 1998.
- [154] A. D. Greenberg, *Chemical History Tour, Picturing Chemistry from Alchemy to Modern Molecular Science*, Wiley-Interscience, New York, NY, 2000.
- [155] S. L. Greitzer, *International Mathematical Olympiads 1959-1977*, Mathematical Association of America, Washington, DC, 1978.
- [156] B. Grünbaum and G. C. Shephard, *Tilings and Patterns*, W. H. Freeman and Co., New York, NY, 1987.
- [157] O. Gupta, *Encyclopaedia of India, Pakistan and Bangladesh*, Gyan Publishing House, New Delhi, 2006.
- [158] E. Gutkin, “Two Applications of Calculus to Triangular Billiards”, *American Mathematical Monthly*, Vol. 104, No. 7 (August-September 1997), pp. 618-622.
- [159] R. K. Guy, *Unsolved Problems in Number Theory*, Second Edition, Springer-Verlag, New York, NY, 1994.
- [160] T. Hall, *Carl Friedrich Gauss: A Biography*, MIT, Cambridge, MA, 1970.
- [161] P. R. Halmos, *Problems for Mathematicians, Young and Old*, Mathematical Association of America, Washington, DC, 1991.
- [162] P. Hamlyn and E. Friedman, “Partridge Numbers”, *Geombinatorics*, Vol. XIII, No. 1 (2003), pp. 10-18.
- [163] M. Hargittai and I. Hargittai, *Visual Symmetry*, World Scientific, Singapore, 2009.
- [164] T. L. Heath, *The Thirteen Books of Euclid's Elements*, Second Unabridged Edition, Dover, New York, NY, 1956.
- [165] T. L. Heath, *A History of Greek Mathematics, Volume I: From Thales to Euclid*, Dover, New York, NY, 1981.
- [166] T. L. Heath, *A History of Greek Mathematics, Volume II: From Aristarchus to Diophantus*, Dover, New York, NY, 1981.
- [167] T. L. Heath, *Apollonius of Perga*, W. Heffer & Sons, Cambridge, 1961.
- [168] T. L. Heath, *The Works of Archimedes*, Dover, Mineola, NY, 2002.

- [169] H. Hellman, *Great Feuds in Mathematics*, Wiley, Hoboken, NJ, 2006.
- [170] P. Hemenway, *Divine Proportion: Φ In Art, Nature, and Science*, Sterling, New York, NY, 2005.
- [171] D. Hestenes, *New Foundations for Classical Mechanics*, D. Reidel, Dordrecht, 1987.
- [172] D. Hilbert and S. Cohn-Vossen, *Geometry and the Imagination*, Chelsea, New York, NY, 1952.
- [173] Y. Hioka and N. Hamada, "A Tracking Algorithm of Speaker Direction Using Microphones Located at Vertices of Equilateral-Triangle", *European Signal Processing Conference*, Vienna, Austria (2004), pp. 1983-1986.
- [174] C. Hodapp, *Freemasons for Dummies*, Wiley, Hoboken, NJ, 2005.
- [175] P. Hoffman, *The Man Who Loved Only Numbers: The Story of Paul Erdős and the Search for Mathematical Truth*, Hyperion, New York, NY, 1998.
- [176] L. Hogben, *Mathematics for the Million*, Norton, New York, NY, 1983.
- [177] R. Honsberger, *Ingenuity in Mathematics*, Mathematical Association of America, Washington, DC, 1970.
- [178] R. Honsberger, *Mathematical Gems*, Mathematical Association of America, Washington, DC, 1973.
- [179] R. Honsberger, *Mathematical Morsels*, Mathematical Association of America, Washington, DC, 1978.
- [180] R. Honsberger, *Mathematical Plums*, Mathematical Association of America, Washington, DC, 1979.
- [181] R. Honsberger, *Mathematical Gems III*, Mathematical Association of America, Washington, DC, 1985.
- [182] R. Honsberger, *In Pólya's Footsteps*, Mathematical Association of America, Washington, DC, 1997.
- [183] R. Honsberger, *Mathematical Chestnuts from Around the World*, Mathematical Association of America, Washington, DC, 2001.
- [184] R. Honsberger, *Mathematical Delights*, Mathematical Association of America, Washington, DC, 2004.

- [185] A. A. Hopkins, *Scientific American Handy Book of Facts and Formulas*, Munn & Co., New York, NY, 1918.
- [186] E. How, *How to Read an Anemometer*, http://www.ehow.com/how_2074392_read-anemometer.html.
- [187] L. R. Hubbard, *Dianetics: The Modern Science of Mental Health*, Hermitage House, New York, NY, 1950.
- [188] R. P. Jerrard and J. E. Wetzel, "Equilateral Triangles and Triangles", *American Mathematical Monthly*, Vol. 109, No. 10 (December 2002), pp. 909-915.
- [189] R. A. Johnson, *Advanced Euclidean Geometry*, Dover, Mineola, NY, 2007.
- [190] J. Kappraff, *Connections: The Geometric Bridge Between Art and Science*, McGraw-Hill, New York, NY, 1991.
- [191] N. D. Kazarinoff, *Geometric Inequalities*, Mathematical Association of America, Washington, DC, 1961.
- [192] L. M. Kelly, "Equilateral Feeble Four-Point Property" in *The Geometry of Metric and Linear Spaces*, L. M. Kelly (Editor), Springer-Verlag, New York, NY, 1975, pp. 14-16.
- [193] M. Khanna, *Yantra: The Tantric Symbol of Cosmic Unity*, Inner Traditions, Rochester, VT, 2003.
- [194] J. Kingston and J. L. Synge, "The Sequence of Pedal Triangles", *American Mathematical Monthly*, Vol. 95, No. 7 (August-September 1988), pp. 609-620.
- [195] M. S. Klamkin, *International Mathematical Olympiads 1979-1985 and Forty Supplementary Problems*, Mathematical Association of America, Washington, DC, 1986.
- [196] M. S. Klamkin, *USA Mathematical Olympiads 1972-1986*, Mathematical Association of America, Washington, DC, 1988.
- [197] M. Kline, *Mathematics in Western Culture*, Oxford University Press, New York, NY, 1953.
- [198] D. E. Knuth, "Billiard Balls in an Equilateral Triangle", *Recreational Mathematics Magazine*, Vol. 14 (January-February 1964), pp. 20-23.

- [199] M. Kraitchik, *Mathematical Recreations*, Second Revised Edition, Dover, New York, NY, 1942.
- [200] M. E. Kuczma, *International Mathematical Olympiads 1986-1999*, Mathematical Association of America, Washington, DC, 2003.
- [201] A. Lakshminarayan, *Beautiful Math in Pillars of an Ancient Chennai Temple*, <http://bokonon.sulekha.com/blog/post/2007/04/beautiful-math-in-pillars-of-an-ancient-chennai-temple.htm>.
- [202] F. Lasserre, *The Birth of Mathematics in the Age of Plato*, American Research Council, Larchmont, NY, 1964.
- [203] D. Laugwitz, *Bernhard Riemann (1826-1866): Turning Points in the Conception of Mathematics*, Birkhäuser, Boston, MA, 2008.
- [204] R. Lawlor, *Sacred Geometry: Philosophy and Practice*, Thames and Hudson, London, 1982.
- [205] P. D. Lax, “The Ergodic Character of Sequences of Pedal Triangles”, *American Mathematical Monthly*, Vol. 97, No. 5 (May 1990), pp. 377-381.
- [206] A. H. Layard, *Discoveries in the Ruins of Ninevah and Babylon*, John Murray, London, 1853.
- [207] J. R. Lewis, *Scientology*, Oxford University Press, New York, NY, 2009.
- [208] S. Linkwitz, “Mapping from Recording to Playback” from *Recording for Stereo*, Linkwitz Lab, <http://www.linkwitzlab.com/Recording/record-play-map.htm>, Accessed 05 June 2010.
- [209] A. L. Loeb, *Space Structures: Their Harmony and Counterpoint*, Birkhäuser, Boston, MA, 1991.
- [210] S. Loyd, *Sam Loyd’s Cyclopedia of 5000 Puzzles Tricks & Conundrums with Answers*, Ishi Press International, Bronx, NY, 2007.
- [211] S. Loyd, *Mathematical Puzzles of Sam Loyd, Volume One*, M. Gardner (Editor), Dover, Mineola, NY, 1959.
- [212] S. Loyd, *Mathematical Puzzles of Sam Loyd, Volume Two*, M. Gardner (Editor), Dover, Mineola, NY, 1960.
- [213] P. A. MacMahon, *New Mathematical Pastimes*, Cambridge University Press, Cambridge, 1921.
- [214] J. S. Madachy, *Madachy’s Mathematical Recreations*, Dover, Mineola, NY, 1966.

- [215] B. Mahon, *The Man Who Changed Everything: The Life of James Clerk Maxwell*, Wiley, Chichester, 2003.
- [216] M. S. Mahoney, *The Mathematical Career of Pierre de Fermat*, Second Edition, Princeton University Press, Princeton, NJ, 1994.
- [217] M. Majewski and J. Wang, “A Journey through Chinese Windows and Doors: An Introduction to Chinese Mathematical Art”, *Proceedings of the Fourteenth Asian Technology Conference in Mathematics*, Beijing, China, December 17-21, 2009, http://atcm.mathandtech.org/EP2009/papers_invited/2812009_17224.pdf.
- [218] B. J. McCartin, “Prelude to Musical Geometry”, *College Mathematics Journal*, Vol. 29, No. 5 (November 1998), pp. 354-370.
- [219] B. J. McCartin, *Laplacian Eigenstructure of the Equilateral Triangle*, Hikari, 2011.
- [220] H. Melissen, “Densest Packings of Congruent Circles in an Equilateral Triangle”, *American Mathematical Monthly*, Vol. 100, No. 10 (December 1993), pp. 916-925.
- [221] H. O. Midonick, *The Treasury of Mathematics*, Philosophical Library, New York, NY, 1965.
- [222] P. Murray and L. Murray, *The Oxford Dictionary of Christian Art*, Oxford University Press, Oxford, 2004.
- [223] J. R. Musselman, “On Equilateral Triangles”, *American Mathematical Monthly*, Vol. 39, No. 5 (1932), pp. 290-292.
- [224] P. J. Nahin, *When Least is Best*, Princeton University Press, Princeton, NJ, 2004.
- [225] S. Nephew, *Equilateral Triangular Patchwork*, Dover, Mineola, NY, 1986.
- [226] R. Netz and W. Noel, *The Archimedes Codex*, Da Capo, Philadelphia, PA, 2007.
- [227] Sir I. Newton, *Philosophiæ Naturalis Principia Mathematica*, University of California, Berkeley, CA, 1934.
- [228] I. Niven, *Maxima and Minima Without Calculus*, Mathematical Association of America, Washington, DC, 1981.

- [229] T. H. O’Beirne, *Puzzles and Paradoxes*, Oxford University Press, New York, NY, 1965.
- [230] J. J. O’Connor and E. F. Robertson, *The MacTutor History of Mathematics*, <http://www-history.mcs.st-andrews.ac.uk/Biographies/>, 2010.
- [231] C. S. Ogilvy, *Excursions in Geometry*, Dover, Mineola, NY, 1990.
- [232] A. Okabe, B. Boots and K. Sugihara, *Spatial Tessellations: Concepts and Applications of Voronoi Diagrams*, Wiley, Chichester, 1992.
- [233] D. J. O’Meara, *Pythagoras Revived: Mathematics and Philosophy in Late Antiquity*, Oxford University Press, Oxford, 1989.
- [234] T. Orton, “From Tessellations to Fractals” in *The Changing Shape of Geometry*, C. Pritchard (Editor), Cambridge University Press, Cambridge, 2003, pp. 401-405.
- [235] J. Pach and R. Pinchasi, “How Many Unit Equilateral Triangles Can Be Generated by N Points in Convex Position?”, *American Mathematical Monthly*, Vol. 110, No. 5 (May 2003), pp. 400-406.
- [236] D. Parlett, *The Oxford History of Board Games*, Oxford University Press, Oxford, 1999.
- [237] D. Pedoe, *Circles: A Mathematical View*, 2nd Edition, Mathematical Association of America, Washington, DC, 1995.
- [238] E. Pegg, “The Eternity Puzzle”, *Math Puzzle: The Puzzling Weblog of Recreational Mathematics*, <http://mathpuzzle.com/eternity.html>.
- [239] H.-O. Peitgen, H. Jürgens and D. Saupe, *Chaos and Fractals: New Frontiers in Science*, Springer-Verlag, New York, NY, 1992.
- [240] I. Peterson, *Fragments of Infinity: A Kaleidoscope of Math and Art*, Wiley, New York, NY, 2001.
- [241] I. Peterson, *Mathematical Treks: From Surreal Numbers to Magic Circles*, Mathematical Association of America, Washington, DC, 2002.
- [242] C. A. Pickover, *The Math Book*, Sterling, New York, NY, 2009.
- [243] G. Pólya and G. Szegő, *Isoperimetric Inequalities in Mathematical Physics*, Princeton University Press, Princeton, NJ, 1951.
- [244] L. Pook, *Flexagons Inside Out*, Cambridge University Press, Cambridge, 2003.

- [245] A. S. Posamentier and I. Lehmann, *Mathematical Amazements and Surprises: Fascinating Figures and Noteworthy Numbers*, Prometheus, Amherst, NY, 2009.
- [246] A. S. Posamentier and C. T. Salkind, *Challenging Problems in Geometry*, Dover, Mineola, NY, 1996.
- [247] K. A. Post, "Triangle in a Triangle: On a Problem of Steinhaus", *Geometriae Dedicata*, Vol. 45, No. 1 (January 1993), pp. 115-120.
- [248] A. Powell, *John Aubrey and His Friends*, Hogarth, London, 1988.
- [249] H. Rademacher and O. Toeplitz, *The Enjoyment of Mathematics: Selections from Mathematics for the Amateur*, Princeton University Press, Princeton, NJ, 1966.
- [250] G. Rawlinson, *The Five Great Monarchies of the Ancient Eastern World*, Volume II, John Murray, London, 1864.
- [251] H. B. Reiter, *The Contest Problem Book VII: 1995-2000*, Mathematical Association of America, Washington, DC, 2006.
- [252] D. S. Richeson, *Euler's Gem*, Princeton University Press, Princeton, NJ, 2008.
- [253] J. F. Rigby, "Equilateral Triangles and the Golden Ratio" in *The Changing Shape of Geometry*, C. Pritchard (Editor), Cambridge University Press, Cambridge, 2003, pp. 292-295.
- [254] S. Roberts, *King of Infinite Space: Donald Coxeter, the Man Who Saved Geometry*, Walker, New York, NY, 2006.
- [255] W. Roberts, *Principles of Nature: Towards a New Visual Language*, W. A. Roberts, Canberra, 2003.
- [256] A. Robson, *An Introduction to Analytical Geometry, Volume I*, Cambridge University Press, Cambridge, 1940.
- [257] A. Robson, *An Introduction to Analytical Geometry, Volume II*, Cambridge University Press, Cambridge, 1947.
- [258] T. S. Row, *Geometric Exercises in Paper Folding*, Dover, New York, NY, 1966.
- [259] P. S. Rudman, *The Babylonian Theorem: The Mathematical Journey to Pythagoras and Euclid*, Prometheus, Amherst, 2010.

- [260] B. Russell, “The Teaching of Euclid” in *The Changing Shape of Geometry*, C. Pritchard (Editor), Cambridge University Press, Cambridge, 2003, pp. 486-488.
- [261] D. G. Saari, *Basic Geometry of Voting*, Springer-Verlag, Berlin, 1995.
- [262] C. T. Salkind, *The Contest Problem Book I: 1950-1960*, Mathematical Association of America, Washington, DC, 1964.
- [263] C. T. Salkind, *The Contest Problem Book II: 1961-1965*, Mathematical Association of America, Washington, DC, 1966.
- [264] C. T. Salkind and J. M. Earl, *The Contest Problem Book III: 1966-1972*, Mathematical Association of America, Washington, DC, 1973.
- [265] C. E. Sandifer, *The Early Mathematics of Leonhard Euler*, Mathematical Association of America, Washington, DC, 2007.
- [266] C. E. Sandifer, *How Euler Did It*, Mathematical Association of America, Washington, DC, 2007.
- [267] S. Savchev and T. Andreescu, *Mathematical Miniatures*, Mathematical Association of America, Washington, DC, 2003.
- [268] D. Schattschneider, *Visions of Symmetry: Notebooks, Periodic Drawings, and Related Works of M. C. Escher*, Freeman, New York, NY, 1990.
- [269] B. Schechter, *My Brain Is Open: The Mathematical Journeys of Paul Erdős*, Simon & Schuster, New York, NY, 1998.
- [270] L. J. Schneider, *The Contest Problem Book VI: 1989-1994*, Mathematical Association of America, Washington, DC, 2000.
- [271] M. S. Schneider, *A Beginner’s Guide to Constructing the Universe: The Mathematical Archetypes of Nature, Art, and Science*, Harper Perennial, New York, NY, 1995.
- [272] I. J. Schoenberg, *Mathematical Time Exposures*, Mathematical Association of America, Washington, DC, 1982.
- [273] F. Schuh, *The Master Book of Mathematical Recreations*, Dover, New York, NY, 1968.
- [274] C. Scott, “Adventures in Amplified GPS Antenna Construction: An Experiment”, *RF Cafe* (1994), <http://www.rfcafe/references/resources/gps.htm>.

- [275] J. G. Semple and G. T. Kneebone, *Algebraic Projective Geometry*, Oxford University Press, Oxford, 1952.
- [276] R. Shesso, *Math for Mystics*, Weiser, San Francisco, CA, 2007.
- [277] D. O. Shklarsky, N. N. Chentzov and I. M. Yaglom, *The USSR Olympiad Problem Book: Selected Problems and Theorems of Elementary Mathematics*, Dover, Mineola, NY, 1993.
- [278] G. Sholem, “The Curious History of the Six Pointed Star; How the *Magen David* Became the Jewish Symbol”, *Commentary*, Vol. 8 (1949), pp. 243-351.
- [279] L. S. Sieden, *Buckminster Fuller’s Universe: His Life and Work*, Perseus, Cambridge, MA, 1989.
- [280] P. Sijen, “Reference Listening Position” from *Speaker Placement*, AudioDesignLabs, <http://audiodesignlabs.com/wordpress/2008/05/stereo-and-surround-speaker-placement/#more-12>, May 9, 2008.
- [281] J. Sikorska and T. Szostok, “On Mappings Preserving Equilateral Triangles”, *Journal of Geometry*, Vol. 80, Nos. 1-2 (August 2004), pp. 209-218.
- [282] J. Sikorska and T. Szostok, “On Mappings Preserving Equilateral Triangles in Normed Spaces”, *Journal of Geometry*, Vol. 85, Nos. 1-2 (September 2006), pp. 149-156.
- [283] S. Singh, *Fermat’s Enigma*, Walker, New York, NY, 1997.
- [284] D. Singmaster, “Triangles with Integer Sides and Sharing Barrels”, *College Mathematics Journal*, Vol. 21, No. 4 (September 1990), pp. 278-285.
- [285] S. Skinner, *Sacred Geometry: Deciphering the Code*, Sterling, New York, NY, 2006.
- [286] N. J. A. Sloane, “Error-Correcting Codes in Cryptography” in *Mathematical Recreations: A Collection in Honor of Martin Gardner*, D. A. Klarner (Editor), Dover, Mineola, NY, 1998, pp. 346-382.
- [287] D. E. Smith, *A Source Book in Mathematics*, McGraw-Hill, New York, NY, 1929.
- [288] G. Springer, *Introduction to Riemann Surfaces*, Addison-Wesley, Reading, MA, 1957.
- [289] D. Srejovic, *Europe’s First Monumental Sculpture: New Discoveries at Lepenski Vir*, Stein and Day, New York, NY, 1972.

- [290] S. K. Stein, *Mathematics: The Man-Made Universe*, Third Edition, Dover, Mineola, NY, 1999.
- [291] H. Steinhaus, *Mathematical Snapshots*, Third American Edition, Oxford University Press, Oxford, 1969.
- [292] H. Steinhaus, *One Hundred Problems in Elementary Mathematics*, Dover, New York, NY, 1979.
- [293] I. Stewart, “Tales of Neglected Number”, *Scientific American*, Vol. 274 (June 1996), pp. 102-103.
- [294] I. Stewart, “Feedback”, *Scientific American* (July 1997), p.96; August 1998, p. 97; March 1999, p. 106.
- [295] I. Stewart, *Professor Stewart’s Cabinet of Mathematical Curiosities*, Basic Books, New York, NY, 2008.
- [296] I. Stewart, *Professor Stewart’s Hoard of Mathematical Treasures*, Basic Books, New York, NY, 2009.
- [297] D. J. Struik, *A Source Book in Mathematics, 1200-1800*, Princeton University Press, Princeton, NJ, 1986.
- [298] J. W. N. Sullivan, *Isaac Newton: 1642-1727*, Macmillan, New York, NY, 1938.
- [299] F. Suzuki, “Tumugu Sakuma’s Problem”, *Mathematical Gazette*, Vol. 85, No. 503 (July 2001), pp. 233-238.
- [300] F. Suzuki, “An Equilateral Triangle with Sides through the Vertices of an Isosceles Triangle”, *Mathematics Magazine*, Vol. 74, No. 4 (October 2001), pp. 304-310.
- [301] G. G. Szpiro, *Kepler’s Conjecture*, Wiley, New York, NY, 2003.
- [302] D. Taimina, *Crocheting Adventures with Hyperbolic Planes*, A K Peters, Wellesley, MA, 2009.
- [303] D. Taimina and D. W. Henderson, “Reuleaux Triangle”, *Kinematic Models for Design Digital Library*, <http://kmoddl.library.cornell.edu/tutorials/02/>, Accessed 08 February 2010.
- [304] R. Thiele, “Mathematics in Göttingen (1737-1866)”, *Mathematical Intelligencer*, Vol. 16, No. 4 (1994), pp. 50-60.

- [305] H. Tietze, *Famous Problems in Mathematics: Solved and Unsolved Mathematical Problems from Antiquity to Modern Times*, Graylock, Baltimore, MD, 1965.
- [306] R. Todev, *Geometry Problems from Mathematical Olympiads*, CreateSpace, Scotts Valley, CA, 2010.
- [307] I. Tolstoy, *James Clerk Maxwell: A Biography*, Cannongate, Edinburgh, 1981.
- [308] M. Trenkler, “Magic Stars”, *ΠME Journal*, Vol. 11, No. 10 (2004), pp. 549-554.
- [309] W. T. Tutte, “The Dissection of Equilateral Triangles into Equilateral Triangles”, *Proceedings of the Cambridge Philosophical Society, Mathematical and Physical Sciences*, Vol. 44 (1948), pp. 463-482.
- [310] W. T. Tutte, “Dissections into Equilateral Triangles” in *Mathematical Recreations: A Collection in Honor of Martin Gardner*, D. A. Klarner (Editor), Dover, Mineola, NY, 1998, pp. 346-382.
- [311] M. C. K. Tweedie, “A Graphical Method for Solving Tartaglian Measuring Puzzles”, *Mathematical Gazette*, Vol. 23 (July 1939), pp. 278-282.
- [312] J. Von Neumann and O. Morgenstern, *Theory of Games and Economic Behavior*, Princeton University Press, Princeton, NJ, 1953.
- [313] M. Wainwright, “Prize Specimens”, *Plus*, Issue 13 (January 2001), <http://plus.maths.org/issue13/features/eternity/index.html>.
- [314] H. Walser, *The Golden Section*, Mathematical Association of America, Washington, DC, 2001.
- [315] H. Walser, *Fibonacci in the Triangular Lattice*, http://www.math.unibas.ch/~walser/Miniaturen/F/Fibonacci_Triangle/Fibonacci_Triangle.htm, 2009.
- [316] J. J. Watkins, *Across the Board: The Mathematics of Chessboard Problems*, Princeton University Press, Princeton, NJ, 2004.
- [317] Weather Station, *Wind Speed and Direction (Ultrasonic Anemometer 2D)*, Essendon Bushwalking Club, Victoria, Australia, <http://trekker.customer.netspace.net.au/wind.htm>.
- [318] J. R. Weeks, *The Shape of Space*, Second Edition, Marcel Dekker, New York, NY, 2002.

- [319] A. Weil, *Number Theory: An approach through history; From Hammurapi to Legendre*, Birkhäuser, Boston, MA, 1984.
- [320] E. W. Weisstein, *CRC Concise Encyclopedia of Mathematics*, CRC, Boca Raton, FL, 1999.
- [321] D. Wells, “Are These the Most Beautiful?”, *Mathematical Intelligencer*, Vol. 12, No. 3 (1990), pp. 37-41.
- [322] D. Wells, *The Penguin Dictionary of Curious and Interesting Geometry*, Penguin, London, 1991.
- [323] D. Wells and J. D. Faires, *The Contest Problem Book IX (AMC 12): 2001-2007*, Mathematical Association of America, Washington, DC, 2008.
- [324] R. S. Westfall, *Never at Rest: A Biography of Isaac Newton*, Cambridge University Press, New York, NY, 1980.
- [325] J. E. Wetzel, “The Smallest Equilateral Cover for Triangles of Perimeter Two”, *Mathematics Magazine*, Vol. 70, No. 2 (April 1997), pp. 125-130.
- [326] J. E. Wetzel, “Fits and Covers”, *Mathematics Magazine*, Vol. 76, No. 5 (December 2003), pp. 349-363.
- [327] H. Weyl, *Symmetry*, Princeton University Press, Princeton, NJ, 1952.
- [328] M. White, *Isaac Newton: The Last Sorcerer*, HarperCollins, London, 1998.
- [329] D. Whyte, *Hana-Gusari Mail*, http://www.artofchainmail.com/patterns/japanese/hana_gusari.html, 2006.
- [330] Wikipedia, *The Free Encyclopedia*, <http://en.wikipedia.org/wiki/>, 2010.
- [331] S. H. Wu and M. Bencze, “An Equivalent Form of the Fundamental Triangle Inequality and Its Applications”, *Journal of Inequalities in Pure and Applied Mathematics*, Vol. 10 (2009), Article 16, 6 pp.
- [332] B. H. Yandell, *The Honors Class: Hilbert’s Problems and Their Solvers*, A. K. Peters, Natick, MA, 2002.
- [333] Z. Yuhuan and L. Zewen, *Ancient Chinese Pagodas*, Science Press, Beijing, 1995.
- [334] M. G. Zabetakis, “Flammability Characteristics of Combustible Gases and Vapors”, *US Bureau of Mines, Bulletin 627* (1965).

Index

- Abel, Niels 165
abutting equilateral triangles 47
Acta Arithmetica 175
Adams Prize 168
ad triangulum 18
Aer 9
affine geometry 51
air-line 86
Airy, Sir George 171
Albanfriedhof cemetery 165
alchemical symbols 24
alchemy v, 21, 24, 160-161
*Alice's Adventures in Wonderland /
Through the Looking Glass*
169
alleles 90
All-Union Russian Olympiad 139
altar (triangular) 4
American Journal of Mathematics
172
American Mathematical Monthly 69
American Mathematical Society 172,
179, 182
American Mathematics Competition
(AMC) 129-136
Amusements in Mathematics 181
analysis of algorithms 180
Anaximander 149
Angels and Devils Game 169
antenna design vi, 79-81
anticevian corner triangles 39
antipedal triangle 36, 39
Apollonius circles 38, 152
Apollonius of Perga 150-152, 158,
165, 183
Apollonius points 38, 152
Appell, Paul 166
applications vi, 78-102
Applied Mathematics v-vi, 101
Aqua 9
Archbishop's Coat of Arms 10
Archimedean solid 13, 151, 155
Archimedean spiral 152
Archimedes Codex 151
Archimedes of Syracuse 13, 150-151,
154, 158, 183
Archimedes screw 151
ARC triangle 24
areal coordinates 33
Aristotle 149
Arithmetica Infinitorum 76
Ars Magna 154
Artin, Emil 175
Art of Computer Programming 180
Asshur-izir-pal 4
Astronomia Nova 155
Athene 10
Aubrey, John 148
augmented triad 25
Aum 5
Austrian-Polish Mathematics Com-
petition 138, 141
Babylonian clay tablet 3, 4
Babylonian cuneiform 4
Babylonian cylinder 3, 4
Babylon 5 27-28
Baire, René 174
Baker, H. F. 176
Ball, W. W. Rouse 176

- Barbier's Theorem 56
 barrel sharing problems 121-123
 Barrow, Isaac 160
 barycentric coordinates 33
 Basel Problem 161
 basic properties 29-30
 Bath College 171
 Baxter, A. M. 120
 Beeckman, Isaac 156
 Beeson, M. J. 61
 Beethoven, Ludwig van 25
 Belarusian Mathematical Olympiad
 140
 Bell Telephone Laboratories 178
 Bent Pyramid (Dashur) 2
 Berlin Academy 161
 Bernoulli, Daniel 161
 Bernoulli, Johann 161
 Bertrand, Joseph 166, 185
 Bertrand's Paradox 109, 166
 Bessel, F. W. 164
 Biefeld-Brown effect 84
 billiard ball packing 94
 billiard ball problem 118
 bination 69
 binomial coefficients 59
 binomial theorem 160
Biographical Dictionary of Mathematicians vi
 biographical vignettes vi, 148-187
 biomimetic antenna ("Bat's Ear")
 80-81
 black hole 84
 Blaschke, Josef 175
 Blaschke-Lebesgue Theorem 56, 174,
 176
 Blaschke's Theorem 45, 176
 Blaschke, Wilhelm 45, 175, 186
 Blundon's inequality v, 53
 Bodleian Library 150
 bombers (triangular) 189
The Book 177
 Borda voting 91
 Borel, Émile 174
 Borelli, Giovanni Alfonso 158
 Borromean rings 26
 bowling pins (triangular) 192
 Brahe, Tycho 155
 Brahma 5
 Brahms, Johannes 25
Brief Lives 148
 Briggs, Henry 148
 Brotherhood of the Rosy Cross 21
 Brown, T. T. 84
 Brunnian link 5
 Buchman, E. 70
 buckminsterfullerene 176
 buckyball 176
 Budapest University of Art and Design 128
 Buddha 6
 Buddhism v
 building (triangular) 197
 Bulgarian Mathematical Olympiad
 139-140
 Burgiel, H. 26
 butterfly (triangular) 23, 98
 Butterfly Map 97-98
 Caesariano, Caesare 18-19
 Cahill, B. J. S. 97-98
 California Institute of Technology 178,
 180
 Calypso 83
 Cambridge University 168, 176, 180
camera obscura 155
Canterbury Puzzles 181
 Cantrell, David 45
 Cardano, Girolamo 154
 cardiac vector 81-82
 Carpenter's Plane 112
 cartography vi, 97-98
 Case Institute of Technology 180
 Castelli, Benedetto 157

- cat iii, 189
 Catholic Church 20
 Cauchy, Augustin-Louis 50
 Cauchy-Schwarz inequality 169
 Cavalieri, Bonaventura 157-158
 Cavendish Laboratory 168
 CBS Evening News 180
 cellular automata 179
 Center for New Music and Audio
 Technologies (CNMAT) 94
 centroid 30, 46
 Ceres 164
 cevian triangle 38
 chainmail (triangular) 7-8
 chair (triangular) 195
 Chaos Game 59-60
 Chartres Cathedral 22
 Chebyshev, Pafnuty 165
 Chekov, Ensign 27
 Chennai Temple 5
 Cheops (Khufu) 2
Chess Strategy 181
 Chinese Checkers 16
 Chinese Remainder Theorem 153
 Chinese window lattices 6
 Chongsheng Monastery 6
 chord progressions 25
 Chou Dynasty 6
 Christian art 18
 Christianity v, 22
 Christian mysticism 22
Christ of Saint John of the Cross
 17-18
 chromaticity 88
 Chung, Fan 179
 church (triangular) 197
 church window (triangular) 196
 Chu shih-chieh 59
 Ciampoli, Giovanni 157
 Cipra, B. 43
 circle-of-fifths 25
 circumcenter 30, 46
 circumcevian triangle 39
 circumcircle 30, 52, 69, 76
 circumscribing rectangle 47
 City College of New York 174
 Clark, Andrew 148
 classification of cubic curves 160
 Cloak of Invisibility 28
 closed light paths 54-55
 Collège de France 166, 174
 College of Invisibles 21
 College of San Francesco Saverio 162
 Collegio della Sapienza 157
 Collegium Carolinum (TU Braun-
 schweig) 163-164
 Coltrane, John 25
Combinatory Analysis 171
 Companion (Gothic) 20
 Computational Confectionery 100
Computer-Generated Encyclopedia of
 Euclidean Geometry 38
 Condorcet voting 91
Conics 151
 constructions v, 30
 convex tilings 71
 Conway, John Horton 43, 123, 179,
 187, 180
 Conway's Soldiers 179
 Copernicus 155
 Corea, Chick 24
 corner triangles 38-39
 covering properties 45
 coverings v, 45
 Coxeter groups 176
 Coxeter, H. S. M. 25, 69, 176, 187
 Coxeter polytopes 176
 CO₂ emissions 100
 Cratylus 149
 Crelle, August 165
 Crelle's Journal 165
 crochet model (hyperbolic plane) 75
 Cronkite, Walter 180
 cross formée 20

- Cruise, Tom 24
 Crusades 20
 crystals (triangular) 191
 cube 11, 15, 117
 cuboctahedron 13
 cucumber (triangular) 23
Curiosa Mathematica 147, 169
 curves of constant breadth (width)
 56
Cyclopedia of Puzzles 181
- Dali, Salvador 17, 18
 danger sign (triangular) 195
 Davenport, Harold 179
 Davis, Miles 25
 Davis, Philip J. v
De Analysi 160
De Architectura 18
Deathly Hallows 28
 Decad 10
 deceptahedron 14, 15
 Dedekind, Richard 164
De Divina Proportione 11, 153
 De Finetti diagram 34, 90
 Dekov, D. 38
 Delahaye, J.-P. 76
 Delahaye product 76
 Delenn, Ambassador 27-28
 deltahedron 14, 15
 Demaine, Erik D. 100
 De Moivre, Abraham 125
 densest packing of circles 61
 Desargues, Girard 159
 Descartes, René 11, 21, 148, 151-
 152, 156, 161, 184
 Descartes' Rule of Signs 156
 diameter of a plane set 73
 Dianetics 24
 diatonic scale 25
 die (triangular) 192
 difference triangle 117-118
 dihedral group 67
 diminished triad 25
 Dione 83
 Diophantus 153, 157
 diploid 90
 Dirichlet boundary condition 102
 Dirichlet, P. G. Lejeune 167
 Dirichlet tessellation 62
Disquisitiones Arithmeticae 164
 Dissected Triangle Puzzle 104
 dissection into isosceles triangles 107
 dissection into similar pieces 108
 dissection puzzles vi, 104-108
 distances from vertices 40
 dodecadeltahedron 15
 dodecahedron 15, 117
 Dodgson, Charles Lutwidge (Lewis
 Carroll) 127, 169, 185
 Doolan, E. P. 69
 Doomsday algorithm 169
 dragons 6
 Dreyfus affair 16
 ducks (triangular) 189
 Dudeney, Henry Ernest 104-105, 181,
 187
 Duhamel, J. M. C. 166
 Duke of Braunschweig 163-164
 Dyad 9
 Dymaxion Car 176
 Dymaxion House 176
 Dymaxion Skyocean Projection World
 Map 97, 176
- Earth 80, 84
 ecliptic 84
 École des Mines 170
 École Normale Supérieure 174
 École Polytechnique 166, 170
 Edo period 6
 effective amount (light) 88
 Eggleston, H. G. 45
eheleo funnel 8-9
 eigenvalues / eigenfunctions 101

- Einstein, A. 84, 167, 172
 Einthoven's Triangle (electrocardiography) 81-82
 Eisenstein, Gotthold 167
 Elder Wand 28
 electrical axis (heart) 81-82
 electrocardiography vi
 electrohydrodynamic (EHD) device 84
 electromagnetics 102
 electron microscopy 99
Elements iv, 1, 150, 161, 173
 ellipsoidal shape 34-35
 Emperor Justinian 150
 Emperor Rudolph II 155
 Eötvös Lorand University (Hungary) 177
 equation (equilateral triangle) 31
 equiangularity 69
 equilateral
 shadows 51
 spirals 69
 triangle i-vii, 1-198
 triangles and triangles 43
 Equilateral Triangle Method (surveying) 78
 Equilateral Triangle Rule (speaker placement) 92-93
 equilateral triangular
 anemometer 96
 billiards 118-120, 180
 fractals 58
 lattice 60-61, 120
 membrane 100-101
 microphone placement 92-93
 mosaic 61
 prism 100-101
 rotor 57
 equilic quadrilateral 48
 equitriangular unit of area (etu) 33
 Erdély, Dániel 128
 Erdős-Mordell inequality 53
 Erdős-Moser configuration 55
 Erdős number 177-178
 Erdős, Paul 177-178, 187
 Erdős Sphere Coloring Problem 110-111
 error-correcting code 91-92
 ESA 84
 Escher, Maurits 176, 194
Essay on Conic Sections 159
Essay on the Foundations of Geometry 173
 Eternity Puzzle 124-125
 ETH-Zurich 169, 172
 Euclidean geometry 126-127
 Euclid of Alexandria iv, 1, 30, 150-152, 154, 158, 183
 Eudoxus 149-150
 Euler, Leonhard 11, 125, 161, 184
 Euler line 46, 161
 Euler's inequality 52, 161
 Eves, Howard 66
 excenter 46
 excentral triangle 46
 excentral triangle iteration 46
 Eye of God 18
 Fagnano, Giovanni 54
 Fagnano, Giulio 54
 Fagnano orbit 118-120
 Fagnano Problem 54, 119, 170
 fallout shelter (triangular) 196
 Father 18
 Fejér, L. 177
 Fermat, Pierre de 35, 50, 153, 156, 159, 184
 Fermat point 35-36, 39, 158
 Fermat prime 164
 Fermat's Factorization Method 157
 Fermat's Last Theorem 157, 161
 Fermat's Little Theorem 157
 Fermat's Method of Descent 157
 Fermat's Polygonal Number Conjec-

- ture 157
 Fermat's Principle of Least Time 157
 Fermat-Torricelli Problem 35, 158-159
 Feynman, Richard P. 109
 Fibonacci numbers 67, 69, 153
 Fibonacci sequence 67, 70
 Fibonacci Triangle 67-68
 Fields Medal 151
 fighters (triangular) 189
 figurate numbers 32
Finite Semifields and Projective Planes 180
 Fisher, Irving 97-99
 Flag of Israel 16
 flag (triangular) 193
 flammability diagram 86-87
 flammability region 86
 flexagon 108-109
 Flexagon Committee 109
 Flint, J. A. 81
 Flint, Michigan 151
 Florentine enigma 159
 flower (triangular) 23
 Fludd, Robert 9
 fly (triangular) 23
 Fontana, Niccolò (Tartaglia) 154, 120, 183
 Foucault, Léon 158
 four elements 9-11, 24
 Four Squares Theorem 163
 Fourth Dynasty 2
 Four Triangle Sculpture 25
 fractal dimension 58
 Fraenkel, A. S. 123
 Freemasonry 20-21
 Free Will Theorem 169
 French Mathematical Olympiad 140
 Freudenthal, H. 15
 Friedman, Erich 44-45
 Frost, E. 15
 fullerenes 176
 Fuller, R. Buckminster 97-99, 176, 186
 fundamental domain 67
 fundamental mode 101
 Fundamental Theorem of Algebra 164
 fundamental triangle 90
Fundamenta Mathematica 175
 Fürst, Paul 100

 Galileo 157-158
Gallery of Equilateral Triangles vi, 26, 188-198
 Game of Life 169
Gamesters of Triskelion 27
 game theory vi, 90
 game (triangular) 192
 Gardner, Martin vi, 43, 119, 169, 179, 181-182, 187
 Gardner's Gaffe 119-120
 Garfunkel-Bankoff inequality 53
 Gateway Arch 26-27
 Gaussian curvature 164
 Gauss, Karl Friedrich 50, 163, 167, 185
 Gauss Plane 50, 164
 Gauss' Theorem on Triangular Numbers 50, 164
 Gazalé, M. J. 69
 geese (triangular) 189
 gem (triangular) 191
 General Theory of Relativity 84, 167, 172
 generating parallelogram 61
 genetics vi, 90
 genotype 90
 geodesic dome 99, 176, 195
 geometric spiral 69
Géométrie 156
Geometrie der Zahlen 172
 Geometry v
 Gerbert of Aurillac v
 Gergonne point 39

- Global Positioning System 80
- global warming 100
- gnana* 5
- gnomon 70
- Goethe color triangle 86-87
- Goldberg, Michael 66, 107
- golden
 - mean 2
 - ratio 68-69
 - section 13, 58, 153
- Golden Triangle Fractal 58
- Golomb, Solomon Wolf 112, 178, 187
- Gonville and Caius College, Cambridge 179
- Gordon, J. M. 94
- Gothic cathedral 18-19, 22
- Gothic masons 20
- GPS antenna 79-80
- Graham, Ronald Lewis 73, 177-178, 187
- Grand Architect of the Universe 21
- Grand Duke Ferdinando II de' Medici 157-158
- Grandi, Luigi Guido 159
- gravitational waves vi, 84
- Great Pyramid (Giza) 2, 3
- Greek Symbol Puzzle 103, 181
- Greenhill, Alfred George 171
- green pepper (triangular) 23
- Green, Trevor 45
- group of isometries 67
- Grunsky, H. 77
- Guinness Book of Records* 178

- Haberdasher's Puzzle 104
- Hales, Thomas 155
- Halley, Edmond 162
- Hall, Jr., Marshall 180
- Halma 16
- Hamada, N. 92
- Hamlyn, P. 72
- Hamming
 - code 92
 - distance 92
- hana gusari* 7-9
- handshake problem 32
- Harboth, Heiko 125
- Hardy-Weinberg frequency 90
- Harmonice Mundi* 15, 155
- Harriot, Thomas 148
- Harvard University 176, 178
- Hasse, Helmut 175
- hat (triangular) 193
- Haverford College 171
- Haydn, Franz Joseph 25
- heat transfer 102
- heccaidecadeltahedron 15
- Hecke, Erich 175
- Heiberg, J. L. 151
- Helene 83
- heliotrope 164
- Hellenic Mathematics 150
- Heraclitus 149
- Heraldic Cross 20
- Hermite, Charles 166, 170
- Hertz, Heinrich 169
- hexagon 10, 16, 107
- hexagram 10, 16
- hexiamonds 112, 112-114, 178
- Hilbert, David 172
- Hilbert's Eighth Problem 167
- Hilbert's Problems 172
- Hinduism v, 4, 5, 16
- hinged dissection 104-105
- Hioka, Y. 92
- history (equilateral triangle) v, 1-28
- hollow triangle 26
- Holy Lands 20
- Holy Spirit 18
- homogeneous coordinates 33-34
- honeydew melon (triangular) 23
- Hooke, Robert 160
- Hop Ching Checkers 16
- Hopkins, A. A. 30

- house (triangular) 197
 Hubbard, L. Ron 24
 Hudson River Psychiatric Center 69
 hue 88
 human elbow 82
 humor (triangular) 188
Humpty Dumpty Magazine 182
 Hungarian National Olympiad 141
 Hurwitz, Adolf 172
 Huyghens, Christiaan 160
 hyperbolic equilateral triangles 74
 hyperbolic plane
 (models) 75
 (standard) 74
- Iberoamerican Mathematical Olympiad
 (Mexico) 142
iccha 5
 Ice Age 2
 icosahedral speaker 94
 icosahedral symmetry 99
 icosahedron 11, 15, 97-99, 117
 icosidodecahedron 13
ida 5
 Ignis 9
 impossible triangle 196
 imputation vector 90
 incenter 30, 39
 incircle 30, 46, 56
 incircle-triangle iteration 46
 infinitely many linear equations 173
 inorganic chemistry 24
Intégrale, longeur, aire 174
International Juggler's Association
 179
 International Mathematical Olympiad
 129, 137-138, 143
Introduction to Geometry 176
Intuition 25-26
 ionic wind 85
 ionocraft 84-85
 Irish Mathematical Olympiad 139,
- 144
 Iron Cross 20
 isodynamic points 38-39
 isogonic center 35-36
 isometry 75
 Isoperimetric Theorem 52
- Jacobi, C. G. 50, 165, 167
 Jagiellonian University (Kraków) 175
 Jansenism 159
 Japanese Temple Geometry 126
 Jefferson National Expansion Memo-
 rial 26
 Jerrard, R. P. 43
 Jesuit College of La Flèche 156
 Jesus Christ 18, 22
 Jet Propulsion Laboratory 178
 Johns Hopkins University 171, 178
 Johnson, R. S. 107
 Judaism v, 16
 Jung's Theorem 52
 Jupiter 83
- Kabbalah 10, 16
Kabun 8
 Kakeya Needle Problem 57-58
 Kali (Kalika) 5
 Kelly, L. M. 75
 Kepler Conjecture 155
 Keplerian telescope 155
 Kepler, Johannes 15, 21, 154, 184
 Kepler's Laws 155
 Kepler's solids 155
 Kepler's supernova 155
 Khufu (Cheops) 2, 3
 King David 16
 King Hieron 151
 King Ptolemy 150
 King's College (Cambridge) 171
 King's College (London) 168
 Kirk, Captain 27
 Kline, Morris 153

- Knight's Templar 20
 Knight's Tours 125, 161
 Knuth, Donald Ervin 119-120, 180, 187
 Kochen, S. B. 169
 Koch, Helge von 173, 186
 Koch Snowflake / Anti-Snowflake 58, 173
 Korean Mathematical Olympiad 139
 KRC triangle 24
kriya 5
 Kummer, Ernst 169
kusari 8
- Lagrange, Joseph-Louis 50, 162, 185
 Lagrange multipliers 162
 Lagrange's Equilateral Triangle Solution 83
 Lagrangian function 163
 Lagrangian (L-, libration) points 83
 Lamé, Gabriel 102
 Lamp 112
 Laplace operator 101
 Laplace, Pierre-Simon 161
 Laplacian eigenstructure 101
 Large Hadron Collider 84
 largest
 - circumscribed equilateral triangle 36
 - inscribed rectangle 41
 - inscribed square 41
 - inscribed triangle 52
- Lasker, Emmanuel 172
Last Supper 13, 17, 18
 lateral epicondyle 82
 lattice duality 62
 Latvian Mathematical Olympiad 144
 least-area rotor 56-57
 least-diameter decomposition (open disk) 52
 Lebesgue constant 174
 Lebesgue covering dimension 174
 Lebesgue, Henri 174, 186
 Lebesgue integral 174
 Lebesgue measure 174
 Lebesgue's Dominated Convergence Theorem 174
 Lebesgue spine 174
 Lebesgue-Stieltjes integral 174
 Leech lattice 169
 Legendre, Adrien-Marie 125-126
 Lehmer, D. H. 178
 Leibniz, Gottfried 156, 159-160
 Leonardo of Pisa (Fibonacci) 152, 183
 Leonardo's Symmetry Theorem 154
 Lepenski Vir 1-2
Letters to a Princess of Germany 161
 Leunberger inequality (improved) 53
Liber Abaci (Book of Calculation) 153
 Library of Alexandria 150
 Lifter 84-85
 Likeaglobe Map 97-99
 limiting oxygen concentration (LOC) 86
 Lindgren, Harry 107
 LISA 84
 Liszt, Franz 25
 Lob, H. 66
 lodge (triangular) 197
 logarithmic spiral 70
 London Bridge Station 86
 Los, G. A. 66
 lower explosive limit (LEL) 86
 Loyd, Sam 103, 181, 187
 Lucasian Chair 160
 lunar crater (triangular) 191
 Lux 9
 Luzin, Nikolai 175
- Machine for Questions and Answers* 38

- MacMahon, Percy Alexander 113, 171, 186
- MacMahon's Color Triangles 113, 115-116
- MacTutor History of Mathematics* vi
- magic v, 16
 constant 16
 hexagram 16
 number 16
 star 16
- major third 25
- major triad 25
- Makhuwa 8
- Malfatti circles 66
- Malfatti, Gian Francesco 65, 162, 184
- Malfatti resolvent 162
- Malfatti's Problem 65-66, 162, 166
- Maltese cross 20
- Manchester University 177
- mandorla 22
- Manfredi, Gabriele 162
- mantra 5
- mappings preserving equilateral triangles 75
- marble problem 65
- Marischal College (Aberdeen) 168
- Mars 155
- Marshall, W. 72
- Martin Co., Glenn L. 178
- Marundheeswarar Temple 5
- Masonic Lodges 21
- Masonic Royal Arch Jewel 21
- Mästlin, Michael 155
- Mathemagician 182
- mathematical
 biography v
 competitions v-vi, 129-147
 history v
 properties v, 29-77
 recreations v, 103-128
- Mathematical Association of America 11, 162, 169, 182
- Mathematical Games* 119, 182
- Mathematical Olympiad of
 Moldova 145
 Republic of China 142
- Mathematical Recreations and Essays* 176
- Mathematical Snapshots* 105
- Mathematical Time Exposures* 105
- matrix representation 91-92
- maximum area rectangle 41
- Maxwell-Boltzmann kinetic theory
 of gases 168
- Maxwell color triangle 88, 168
- Maxwell discs 168
- Maxwell distribution 169
- Maxwell, James Clerk 167, 185
- Maxwell materials 169
- Maxwell model (generalized) 169
- Maxwell's demon 169
- Maxwell's equations 168-169
- Maxwell's Theorem 169
- McCartin, Brian J. 102
- McGovern, W. 15
- Mécanique analytique* 163
- Mechanica* 161
- medial epicondyle 82
- medial triangle 54
- Melissen, J. B. M. 44-45
- Mersenne, Marin 156-157, 159
- Mesolithic 1-2
- METAFONT* 180
- method of
 exhaustion 150
 indivisibles 157
- Méthodes nouvelles de la mécanique céleste* 170
- Method of Mechanical Theorems* 151
- Meyer Sound 94
- Middle Ages 22, 121, 152
- midpoint ellipse 51

- Milan Cathedral 18-19
 Millenium Prize Problems 167
 minimum order perfect triangulation
 72
 Minkowski, Hermann 172, 186
 Minkowski plane 75, 173
 Minkowski spacetime 172
 minor triad 25
 Miscellaneous Olympiad Problems 146-
 147
 Mittag-Leffler, Gösta 173
 M-matrices 173
 Möbius band 194
Modern Puzzles 181
 Monad 9
 Monckton, Christopher 125
 Morandi, Maurizio 44
 Morgenstern, Oskar 90
 Morley, Frank 171, 186
 Morley's Theorem v, 35, 171-172
 Morley triangle 35
 Moslems 20
 Most Beautiful Theorems in Math-
 ematics 61
MOTET v-vi
 moth (triangular) 190
 Motzkin, T. 77
 Mozartkugel 100
 Mozart, Wolfgang Amadeus 21, 100
 music v, 25
 musical
 chord 25
 harmony 10
 triangle 192
 Musselman, J. R. 39
 Musselman's Theorem 39

nadis 5
 Nambokucho period 8
 Napoleon's Theorem v, 36-37
 Napoleon triangle 36, 39
 NASA 84
 NASA Echo I 80
 natural equilateral triangles 97-98
 Nazi Party 175
 nearly-equilateral dissections 73
 Nelson, H. L. 107
 neopythagoreans 10
 Neumann boundary condition 102
 neutron star 84
 Neville truss 86
New Mathematical Pastimes 171
 Newton form 160
 Newton's identities 160
 Newton, Sir Isaac 1, 24, 152, 156,
 159-161, 184
 Newton's law of cooling 160
 Newton's Laws 160
 Newton's method 160
 nine-point center 19, 46
 no equilateral triangles on a chess
 board 61
 nonagon (enneagon) 107
 nonattacking rooks 126
 non-Euclidean equilateral triangles
 74
 Nordic Mathematics Competition 144
 North American Network 79-80

 O'Beirne, T. H. 112
 octahedral group 26
 octahedron 11, 15, 97-98, 117
 Odom, George 25-26, 69, 177
 olecranon 82
 olympiad problems vi
*On Finite Sums of Rational Num-
 bers* 178
*On the hypotheses that lie at the foun-
 dations of geometry* 167
*On the number of primes less than
 a given magnitude* 167
 optimal spacing (lunar bases) 111
 optimal wrapping 100
 Order of the Temple 20

- oriented triangles 70
- origami 127
- orthic triangle 54
- orthocenter 39, 46
- Ostrowski, Alexander 173
- Oughtred, William 148
- Our Lord 18
- Oxford University 150

- Pach, J. 55
- Pacioli, Luca 11, 153
- packings v, 44
- Padovan sequence 70
- Padovan spirals 70
- Padovan whorl 70
- pagoda 6-7
- paper folding 127
- palimpsest 151
- Pappus' Centroid Theorem 152
- Pappus' Hexagon Theorem 152
- Pappus of Alexandria 13, 151-152, 183
- Pappus' Problem 152
- parallelogram properties 37
- Parthenon 9
- partition 72-73
- partridge
 - number 72
 - tiling v, 72
- Pascal, Blaise 58, 157, 159, 184
- Pascal's Law of Pressure 159
- Pascal's Mystic Hexagram Theorem 159
- Pascal's Triangle 58-59, 74, 159
- Pascal's Wager 159
- Pauca sed matura* 164
- pedal mapping 54
- pedal triangle 38-39, 54, 118, 127
- Pedersen, Jean J. 117
- Pedoe, Dan 31
- peg solitaire 169
- Pell, John 148
- Pell's equation 157
- Peloponnesian War 149
- pengala* 5
- pentagon 107
- pentagonal dipyramid 15
- Perelman, Grigory 170
- perfect
 - coloring 67
 - tiling 70
 - triangulation 70
- periodic orbit 118-120
- Perplexities* 181
- Pestalozzi, J. H. 165
- Peterhouse, Cambridge 168
- Pfaff, J. F. 164
- Philosophia Sacra* 9
- Picard, Émile 166
- Pinchasi, R. 55
- ping-pong 178
- plaited polyhedra 117
- planar soap bubble clusters 52
- plastic
 - number 70
 - pentagon 70
- Platonic solid 11-13, 117, 150
- Platonic triangles 11
- Platonism 150
- Plato of Athens 11, 149, 183
- Plato's Academy 149-150
- playscape (triangular) 195
- Poincaré-Bendixson Theorem 170
- Poincaré Conjecture 170
- Poincaré disk 75
- Poincaré group 170
- Poincaré, Henri 166, 170, 185
- Poincaré inequality 170
- Poincaré-Linstedt method 170
- Poincaré map 170
- Poincaré metric 170
- Poincaré, Raymond 170
- Polydeuces 83
- polygonal dissections 106-107

- Polygonal Number Theorem 50, 163
 polyhedral formula 11, 156, 161
 polyhedron 11, 13, 15
 Polyominoes 178
 Pompeiu's Theorem 49-50
 Poncelet-Steiner Theorem 165
 Pontormo, Jacopo 17-18
 pool balls (triangular) 192
 pool-ball triangle 117-118
 positively / negatively equilateral triangle 39-40
 Post, K. 43
 Post's Theorem 43
 Potter, Harry 28
Precious Mirror of the Four Elements 59
 Pressman & Co., J. 16
 primary color 86
 Prime Number Theorem 173, 177
Princeps mathematicorum 163
 Princeton University 109, 176-177, 180
 principal frequency 100
Principia Mathematica (Newton) 1, 160-161
Principia Mathematica (Whitehead & Russell) 173
 Principle of Least Action 162
 Principle of the Equilateral Triangle (electrocardiography) 81
 Principle of Virtual Work 163
 Problem of Apollonius 151-152
Problems in the Distribution of Prime Numbers 178
 projective plane 91-92
 Propeller Theorem 64
 Ptolemy 152
 pumpkin (triangular) 193
Puzzles and Curious Problems 181
 pyramid 2-3
 Pythagoras of Samos 149, 183
 Pythagoreans 9, 22, 149
 Pythagorean Theorem 149, 153
 QFL diagram 88-89
 Qianxun Pagoda 6
 Qing Dynasty 6
 quadratrix of Hippias 152
 Quan Fengyou, King 6
 quantum mechanics 102
 Queen Anne 160
 Queen Christina 156
 Queen of the Sciences 164
 quilt (triangular) 194
 Rabbinic Judaism 16
 random point 50
 ranking region 91
 rational triangle 48
 Ravensburger Spieleverlag GmbH 16
 Recreational Mathematics vi, 103, 178, 182
 regular
 heptadecagon 164
 polytope 73-74
 rhombus 61
 simplex 73
 tessellations (planar) 61
 tilings 15, 156
 Renaissance 18, 22
 representation triangle 91
 rep-tiles vi, 112-113, 178
 restricted three-body problem 83
 Resurrection 18
 Resurrection Stone 28
 Reuleaux Triangle 55-56, 96
 Ricatti, Vincenzo 162
 Richmond, H. W. 66
 Riemann, Bernhard 164, 166, 185
 Riemann Hypothesis 167, 173
 Riemannian metric 167
 Riemannian space 167
 Riemann integrability 167
 Riemann-Lebesgue Lemma 174

- Riemann Surfaces 51, 167
 Riemann zeta function 167
 Riordan, Oliver 124-125
Ripley's Believe It or Not 179
 Roberval, G. P. de 159
 Robin boundary condition 102
 Robinson, John 25-26
 Robinson, J. T. R. 96
 rock formation (triangular) 191
 Romanian IMO Selection Test 140
 Romanian Mathematical Olympiad 140
 root movement 25
 Rosicrucian cross 21
 Rosicrucians 21, 156
 Royal Artillery School (Turin) 162
 Royal Institute of Technology (Stockholm) 173
 Royal Military Academy (Woolwich) 171
 Royal Society 105
 Rubik, Ernő 128
 Rubik's Cube 128
 Rudolphine Tables 155
 Russell, Bertrand 1, 169, 173, 186
 Russell's Paradox 173
 Russian Mathematical Olympiad 140
 rusty compass construction 30-31, 153

 Saari, D. G. 91
 Sacred Geometry 22, 69
 sacred paintings 18
 Saint John of the Cross 18
sakthis 5
 Sakuma, Tumugu 8
 salt 9
 Sangaku Geometry 8, 126
 Santa Clara University 117
 Santa Maria delle Grazie 18
 satellite geodesy 79-80
 saturation 88

 Saturn 83
 Saturn's rings 168
 Saviour 18
 Schellbach, K. H. 66
 Schoenberg, I. J. 77, 105
 Schubert, Franz 25
 Schwarz alternating method 169
 Schwarz-Christoffel formula 169
 Schwarz, Hermann Amandus 54, 169, 185
 Schwarzian derivative 169
 Schwarz minimal surface 169
 Schwarz reflection principle / procedure 54, 119, 169
 Schwarz's Lemma 169
Scientific American 119, 178, 181-182
 Scientology v, 24
 Scott, C. 80
 secondary color 86
 Second Punic War 151
 Selberg, Atle 177
 Selby, Alex 124-125
 semiregular tilings 15, 156
 Seversky, A. P. de 84
 Sforza, Ludovico (Duke of Milan) 11
 shawl (triangular) 194
 Sheridan, Captain 27
 Sherlock Holmes 181
 Shield of David 16
 shift register sequences 178
 Shinto 126
 Shiva 5
 shogun 126
 shortest bisecting path 53
 Sicherman, George 117
 siege of Syracuse 151
 Sierpinski carpet 175
 Sierpinski curve 175
 Sierpinski Gasket 58-59, 175
 Sierpinski number 175
 Sierpinski Problem 175

- Sierpinski, Waclaw 174, 186
 Sikorska, J. 75
 Silver Age of Greek Mathematics 152
 similarity transformation 75
 Simmons, G. J. 111
 simplex plot 34
 Sinclair, Commander 27-28
 Singmaster, David 122-123
 six triangles 48-49
 smallest
 enclosing circle 52
 inscribed triangle 54
 small rhombicosidodecahedron 13
 small rhombicuboctahedron 13
 Smith's Prize 168
 Snail 112
 Snefru 2
 Snell's Law 156-157
 snow crystal (triangular) 98
 snub cube 13
 snub dodecahedron 13
 Society of Apostles 168, 173
 Socrates 149
 Socratic dialogues 149
so gusari 8
 Soma cube 179
 Son 18
 Sorbonne 174
 Southern Illinois University 176
Spaceship Earth 176
 space-time continuum 172
 Special Theory of Relativity 172
 spherical equilateral triangles 74
 Sphinx 112
 spidrons vi, 127-128
 Square and Triangle Puzzle 105-106
 square hole drill vi, 95-96
 stamp (triangular) 192
 Stanford University 180
 Star of David 16
Star Trek 27
 Steiner ellipses 166
 Steiner, Jakob 66, 165, 167, 175, 185
 Steiner surface 165
 Steiner Theorem 165
 Steiner triple-system 91, 166
 Steinhaus, Hugo 43, 105
 Stephen the Clerk 150
 Stern-Halma 16
 Stertenbrink, Günter 124-125
 St. John's College, Cambridge 168
 Stockholm University 173
 Stone Age 2
 Stone, Arthur H. 109
 stone (triangular) 191
 St. Petersburg Academy of Sciences
 161
Strand Magazine 181
 Straus, E. G. 111
 street signs (triangular) 196
 strictly convex position 55
 Sun 83-84
 superconducting (Sierpinski) gasket
 vi, 94-95
Supper at Emmaus 17, 18
Supreme Fascist 177
 surreal numbers 179-180
sushumna 5
 Suzuki, Fukuzo 8
 sweets (triangular) 193
Symbolic Logic 169
 symmetry
 group 25, 66
 tiling 67
Synagoge (Collection) 152
Synergetics 176
 syzygies 42-43
 Szostok, T. 75
 Tahiti Triangle 190
 Tang Dynasty 6
Tangencies 151
 tantra 5
 Tarot 10

- Tartaglian Measuring Puzzles 120-121
tattvas 5
 Tatzenkreuz 20
 Technical University of Berlin 169
 Technical University of Braunschweig 125
 Technische Hochschule (Graz) 175
 telegraph 164
 Telesto 83
 Tenebrae 9
 Tercentenary Euler Celebration 162
 ternary diagram 33-34, 88, 90, 121
 Terra 9
 tertiary color 86
 tessellations to fractals 62-63
 Tethys 83
 tetraicaicadeltahedron 15
 Tetragrammaton 10
 tetrahedral geodesics 64-65
 tetrahedron 9, 11, 15, 117
 tetraktys 9-10
Tetris 178
TeX 180
 Thales 149
 Theaetetus 149-150
 Theobald, Gavin 107
 Theodorus 149
Theorema Egregium 164
Theoria motus corporum coelestium 164
 Theory of Forms 149-150
 Thirty Years' War 156
 three-body problem 83, 163
 three jug problem 120-121, 154
 Three Pagodas 6-7
 Thurston model 75
Timaeus 11, 150
 Torricelli, Evangelista 35, 157-158, 184
 Torricelli's Equation 158
 Torricelli's Law / Theorem 158
 Torricelli's Trumpet (Gabriel's Horn) 158
 torsional rigidity 100
 Traffic Jam Game 123
Traité du triangle arithmétique 58, 159
Trattato della Pittura 153
Trattato generale di numeri e misure 154
 Travolta, John 24
Treatise on Electricity and Magnetism 168-169
 triangle 9
 Triangle and Square Puzzle 105
Triangle Book 180
 triangle geometry v
 Triangle Inequality 52
 triangle in rectangle 41
 triangle in square 41-42
 triangles with integer sides 122-123
 Triangle-to-Triangle Dissection 106
 Triangle Waist Co. 198
 triangular
 bounds 100-101
 dipyramid 15
 honeycomb 125-126
 numbers 10, 32-33, 59
 triangulation triangles 38-39
 trihexaflexagon 108-109
 trilinear coordinates 33
 Triluminary 27-28
 Trinity 4, 18
 Trinity College, Cambridge 160, 173
 Tripurasundari 5
 trisection thru bisection 32
 Trojan asteroid 83
 truncated
 cube 13
 dodecahedron 13
 octahedron 13
 tetrahedron 13
 Tschirnhaus, E. W. von 159

- Tuckerman, Bryant 109
 Tukey, John W. 109
 tulip (triangular) 189
 Turkish Mathematical Olympiad 141
 Tutte, W. T. 70
 Tweedie, M. C. K. 120
 two-color map 110
- UFO (triangular) 190
 Uhura, Lieutenant 27
 Ulam, Stanislaw 177
 Umble, R. 120
 University of Alaska 178
 University of Basel 161
 University of Berlin 165-166, 169
 University of Bonn 172, 175
 University of Breifswald 175
 University of Caen 170
 University of California-Berkeley 94, 178
 University of California-San Diego 179
 University of Chicago 178, 182
 University of Ferrara 162
 University of Göttingen 164, 166, 169, 172, 175
 University of Halle 169
 University of Hamburg 175
 University of Helmstedt 164
 University of Königsberg 172, 175
 University of Lvov 175
 University of Orleans 157
 University of Paris 170
 University of Pisa 175
 University of Poitiers 156
 University of Prague 175
 University of Southern California 178
 University of Toronto 176
 University of Tübingen 155, 175
 University of Vienna 175
 University of Warsaw 175
 upper explosive limit (UEL) 86
- USA Mathematical Olympiad 129, 136-137
 U. S. Chess Hall of Fame 181
 U. S. Coast and Geodetic Survey 80
 USDA Soil Texture Triangle 88-89
- Valen 27-28
 Van der Waerden, B. L. 15
 ventricular hypertrophy 81
vesica piscis 22
 vibration theory 102
 Victoria cross 20
 da Vinci, Leonardo 11, 13, 17-18, 153, 183
 Virgin Mary 22
 viruses 99
 Vishnavite 16
 Vishnu 5, 16
 Vitruvius 18
 Viviani's Theorem 33-34
 Viviani, Vincenzo 157-158, 184
 Viviani Window 159
 Von Neumann, John 90
 Voronoi diagram 62
 Voronoi, G. F. 175
 voting
 paradox 91
 theory vi, 91
 Voyager spacecrafts 168
- Wackhenfels, Baron von 155
 Wagner, Richard 25
 Wagner, Rudolf 165
 Wainwright, R. T. 71
 Wallenstein, General 155
 Wallis, John 76, 148
Wanderer Fantasy 25
 Wankel engine 96
 Warren truss 85-86
Wasan 7
 Washington, George 21
 Watts drill 96

Weber, Wilhelm 164
Weierstrass, Karl 169
Weisstein, E. W. 30
Weizmann Institute of Science 123
Wetzel, J. E. 41, 43
whorled equilateral triangle 69
Widder, D. V. 178
Wikipedia, The Free Encyclopedia vi
Wiles, Andrew 157
Wilson's Theorem 163
wing (triangular) 190
Winter, Edgar 24
Winter Triangle 190
Wirtinger, Wilhelm 175
World Chess Champion 172
World War I 175
World War II 175, 182
Wrangler (Tripos) 168
wrapping chocolates vi

yantra 5, 16

Zalgaller, V. A. 66
Zanotti, Francesco Maria 162
Zaremba, S. 175
Zathras 27
zeta function 161
Ziegler's Giant Bar 180
Zionism 16